



HITCH INSTALLATION INSTRUCTIONS

MAKE: BMW
YEARS: 2007 - 2013
MODEL/TRIM: 3 Series Convertible
 3 Series Coupe

www.stealthhitches.com 833-694-4824

RACK RECEIVER KIT#: **SHR31004**

COMPATIBLE WITH TOW KIT: **SHT25002**

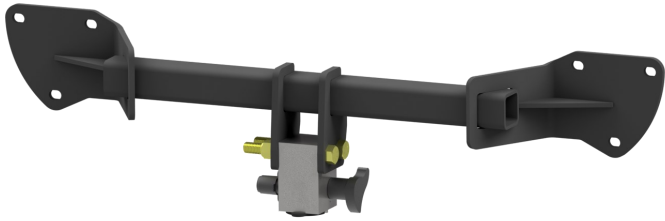

2" RACK RECEIVER MAXIMUM PAYLOAD: 350 LBS
MAXIMUM TOW RATING: 3500 LBS
MAXIMUM TONGUE WEIGHT: 350 LBS

UNDER VEHICLE TRIMMING:

HEAT SHIELD: **NO**
 FASCIA: **NO**
 GRAVEL GUARD TRIMMING: **YES**
 (SOME MODELS)



READ ALL INSTRUCTION WARNINGS AND LABELS



NO WELDING, METAL DRILLING OR VISIBLE TRIMMING REQUIRED

PARTS SUPPLIED WITH RACK RECEIVER KIT:

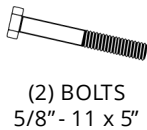

PARTS USED FOR **DUAL** EXHAUST ONLY:



ADDITIONAL PARTS FOR TOW KIT:



TOOLS REQUIRED:

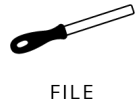
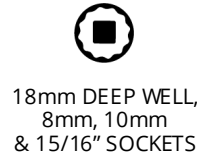

ADDITIONAL TOOLS FOR TOW KIT:



<THESE INSTRUCTIONS MUST BE GIVEN TO THE END USER>

NOTICE: Installation of Stealth products may or may not require the addition of a wiring harness to the vehicle.

- The Rack Receiver only product does not require adding a wiring harness.
- The Rack Receiver plus Tow Kit requires the addition of a "Passive" wiring harness to the vehicle. The passive harness "reads" the output of the vehicle's lights and translates the signals to the trailer without being connected to the vehicle computer.

INSTALLATION NOTE: In most instances, these instructions will only outline disassembly of vehicle components. Re-installation of components will require the installer to retain vehicle hardware and work through disassembly instructions in reverse order. When installation is complete, double check that all vehicle components have been replaced and are secured.

IMPORTANT SAFETY NOTICE FOR STEALTH HITCH INSTALLERS AND CUSTOMERS.

Read all installation and operating instructions along with all labels before installing or using this product. Do not perform any installation or towing procedures without fully understanding the correct tools and actions for all steps. Call for support if needed.

⚠ WARNING Failure to comply with the safety information in these instructions could result in serious injury or death.

- ⚠ Do not modify this product in any manner. Doing so could alter its integrity and lead to a loss of attachment between the trailer and the tow vehicle.
- ⚠ Adding Stealth hitch components to the chassis of any vehicle can be hazardous. There is potential for unexpected combustion of fuel, electric shock, burns, shifting or falling of unstable vehicle, damage to vehicle, injury from tool usage and many other hazards. This installation must be completed by someone who is aware of the hazards involved. This person must be knowledgeable of proper safety procedures for a vehicle modification of this nature, and for usage of the equipment required to perform the installation.
- ⚠ Without proper knowledge, towing can be a dangerous activity. Understand all the risks involved with towing before proceeding. For information on towing safety, see "**The Trailer Handbook: A Guide to Understanding Trailer and Towing Safety**" from the National Association of Trailer Manufacturers, www.NATM.com and your trailer and tow vehicle manufacturer's owner's manual.
- ⚠ Do not exceed tow or tongue rating of coupler, tow or tongue rating of hitch, or tow or weight ratings of tow vehicle or trailer. See vehicle and trailer manufacturer information for ratings. Exceeding these ratings may cause damage to towing components or loss of attachment between the trailer and vehicle.
- ⚠ While installation is being performed, check for signs of damage or excessive corrosion. Do not install hitch components over vehicle parts that are broken or have compromised structural integrity.
- ⚠ This product was designed to fit vehicles in their original, "as manufactured" condition. Compatibility with vehicles having replacement parts, or other modifications is not guaranteed. Inspect vehicle for modifications before installation of this product.
- ⚠ Some accessories, like the rack receiver, are not rated for towing. Do not use any accessories without proper knowledge of their use.
- ⚠ A visual inspection of the hitch should be performed before each use. Regularly check that all connections are secure, including those that secure the hitch to the vehicle. Check for cracks or damage to the hitch. Do not use the hitch if cracks or damage outside of normal wear is found. Using a hitch that has unsecure connections and/or cracks or damage could result in damage to the tow vehicle, trailer, towing components and loss of attachment between the tow vehicle and trailer.
- ⚠ Stealth hitches are not compatible with any weight distribution or sway control products. Adding additional products to the trailer or chassis which modifies the function of the Stealth hitch may cause hitch failure.

NOTICE: Installation of hitch requires removal of vehicle parts and interaction with vehicular electronics. Before installation, check the condition of body panels and note any locations where panels are not flush. Check the electronic functions of the vehicle, such as: headlights, taillights, turn signals, cameras, backup sensors, Parking Distance Controller (PDC), foot activated cargo access, etc. It is the responsibility of the installer to restore the fit and function of the vehicle

GAIN ACCESS TO MOUNTING AREA



1. Open the vehicle cargo area. Remove the driver and passenger side CORNER panels by turning the knob 90°.

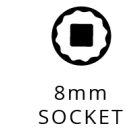
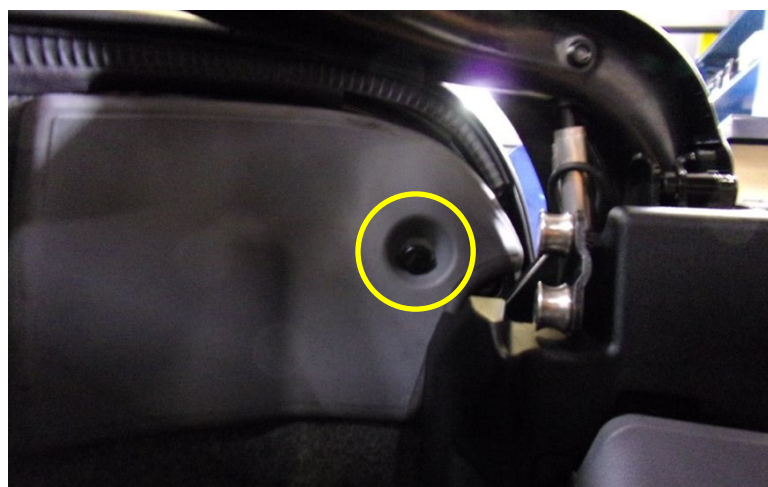

2. Locate and remove (3) nuts securing the taillights. Disconnect light connector. Slide taillight rearward to remove.



3. Locate and remove a plastic cover on each side of the hatch with a 90 degree pick tool. Remove screw that was exposed with Torx.



GAIN ACCESS TO MOUNTING AREA CONTINUED



8mm
SOCKET



T25 TORX

4. Inside the rear wheel well, behind the tire, locate the (3) screws which are holding the wheel well liner (yellow arrows). Remove these screws and move the liner back toward the tire. Behind the liner locate (1) additional screw and remove it (green arrow).



10mm
SOCKET



8mm
SOCKET

5. Under the rear of the vehicle, remove (10) screws from the bottom of the fascia. Remove (4) screws from the gravel guard.

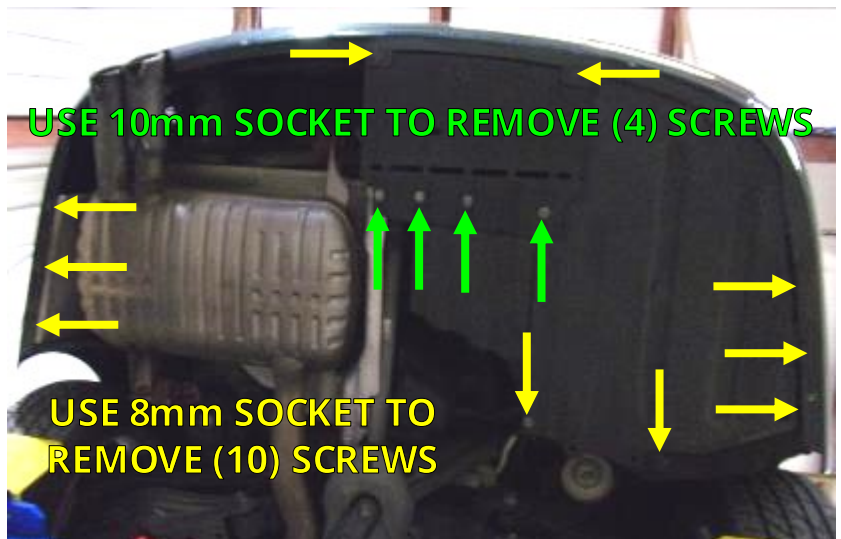

PLASTIC
PRY TOOLS

6. The rear fascia is clipped to the vehicle body above and behind the wheel wells. Pull outward on the top front of the rear fascia to expose a clip in the seam. With a plastic pry tool, push down on the exposed clip to disconnect. Continue to pull outward and rearward on the fascia and disconnect clips as they are exposed until all clips are disconnected. Repeat on other side of vehicle.



GAIN ACCESS TO MOUNTING AREA CONTINUED



90 DEGREE PICK

7. This step requires a partner. Pull the fascia rearward enough to access the (4) PDC sensor plugs inside the fascia. Press down on the clips to unplug the PDC sensor plugs, if present. In some cases a 90 degree pick tool will be needed to disconnect the sensor plugs. Remove the fascia completely.

NOTICE: Carefully remove the fascia and place on a blanket or pad.

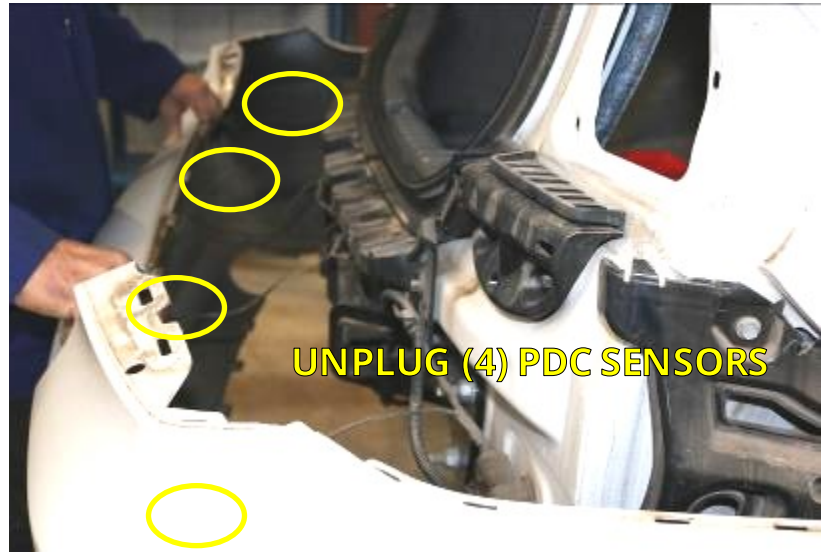

18mm DEEP WELL SOCKET

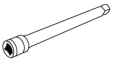

SOCKET EXTENSION

8. Remove (6) nuts that secure the factory reinforcement beam with a socket. Save the nuts for hitch installation. Discard the factory reinforcement beam.

NOTE: The dual exhaust models will have (2) rubber hangers attached to the factory beam. Disconnect the hangers before removing the beam.

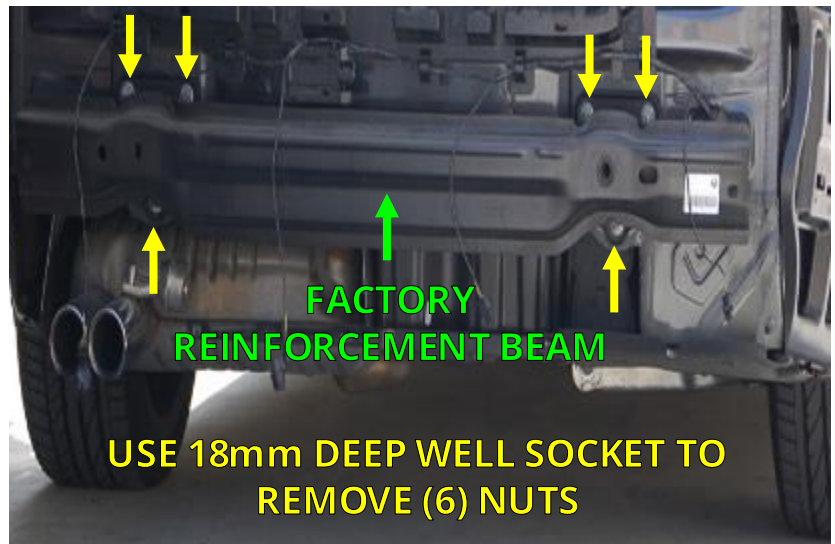

INSTALL STEALTH HITCH FRAME



18mm DEEP WELL SOCKET



TORQUE WRENCH

9. **If vehicle has a single exhaust:** Install the Stealth hitch frame onto the vehicle studs. Center the hitch frame. Use a torque wrench to tighten the factory nuts to 85 ft.-lbs.

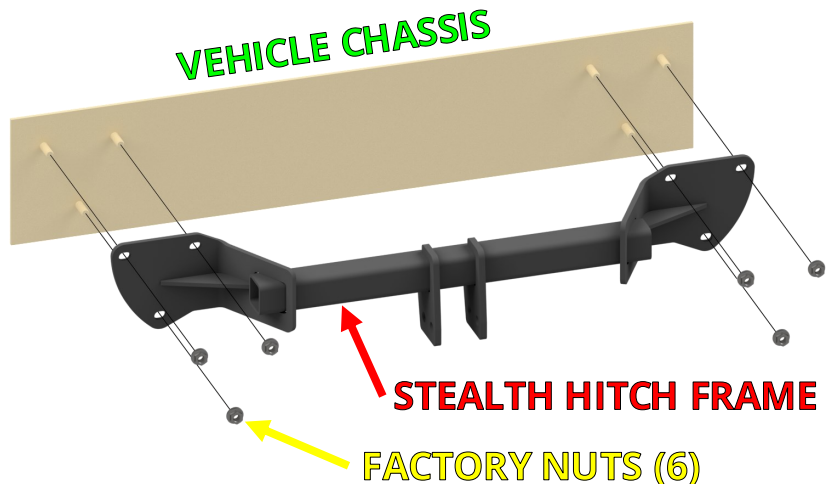

INSTALL STEALTH HITCH FRAME CONTINUED



18mm
DEEP WELL
SOCKET



TORQUE
WRENCH



PHILLIPS HEAD
SCREWDRIVER

If vehicle has a dual exhaust:

Install the Stealth hitch frame onto the vehicle studs. Place each exhaust bracket on the lower mounting stud so that the "hangers" point towards the center of the vehicle as shown in the image. Use the (6) factory nuts to secure the hitch and exhaust brackets. Center the hitch frame. Use a torque wrench to tighten the factory nuts to 85 ft.-lbs. Attach rubber exhaust hangers onto exhaust brackets.

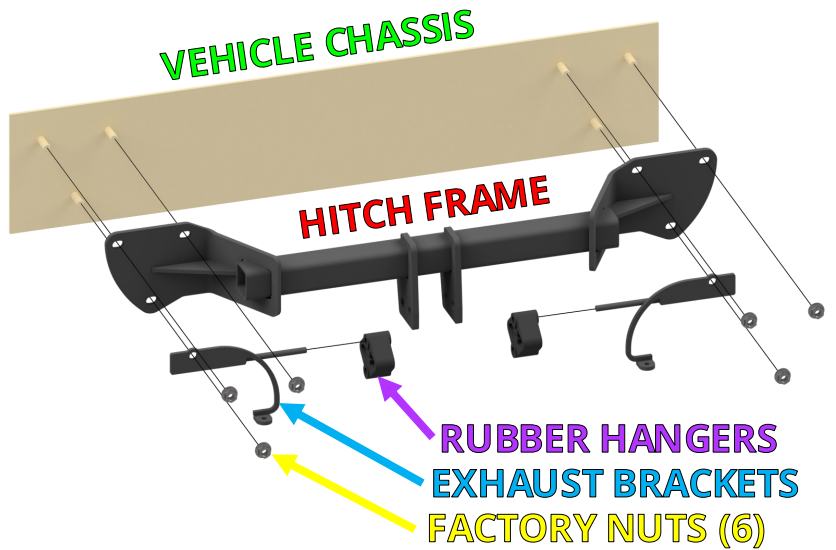

MOUNT LATCH BLOCK



15/16"
SOCKET



15/16" OPEN
END WRENCH



TORQUE
WRENCH

11. Installation of the latch block varies depending on which kit you are installing.

- **Rack Receiver Kit:** Install the latch block with (2) 5/8"-11 x 5" bolts and (2) 5/8" nylock nuts. Tighten each bolt to 150 ft.-lbs.
- **Tow Kit:** Install the latch block and (2) chain hooks with (2) 5/8"-11 x 5" bolts and (2) 5/8" nylock nuts. Tighten each bolt to 150 ft.-lbs.

NOTICE: Keys are packaged within the latch block, remove keys and store in safe location.

RACK RECEIVER KIT INSTALL



TOW KIT INSTALL

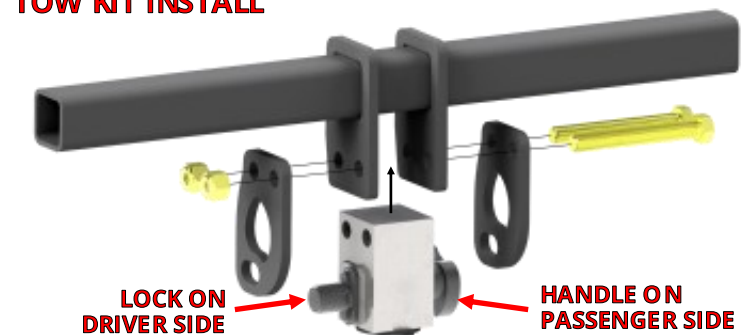

**IF INSTALLING A RACK RECEIVER KIT, SKIP TO STEP 24.
IF INSTALLING A TOW KIT, CONTINUE TO STEP 12.**

INSTALL PASSIVE WIRING KIT

#	DESCRIPTION	QTY
1	4-WAY CONNECTOR HARNESS	1
2	CONTROL MODULE	1
3	4-WAY CONNECTOR COVER	1
4	CABLE TIE - 8"	4
5	CABLE TIE - 14"	2
6	MAGNETIC CABLE HOLDER	1
7	M8 SERRATED FLANGE NUT	1
8	FORK TERMINAL	1
9	ADHESIVE FOAM STRIP	2
10	BUTT CONNECTOR (RED)	4
11	CLAMP-ON CONNECTORS	4

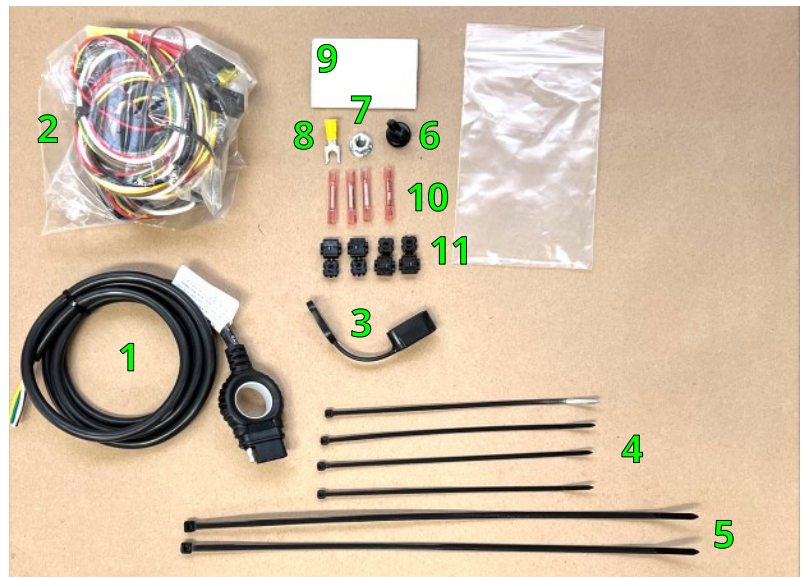

12. Locate the wiring kit box. Review the contents of the box against the list above to check for missing components. The passive wiring kit uses a control module to manage the functions of the trailer lighting. The module has an **"input"** side that receives power from the vehicle's battery and signals from the vehicle's taillights. The **"output"** side of the module delivers this information to the 4-way plug. The control module is connected to the vehicle's battery and taillight wiring as outlined in the next steps.

NOTICE: Do not allow electrical system to become disconnected from power or ground. Doing so may interrupt electrical systems!

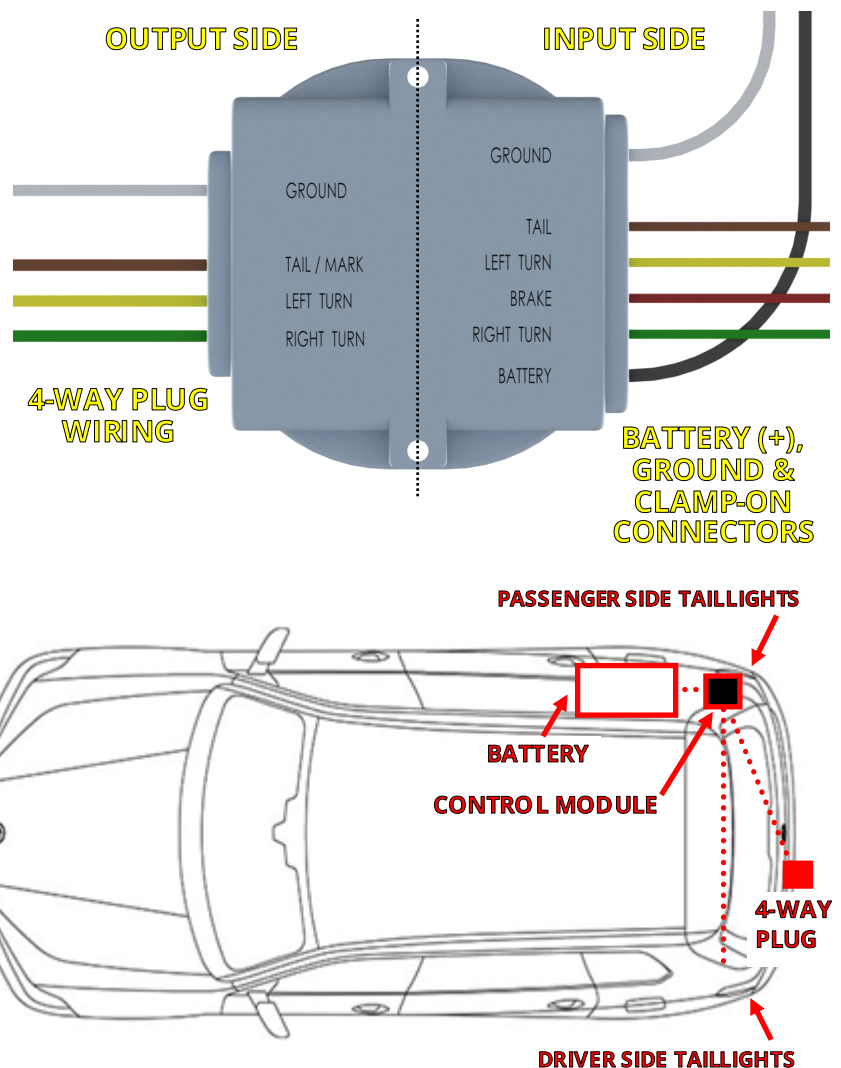

INSTALL WIRING KIT CONTINUED



DRILL &
3/8" BIT

13. Locate wiring harness grommet on the passenger side of the vehicle. Drill a 3/8" hole in the grommet for wiring harness. Make sure to drill through grommet only and not to damage harness.

NOTICE: Confirm that there is nothing inside vehicle behind grommet that can be damaged.

14. Retrieve the 4-way connector harness from the wiring kit box. Route the 4-way plug wires through hole drilled in grommet from outside of the vehicle to the inside of the vehicle.

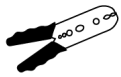

STRIPPER/
CRIMPING
TOOL

18. On the passenger side of the vehicle, place the wiring harness control module in the cargo compartment area. Locate the tail of the 4-way connector wire and the output side wires of the control module. Attach each similar color wire to each other using a red butt connector and crimping tool.

NOTICE (OPTIONAL): The butt splice connectors are heat shrink connectors. Apply heat to waterproof the connectors after crimping.

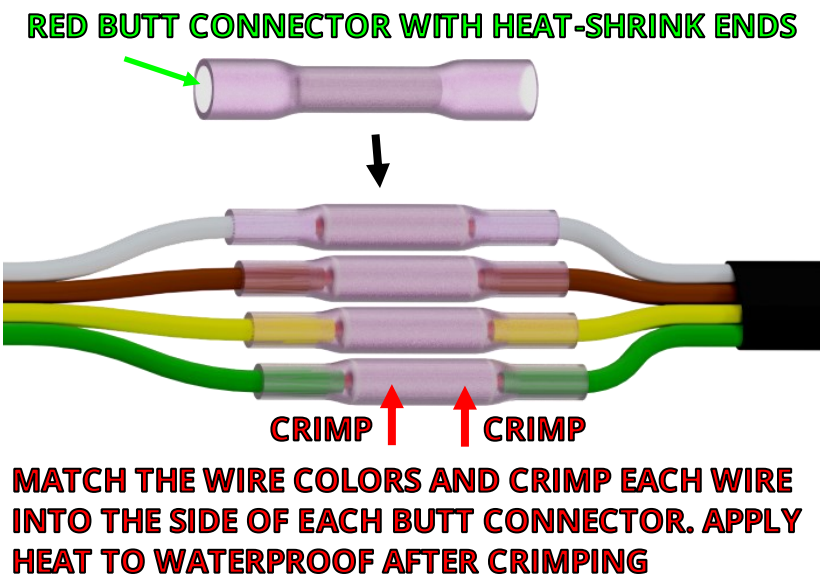

16. Secure harness to Stealth hitch frame with cable ties. Maintain an 18" loop from the cable tie to the 4-way plug. Add the magnetic cable holder and secure to the harness close to the 4-way plug, with a cable tie.

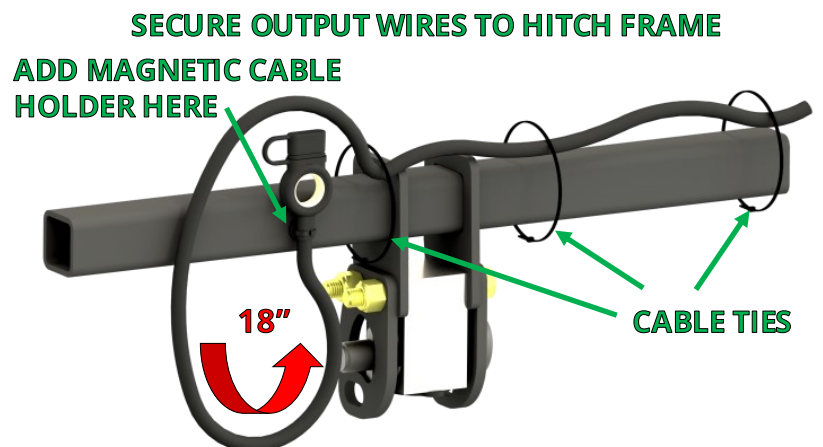

INSTALL WIRING KIT CONTINUED



PLIERS



MULTIMETER

17. The wires on the input side of the module need to be attached to the vehicle wiring. Inside the passenger side vehicle compartment locate the indicated part of the vehicle wiring harness. The wire loom may need to be removed. Use clamp-on connectors to connect the brown, green, and red wires to vehicle wiring harness. (As shown in reference table below.)



NOTE: Vehicles may have different wire colors than those shown. Verify circuits (wire colors) with multimeter.



PLIERS







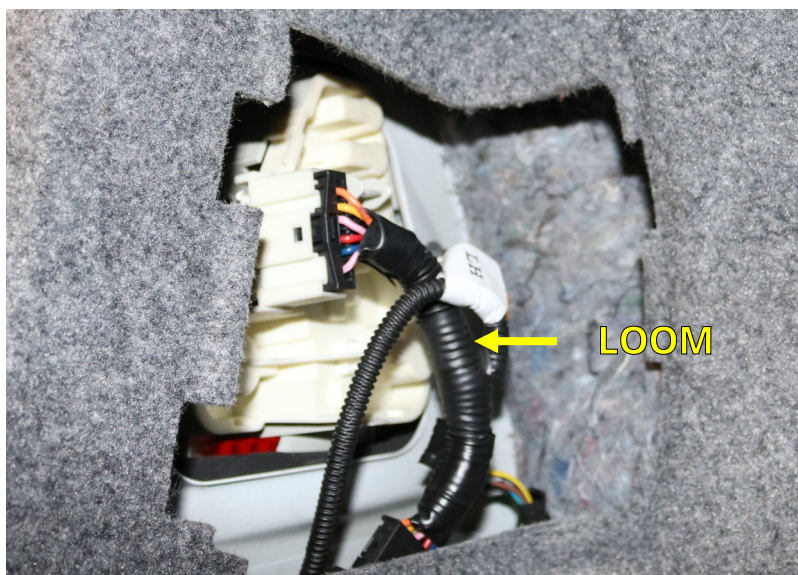





MULTIMETER

18. Using an existing vehicle wire harness as a guide, route the yellow input wire to the driver side of the vehicle. The threshold at the bottom of the trunk opening may need to be removed. Remove enough of the driver side wire loom to gain access to taillight wiring. Use a clamp-on connector to connect the yellow wire to left turn signal wire behind the taillight. (As shown in reference table below.)



CLAMP-ON CONNECTOR COLOR REFERENCE TABLE

SIGNAL INPUT WIRES			POWER & GROUND WIRES		
FUNCTION	HARNESS	VEHICLE			
LEFT TURN	 YELLOW	 BLACK/WHITE	12V+ (POWER)	 BLACK	BATTERY (+)
RIGHT TURN	 GREEN	 BLUE/GRAY	GROUND	 WHITE	BATTERY (-)
MARKER	 BROWN	 GRAY/PURPLE	NOTICE: Do not connect the red brake wire. This vehicle does not utilize a separate brake circuit. The brake signal is sent down the left and right turn circuits simultaneously.		
BRAKE	 RED	 BLACK/YELLOW			

NOTE: If two colors are listed, the first color is the dominant color.

INSTALL WIRING KIT CONTINUED



10mm
SOCKET

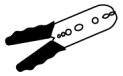

STRIPPER/
CRIMPING
TOOL

19. Uncover the battery. Trim white ground wire so it will reach the negative battery terminal (-) without excess wire. Crimp supplied fork terminal to the ground wire with a crimping tool. Connect the ground wire to the negative battery terminal (-).

NOTICE: Loosen battery terminals just enough to install wiring, so vehicle wiring does not lose ground or power.

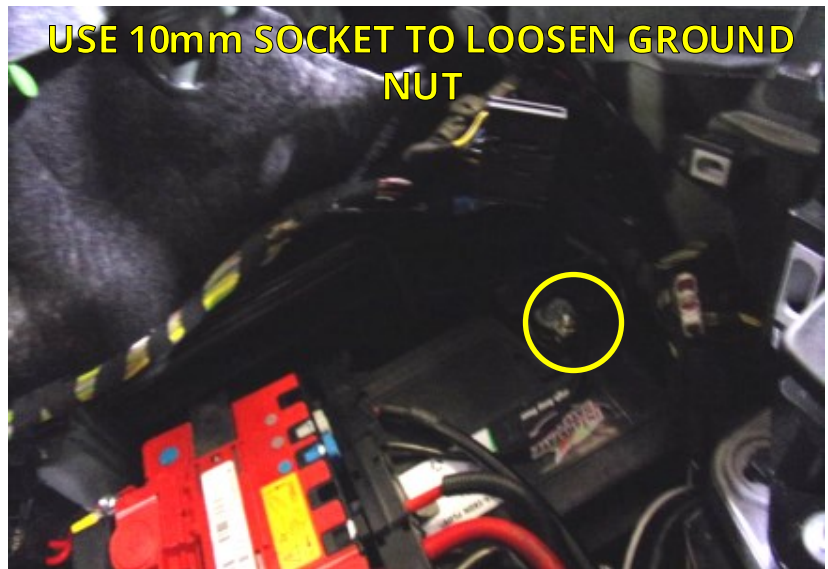

10mm
SOCKET

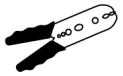

STRIPPER/
CRIMPING
TOOL

20. Locate the fuse holder supplied in the wiring kit box. Remove the fuse from fuse holder. Trim black power wire so it will reach the positive battery terminal (+) without excess. Crimp fuse holder lead to power wire. Connect fuse ring terminal to the positive battery terminal (+).

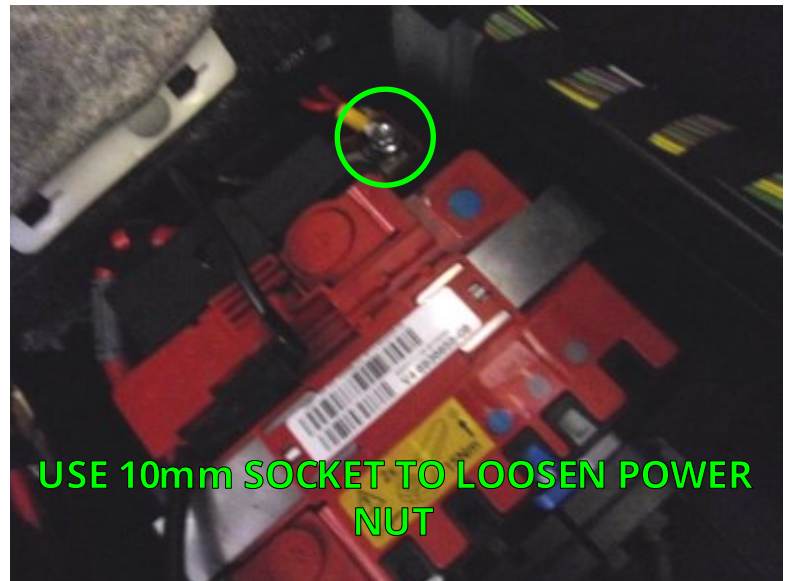

SILICONE

21. Reinstall the 20 Amp fuse in the fuse holder. Test the 4-way plug using a multimeter or connect the plug to a trailer and verify that the lights and brakes work correctly.

NOTE: Taillights will need to be temporarily plugged in during testing.

22. Use the provided adhesive foam strips to secure the control module to an inside body panel. Use silicone to waterproof the grommet.
23. Secure all wires and wiring components. Use the remaining cable ties to secure wiring so that it is not loose and will not interfere with replacement of the fascia. Wiring should not be visible once the vehicle is reassembled.

CUT ACCESS TO LATCH BLOCK



DREMEL TOOL



FILE

24. Cut out gravel guard with Dremel tool. Use a file to smooth out the cut.

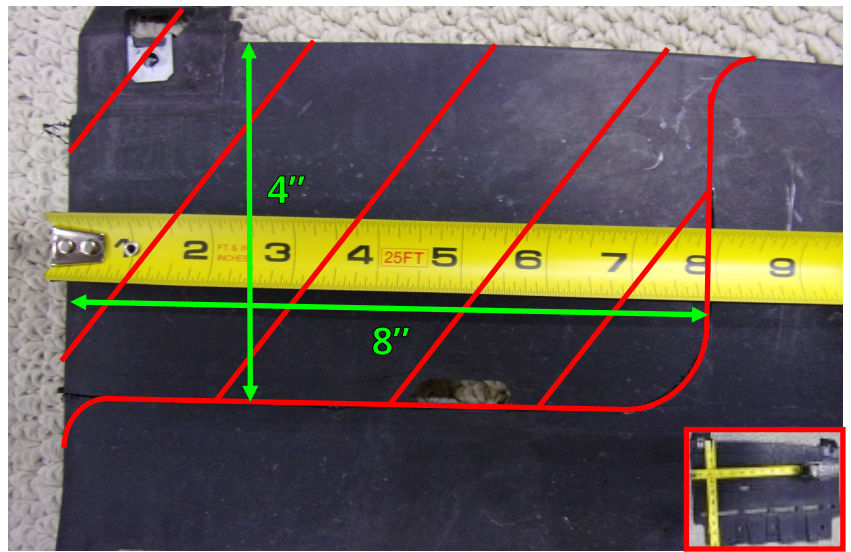

REINSTALL VEHICLE COMPONENTS

25. Reattach and secure the fascia, taillights, and other vehicle components in reverse order. Refer to Steps 1-7.

NOTICE: Remember to plug in the (4) sensor plugs in Step 7 before reinstalling the fascia.

- **If vehicle has a dual exhaust:** Use the supplied 1/4" screws, washers, and serrated flange nuts to secure the bottom ends of the fascia to the exhaust brackets for support.



FINAL VEHICLE EXAMINATION

26. Examine the body panels to ensure that they are in a pre-installation condition. Test the electronic functions of the vehicle. Correct any inconsistencies.
27. Ensure that hitch components work properly.
 - **Verify that the lock works correctly.** Push in the safety lock on the latch block then unlock with key. The lock should slide back out with the key when unlocked.
 - **Verify that each accessory can be installed correctly.** Use the following steps to install and remove each accessory that will be used with the hitch. (*Rack Receiver* and *Ball Mount* if purchased.)
 1. Prepare latching mechanism. Turn handle clockwise if needed.
 2. Firmly insert "post" of accessory into latch block until handle releases indicating that the accessory is latched.
 3. Push in the safety locking pin until it fully engages. The locking pin prevents the handle from turning when pushed in, and confirms that the block is securely latched onto the accessory. The safety locking pin will not depress if the accessory is not fully latched.
 4. Use key to release safety locking pin.
 5. While holding on to the accessory, rotate handle clockwise to release and remove the accessory.
 - **Verify that no part of the accessories come into contact with the body of the vehicle.**

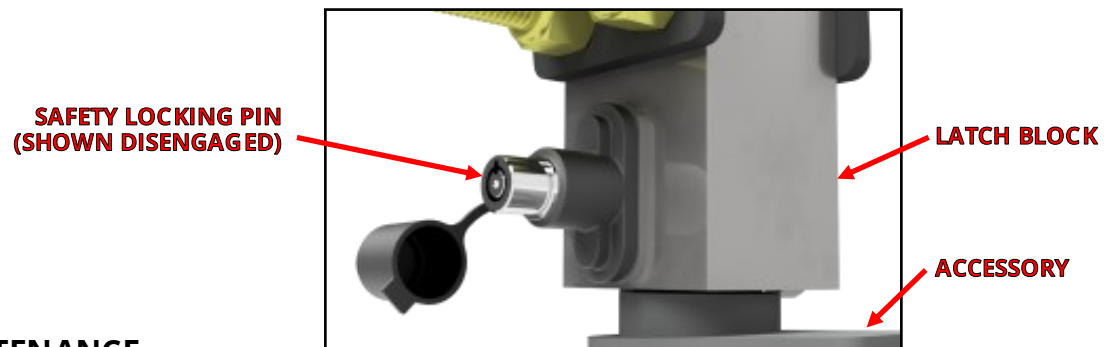

PRODUCT USE AND MAINTENANCE

NOTICE: If the hitch is being installed by a professional, the installer is responsible for training the end user in the use and maintenance of the product.

- **Accessory installation procedure:**
 1. Prepare latching mechanism. Turn handle clockwise if needed.
 2. Firmly insert "post" of accessory into latch block until handle spins counter-clockwise indicating that the accessory is latched.
 3. Always depress the safety locking pin and check that it has fully engaged.
- **Never use any accessory with the safety lock disengaged.** Until the safety locking pin is engaged, the handle is able to turn. A fully engaged safety locking pin is confirmation that the accessory is properly latched into the latch block.
- **Never use the rack receiver for towing.** The rack receiver accessory is only to be used with payload carrying products, such as bike racks or luggage racks.
- **Before each use, give the post of the accessory a light coating of lithium based grease.**
- **Before each use, inspect the hitch to ensure that all bolted connections are secure and that no cracks or damage are present.** Do not tow with the hitch if cracks or damage outside of normal wear is found.
- **Remove the Stealth accessories from the latch block after each use.** Do not leave accessories plugged in for extended periods of time.