



www.stealthhitches.com 833-694-4824

HITCH INSTALLATION INSTRUCTIONS

MAKE: AUDI **YEARS:** 2018 - 2023 **MODEL/TRIM:** Q5 / SQ5
 2021 - 2023 Q5 Plug-in Hybrid (rack only)
 NOTE: Tow kit is not compatible with Q5 Plug-in Hybrid vehicles

RACK RECEIVER KIT#: **SHR30014**

COMPATIBLE WITH TOW KIT: **SHT25033**



2" RACK RECEIVER MAXIMUM PAYLOAD: 600 LBS
MAXIMUM TOW RATING: 6000 LBS
MAXIMUM TONGUE WEIGHT: 600 LBS

UNDER VEHICLE TRIMMING:

HEAT SHIELD: **NO**
 FASCIA: **NO**
 GRAVEL GUARD TRIMMING: **NO**



READ ALL INSTRUCTION WARNINGS AND LABELS



NO WELDING, METAL DRILLING OR VISIBLE TRIMMING REQUIRED

PARTS SUPPLIED WITH RACK RECEIVER KIT:

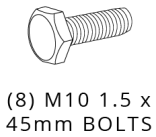
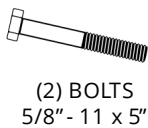

TOOLS REQUIRED:

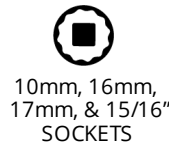

ADDITIONAL PARTS FOR TOW KIT:



ADDITIONAL TOOLS FOR TOW KIT:



RACK RECEIVER INSTALLATION: USE STEPS 1-19, & 34-37
TOW KIT INSTALLATION: USE STEPS 1-37

<THESE INSTRUCTIONS MUST BE GIVEN TO THE END USER>

NOTICE: Installation of Stealth products may or may not require the addition of a wiring harness to the vehicle.

- The Rack Receiver only product does not require adding a wiring harness.
- The Rack Receiver plus Tow Kit requires the addition of a "Passive" wiring harness to the vehicle. The passive harness "reads" the output of the vehicle's lights and translates the signals to the trailer without being connected to the vehicle computer.

INSTALLATION NOTE: In most instances, these instructions will only outline disassembly of vehicle components. Re-installation of components will require the installer to retain vehicle hardware and work through disassembly instructions in reverse order. When installation is complete, double check that all vehicle components have been replaced and are secured.

IMPORTANT SAFETY NOTICE FOR STEALTH HITCH INSTALLERS AND CUSTOMERS.

Read all installation and operating instructions along with all labels before installing or using this product. Do not perform any installation or towing procedures without fully understanding the correct tools and actions for all steps. Call for support if needed.

⚠ WARNING Failure to comply with the safety information in these instructions could result in serious injury or death.

- ⚠ Do not modify this product in any manner. Doing so could alter its integrity and lead to a loss of attachment between the trailer and the tow vehicle.
- ⚠ Adding Stealth hitch components to the chassis of any vehicle can be hazardous. There is potential for unexpected combustion of fuel, electric shock, burns, shifting or falling of unstable vehicle, damage to vehicle, injury from tool usage and many other hazards. This installation must be completed by someone who is aware of the hazards involved. This person must be knowledgeable of proper safety procedures for a vehicle modification of this nature, and for usage of the equipment required to perform the installation.
- ⚠ Without proper knowledge, towing can be a dangerous activity. Understand all the risks involved with towing before proceeding. For information on towing safety, see "**The Trailer Handbook: A Guide to Understanding Trailer and Towing Safety**" from the National Association of Trailer Manufacturers, www.NATM.com and your trailer and tow vehicle manufacturer's owner's manual.
- ⚠ Do not exceed tow or tongue rating of coupler, tow or tongue rating of hitch, or tow or weight ratings of tow vehicle or trailer. See vehicle and trailer manufacturer information for ratings. Exceeding these ratings may cause damage to towing components or loss of attachment between the trailer and vehicle.
- ⚠ While installation is being performed, check for signs of damage or excessive corrosion. Do not install hitch components over vehicle parts that are broken or have compromised structural integrity.
- ⚠ This product was designed to fit vehicles in their original, "as manufactured" condition. Compatibility with vehicles having replacement parts, or other modifications is not guaranteed. Inspect vehicle for modifications before installation of this product.
- ⚠ Some accessories, like the rack receiver, are not rated for towing. Do not use any accessories without proper knowledge of their use.
- ⚠ A visual inspection of the hitch should be performed before each use. Regularly check that all connections are secure, including those that secure the hitch to the vehicle. Check for cracks or damage to the hitch. Do not use the hitch if cracks or damage outside of normal wear is found. Using a hitch that has unsecure connections and/or cracks or damage could result in damage to the tow vehicle, trailer, towing components and loss of attachment between the tow vehicle and trailer.
- ⚠ Stealth hitches are not compatible with any weight distribution or sway control products. Adding additional products to the trailer or chassis which modifies the function of the Stealth hitch may cause hitch failure.

NOTICE: Installation of hitch requires removal of vehicle parts and interaction with vehicular electronics. Before installation, check the condition of body panels and note any locations where panels are not flush. Check the electronic functions of the vehicle, such as: headlights, taillights, turn signals, cameras, backup sensors, Parking Distance Controller (PDC), foot activated cargo access, etc. It is the responsibility of the installer to restore the fit and function of the vehicle.

GAIN ACCESS TO MOUNTING AREA



T20 TORX

1. Open the rear hatch, locate and remove (2) plastic screws on the bottom left and right corners under the rear hatch.



T25 TORX

2. Inside the rear wheel well, behind the tire, locate the screw which is holding the bottom corner of the wheel well liner (green arrow). Remove this screw and fold the flexible liner back toward the tire. Behind the liner locate (3) additional screws and remove them (yellow arrows).



PASSENGER SIDE OF VEHICLE SHOWN



PAINTER'S TAPE



T25 TORX

3. To gain access to a screw in the fascia, the wheel well trim will need to be partially detached. Find the end of the clips inside the wheel well and press them down while using outward pressure to release them. Remove the (5) clips closest to the rear of the vehicle as shown. Apply painter's tape to the wheel well trim to protect it from damage. Remove the uncovered Torx screw. Repeat Steps 2-3 on other side of vehicle.



DRIVER SIDE OF VEHICLE SHOWN

GAIN ACCESS TO MOUNTING AREA CONTINUED



T25 TORX

4. Under the rear of the vehicle, remove (4) screws from the bottom of the fascia.



5. Inside the rear cargo area, remove the compartment storage side panels. Each panel has a knob that turns counter-clockwise to open. Inside the passenger side compartment, locate the 12 volt power supply outlet and unplug it. Squeeze the plug clips to release the plug.



NOTICE: Steps 6-9 are for Q5 / SQ5 non-hybrid vehicle installations. Skip to Step 10 if installation vehicle is a Q5 Plug-in Hybrid.



PLASTIC PRY TOOLS

6. **Q5 / SQ5 NON-HYBRID MODELS:** Lift up on the cargo floor panel and remove. In the rear of the cargo area, remove the threshold. Use a pry tool on the side of the threshold then lift up and remove.



GAIN ACCESS TO MOUNTING AREA CONTINUED



90 DEGREE PICK



T40 TORX

7. **Q5 / SQ5 NON-HYBRID MODELS:** Remove the tire jack, air compressor, spare tire cover, and spare tire from the rear cargo area. Locate and remove the (4) cargo hooks. Each cargo hook has a Torx screw hidden by a plastic cover. Use a 90 degree pick tool to open the cover and then remove the screw.

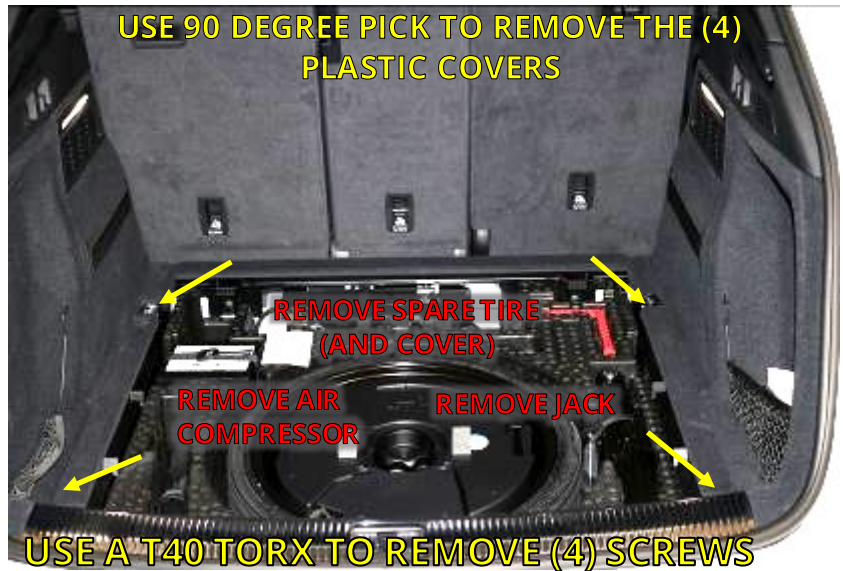

8. **Q5 / SQ5 NON-HYBRID MODELS:** Lift up and remove both plastic caps on each side of large foam support in the cargo area. Remove the insert in center front of the foam support. Carefully pull up one side of the large foam support to loosen it, then pull the entire foam support out of the cargo area.

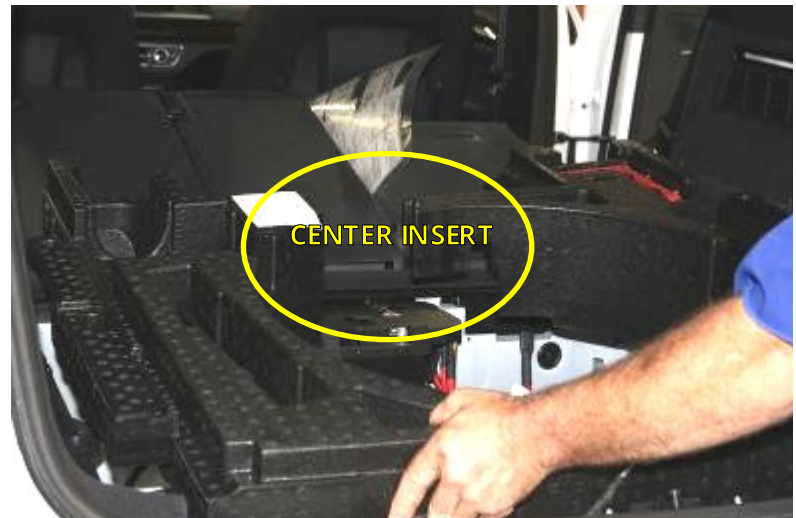

9. **Q5 / SQ5 NON-HYBRID MODELS:** Locate and remove the (2) rubber grommets in the rear of the cargo area, as shown in the image. Remove the (2) nuts located inside the holes covered by the grommets. Inside of the side cargo compartments, against the rear wall of the vehicle, are (2) additional nuts to remove.



10 mm HOLLOW NUT DRIVER



PLASTIC PRY TOOLS

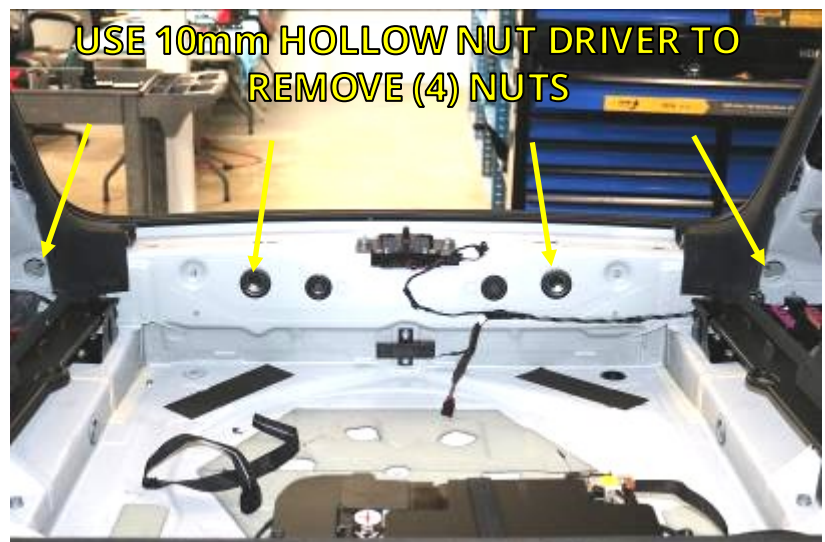

NOTICE: Skip to Step 15 to continue installation.

GAIN ACCESS TO MOUNTING AREA CONTINUED



T40 TORX

10. **Q5 PLUG-IN HYBRID MODELS:** On the floor of the rear cargo area locate the (4) cargo anchors in each of the corners of the floor panel. Use a T40 Torx to remove the (8) screws attaching the cargo anchors to the floor. Remove the cargo anchors. Lift up and remove cargo area floor panel set aside.

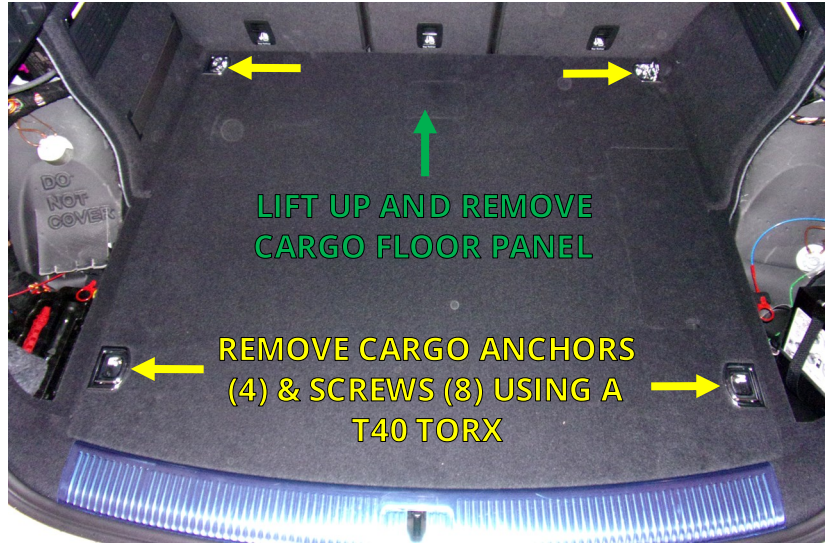

PLASTIC PRY TOOLS

11. **Q5 PLUG-IN HYBRID MODELS:** Remove the threshold in the rear cargo area. Use a pry tool on the side of the threshold then lift up and remove.



10mm SOCKET

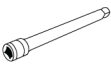

8" SOCKET EXTENSION

12. **Q5 PLUG-IN HYBRID MODELS:** Remove the foam piece shown in image. Use a 10mm socket and 8" socket extension to remove (4) nuts securing the large cargo area speaker. Unplug the speaker and remove.

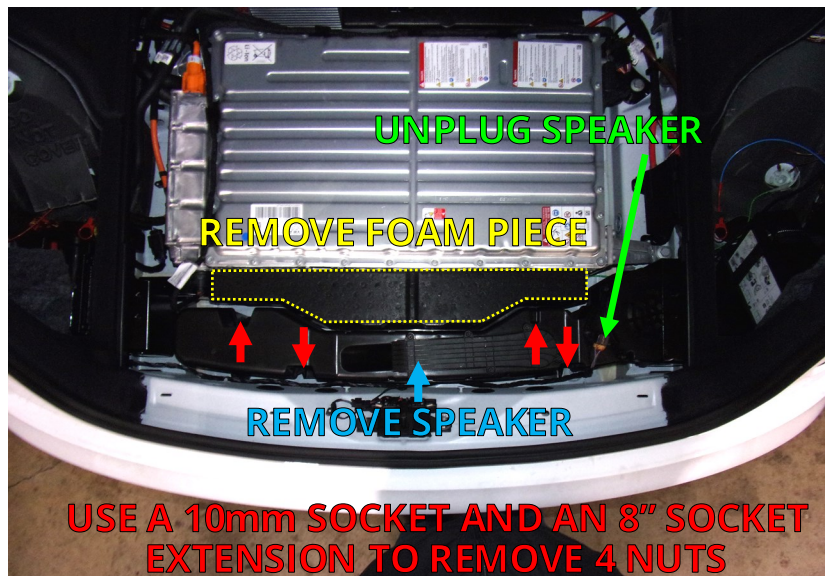

GAIN ACCESS TO MOUNTING AREA CONTINUED

13. **Q5 PLUG-IN HYBRID MODELS:** On the driver side of the vehicle, remove tool kit holder. On the passenger side of the vehicle, remove air compressor and plastic holder.



14. **Q5 PLUG-IN HYBRID MODELS:** Locate and remove the (2) rubber grommets in the rear of the cargo area, as shown in the image. Remove the (2) nuts located inside the holes covered by the grommets. Inside of the side cargo compartments, against the rear wall of the vehicle, are (2) additional nuts to remove.

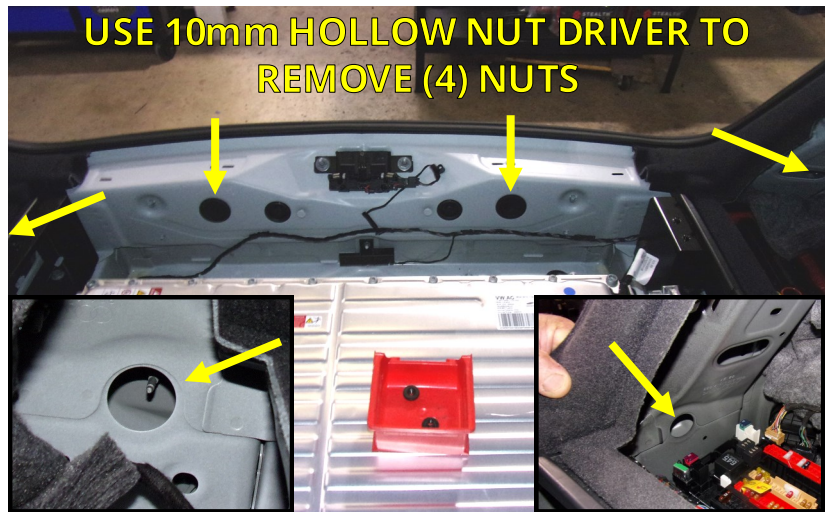

GAIN ACCESS TO MOUNTING AREA CONTINUED



15. The rear fascia is clipped to the vehicle body above and behind the wheel wells. Pull outward on the top front of the rear fascia to expose a clip in the seam. With a plastic pry tool, push down on the exposed clip to disconnect. Continue to pull outward on the fascia and disconnect clips as they are exposed.

Continue applying outward and rearward pressure until all the clips are released. Repeat on other side of vehicle.

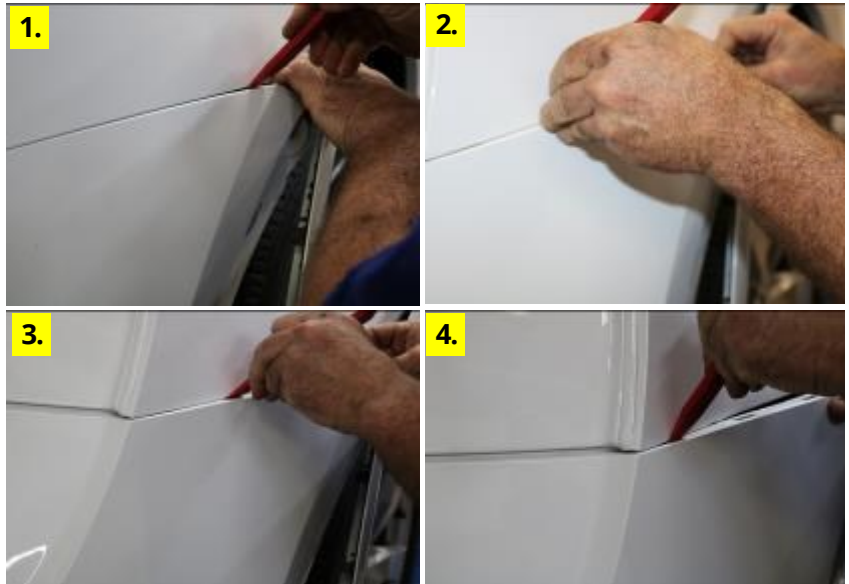

16. The fascia will not be completely disconnected from the vehicle, a wiring harness attached to the fascia must remain attached. Before removing the rear fascia, set up a stand or place a pad down near the rear driver side of the vehicle. Carefully pull the fascia away from the vehicle. Move the fascia away from the vehicle and place on the stand or pad prepared earlier.



NOTICE: Carefully remove the fascia and place on a blanket or pad.

NOTICE: If the electrical harness becomes disconnected the vehicle will need reprogramming at an Audi Dealership.



16mm
SOCKET

17. With the fascia out of the way, locate and remove the (8) bolts attaching the factory reinforcement beam to the vehicle. A long thin bracket will also be removed. Discard the (bolts) and bracket but save the factory reinforcement beam.

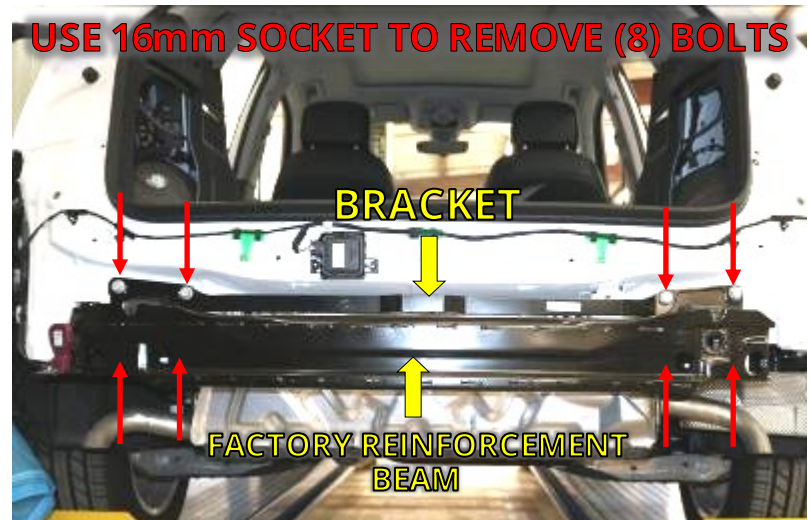

INSTALL STEALTH HITCH FRAME



17mm
SOCKET



TORQUE
WRENCH

18. Install the Stealth hitch frame and factory reinforcement beam onto the vehicle using (8) provided M10 bolts, washers, and lock washers, as shown. Center the hitch frame and beam before tightening. Use a torque wrench to tighten the bolts to 45 ft.-lbs.

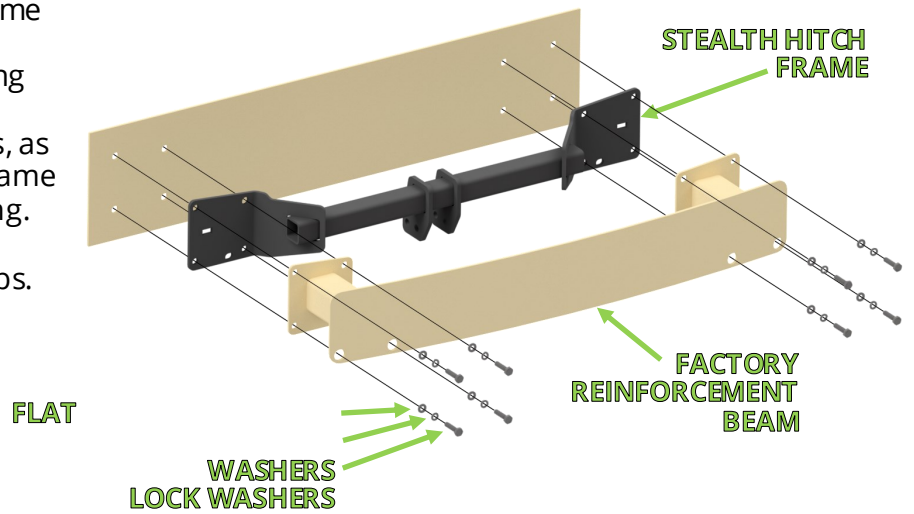

USE 17mm SOCKET TO TIGHTEN BOLTS

MOUNT LATCH BLOCK



15/16"
SOCKET



15/16" OPEN
END WRENCH



TORQUE
WRENCH

19. Installation of the latch block varies depending on which kit you are installing.

- **Rack Receiver Kit:** Install the latch block with (2) 5/8"-11 x 5" bolts and (2) 5/8" nylock nuts. Tighten each bolt to 150 ft.-lbs.
- **Tow Kit:** Retrieve Z-bracket from wiring harness kit box. Install the latch block, (2) chain hooks, and Z-bracket with (2) 5/8"-11 x 5" bolts and (2) 5/8" nylock nuts. Tighten each bolt to 150 ft.-lbs.

NOTICE: Keys are packaged within the latch block, remove keys and store in safe location.

RACK RECEIVER KIT INSTALL



TOW KIT INSTALL

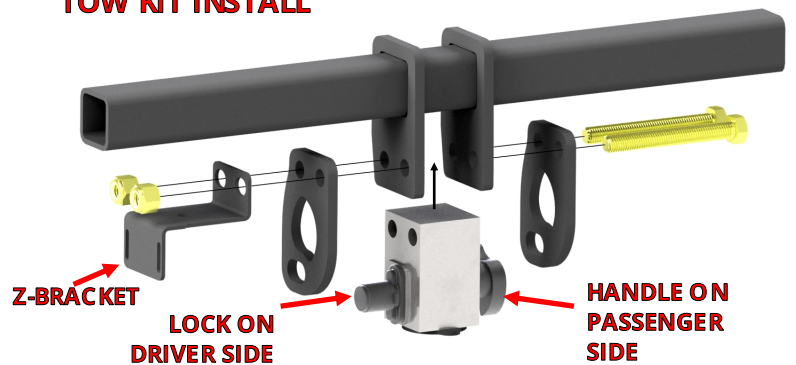

**IF INSTALLING A RACK RECEIVER KIT OR PLUG-IN HYBRID, SKIP TO STEP 34.
IF INSTALLING A TOW KIT, CONTINUE TO STEP 20.**

INSTALL PASSIVE WIRING KIT

#	DESCRIPTION	QTY
1	7-WAY WIRING HARNESS • FUSE HOLDER & FUSE • CONTROL MODULE & WIRES	1
2	ADHESIVE FOAM STRIP	2
3	FORK TERMINAL	1
4	CLAMP-ON CONNECTORS	5
5	5/8" LONG PHILLIPS SCREWS	6
6	#10 LOCK NUT	6
7	CABLE TIE - 8"	4
8	CABLE TIE - 14"	3
9	Z-BRACKET	1
10	MOUNTING BRACKET	1
11	7-WAY HOUSING	1
12	7-POLE TO 4-POLE ADAPTER	1



20. Locate the wiring kit box. Review the contents of the box against the list above to check for missing components. The passive wiring kit uses a control module to manage the functions of the trailer lighting. The module has an "input" side that receives power from the vehicle's battery and signals from the vehicle's taillights. The "output" side of the module delivers this information to the 7-way plug. The control module is connected to the vehicle's battery and taillight wiring as outlined in the next steps.

NOTICE: Do not allow electrical system to become disconnected from power or ground. Doing so may interrupt electrical systems.

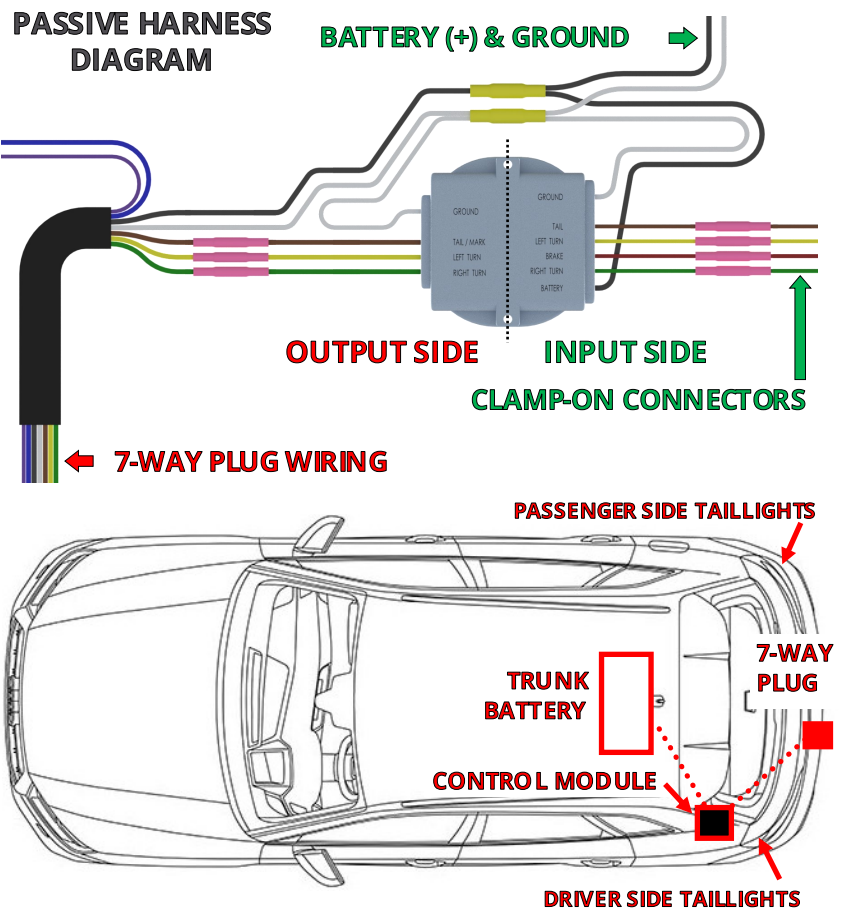

INSTALL WIRING KIT



DRILL &
3/8" BIT

21. On the floor of the rear cargo area, near the driver side, locate and remove the indicated rubber grommet. Drill a 3/8" hole into the grommet.



22. Retrieve the wiring harness and control module from the wiring kit box. Place the control module and harness inside the driver side cargo compartment. Pass the output wires through and under the metal support bar at the bottom of the compartment (see picture). Pass the grommet over the end of the output wires. Pass the output wires through the hole where the grommet had been. Replace the grommet into the vehicle floor.



PLIERS



MULTIMETER

23. Inside the driver side cargo compartment locate the indicated part of the vehicle wiring harness. Carefully remove the tape from around the wires. Using the clamp-on connectors, provided in the wiring kit, attach the input side wires of the wiring module to the vehicle wiring, use reference table on next page for wire colors.

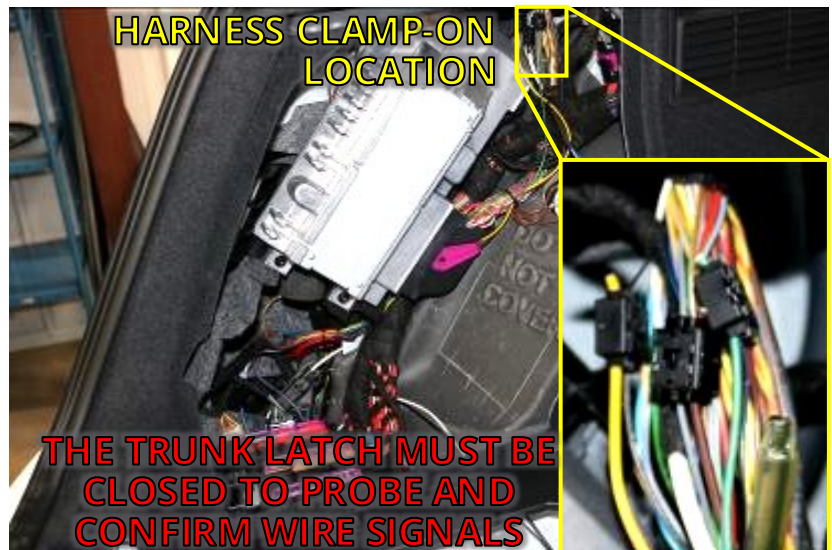

NOTICE: Verify wire signals with multimeter. Manufacturer may use different colors. The trunk latch must be closed when probing and confirming wire signals

CLAMP-ON CONNECTOR COLOR REFERENCE TABLE

SIGNAL INPUT WIRES				POWER & GROUND WIRES		
<u>FUNCTION</u>	<u>HARNESS</u>	<u>MODEL YEAR</u>	<u>VEHICLE</u>			
<u>LEFT TURN</u>	YELLOW	(2018-2020)	BLUE/BLACK	12V+ (POWER)	BLACK	BATTERY (+)
		(2021)	BLACK/GRAY			
<u>RIGHT TURN</u>	GREEN	(2018-2020)	BLACK/BLUE	GROUND	WHITE	BATTERY (-)
		(2021)	GRAY/YELLOW			
<u>MARKER</u>	BROWN	(2018-2020)	GREY			
		(2021)	GREY/GREEN			
<u>BRAKE</u>	RED	Do not connect the red brake wire. This vehicle does not utilize a separate brake circuit. The brake signal is sent down the left and right turn circuits simultaneously.				
<u>REVERSE</u>	PURPLE	For use with trailer reverse lights or to disable the trailer brakes when backing with surge brakes. To connect, isolate vehicle's reverse light circuit and connect the purple wire from the trailer wiring harness to vehicle reverse light circuit. Trailers rarely have reverse lights or surge brakes.				
<u>ELECTRIC BRAKE</u>	BLUE	Only used when a hard wired brake controller is mounted inside the vehicle and your trailer has electric brakes. See brake controller instructions for this wire.				

NOTE: If two colors are listed, the first color is the dominant color.

24. Pass the power and ground wire from inside the driver side cargo compartment and under the metal support bar at the bottom of the compartment (see picture). Route the wires to the battery following existing wiring where possible.



25. Locate the fork terminal supplied in the wiring kit box. Trim excess ground wire length. Crimp the fork terminal to the ground wire. Connect the ground wire to the negative battery terminal (-).

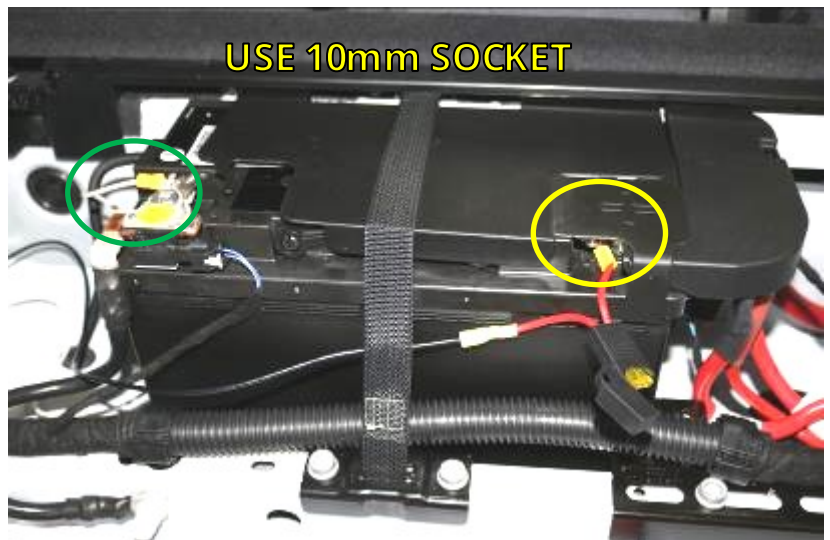

26. Locate the fuse holder supplied in the wiring kit box. Remove the fuse from fuse holder. Trim excess power wire length. Crimp fuse lead to power wire. Connect fuse ring terminal to the positive battery terminal (+).

NOTICE: Loosen battery terminals just enough to install wiring, so vehicle wiring does not lose ground or power.

INSTALL WIRING KIT CONTINUED

27. Retrieve the adhesive foam strip from the wiring kit box. Secure the control module to a body panel inside the driver side cargo compartment.

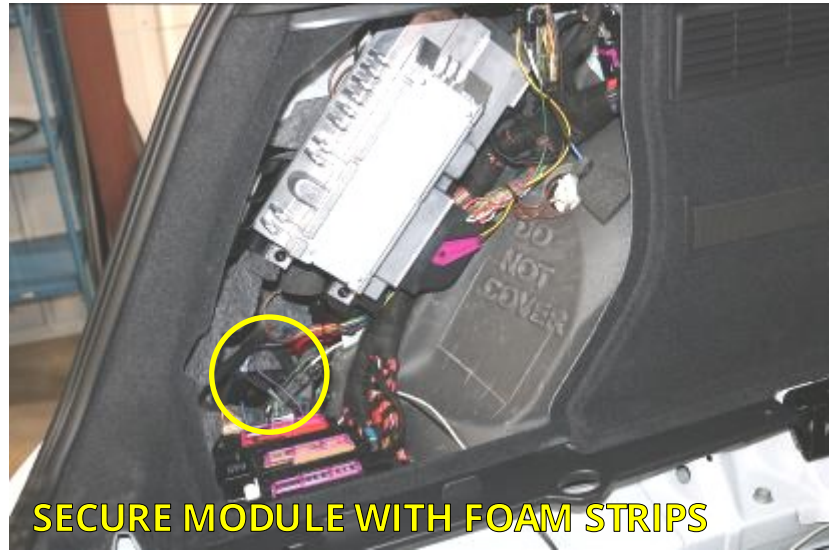

WIRE 7-WAY PLUG



PHILLIPS HEAD
SCREWDRIVER

28. Locate the 7-way housing. Use a screwdriver to loosen (2) screws. Remove 7-way round terminal block. Place the mounting bracket onto the 7-way housing as shown. Use a screwdriver to loosen the set screw at the bottom of the 7-way housing. Route output side wires of the wiring harness through the 7-way housing.

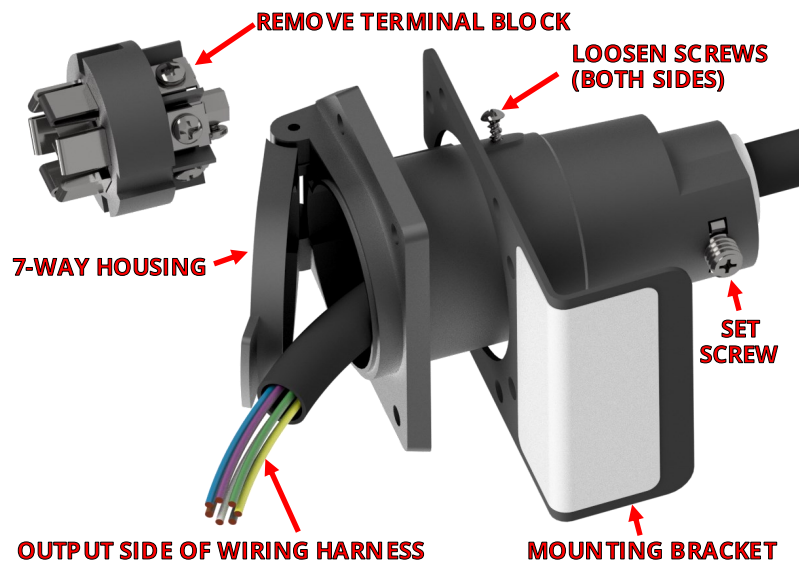

Please follow instructions below very carefully.
Incorrect wiring of the 7-way receptacle causes the vast majority of wiring problems.



PHILLIPS HEAD
SCREWDRIVER

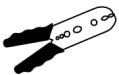

STRIPPER/
CRIMPING
TOOL

29. Locate the slot keyway. Starting from the keyway going **clockwise**, attach the wires as follows:
- Blue
 - Green
 - Black
 - Brown
 - Yellow
 - White
 - Purple (middle)

NOTICE: Markings on the receptacle may not match the correct wire configuration. Please disregard and follow the instruction above.

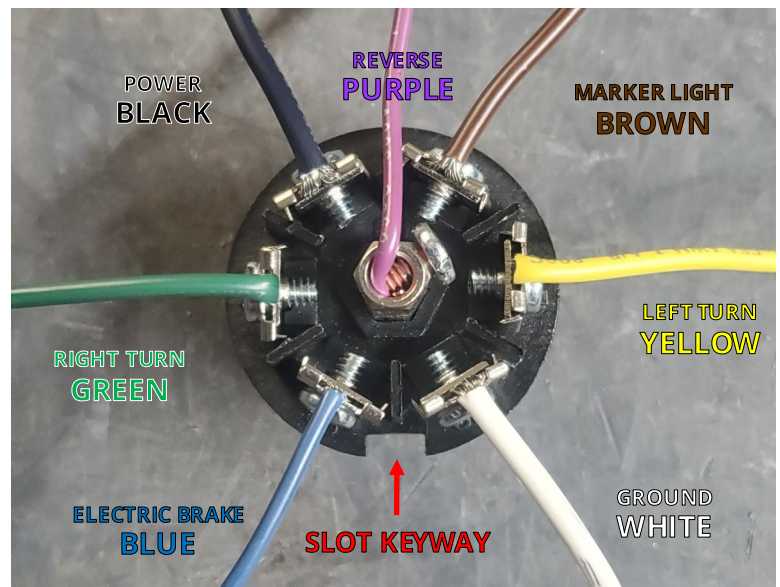

TEST 7-WAY HARNESS WIRING



PHILLIPS HEAD
SCREWDRIVER



MULTIMETER

30. Put the 7-way receptacle back together. While everything is still accessible, you should test the wiring to make sure everything is connected properly and in working order. **Replace the 20 Amp fuse into the fuse holder located near the battery.**

NOTICE: The trunk latch must be closed when probing and confirming wire signals

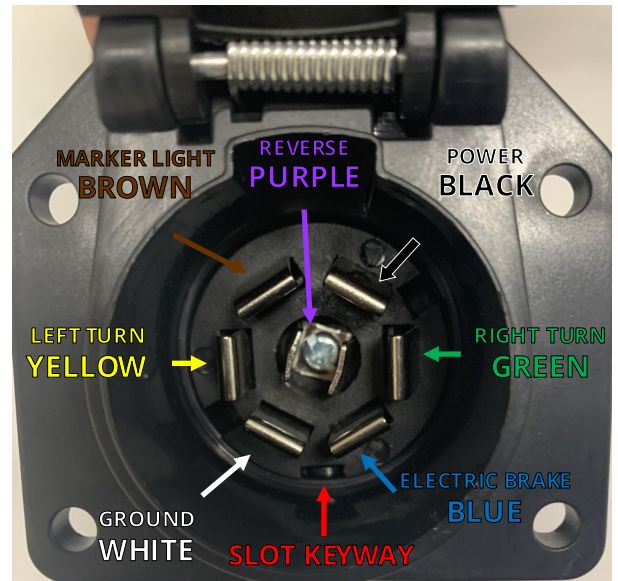

- Start by connecting the multimeter negative probe to the ground blade on the 7-way receptacle.
- Next, connect the multimeter positive probe to the power blade on the 7-way receptacle and check for 12 volts.
- Once that is confirmed, move the positive probe to the left turn blade on the 7-way receptacle and check for 12 volts when the vehicle left turn blinker is active. You should see it pulse.
- Next, move the positive probe to the right turn blade and check for 12 volts when the right turn blinker is active. You should see it pulse.
- Next, move the positive probe to the marker/taillights. With the vehicle lights on you should see 12 volts constant.
- Lastly, with the brake depressed, move the positive probe to the left turn blade where you should see 12 volts constant. Move the probe to the right turn blade where you should also see 12 volts constant.



PHILLIPS HEAD
SCREWDRIVER



SILICONE

31. Attach the mounting bracket and 7-way housing to the Stealth hitch frame as shown. Secure harness to Stealth hitch frame with cable ties.

32. Secure all wires and wiring components. Use the remaining cable ties to secure wiring so that it is not loose and will not interfere with replacement of the fascia. Wiring should not be visible once the vehicle is reassembled.

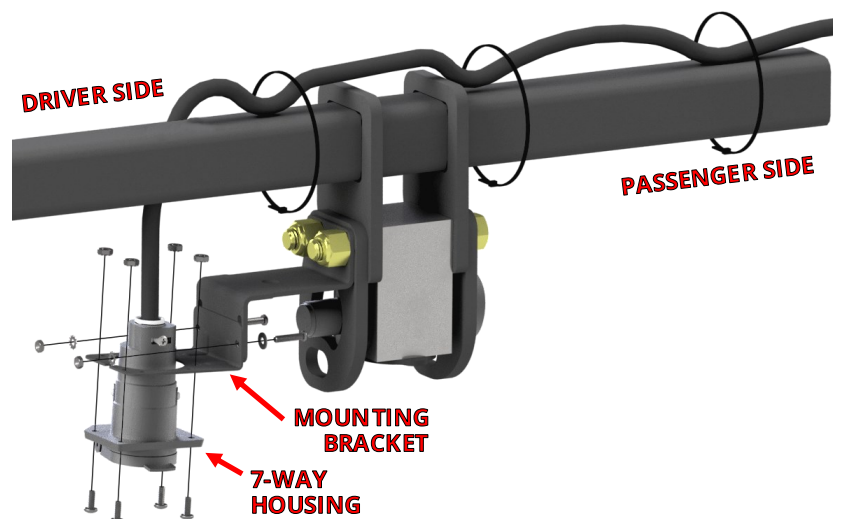

33. Use silicone to waterproof the grommet.

REINSTALL VEHICLE COMPONENTS

34. Reattach and secure the fascia and other vehicle components in reverse order. Refer to Steps 1-11.



35. The finished, under vehicle view.

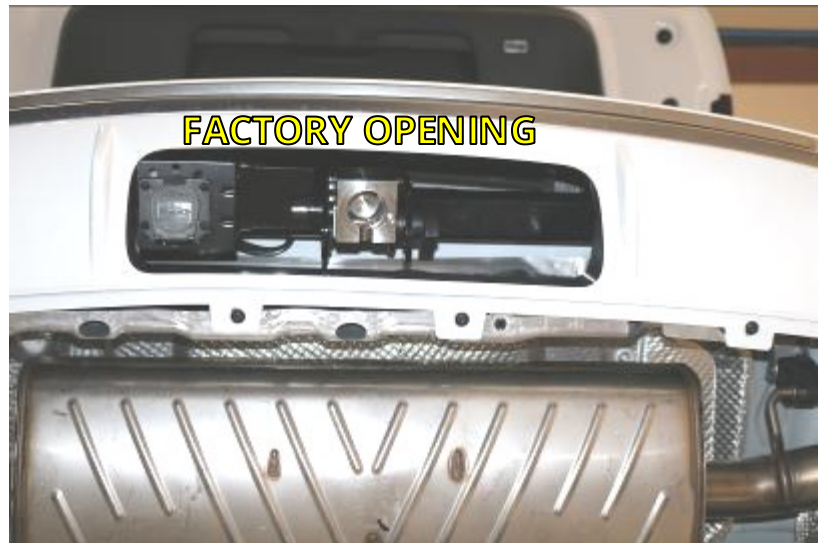

FINAL VEHICLE EXAMINATION

36. Examine the body panels to ensure that they are in a pre-installation condition. Test the electronic functions of the vehicle. Correct any inconsistencies.
37. Ensure that hitch components work properly.
 - **Verify that the lock works correctly.** Push in the safety lock on the latch block then unlock with key. The lock should slide back out with the key when unlocked.
 - **Verify that each accessory can be installed correctly.** Use the following steps to install and remove each accessory that will be used with the hitch. (*Rack Receiver* and *Ball Mount* if purchased.)
 1. Prepare latching mechanism. Turn handle clockwise if needed.
 2. Firmly insert "post" of accessory into latch block until handle releases indicating that the accessory is latched.
 3. Push in the safety locking pin until it fully engages. The locking pin prevents the handle from turning when pushed in, and confirms that the block is securely latched onto the accessory. The safety locking pin will not depress if the accessory is not fully latched.
 4. Use key to release safety locking pin.
 5. While holding on to the accessory, rotate handle clockwise to release and remove the accessory.
 - **Verify that no part of the accessories come into contact with the body of the vehicle.**

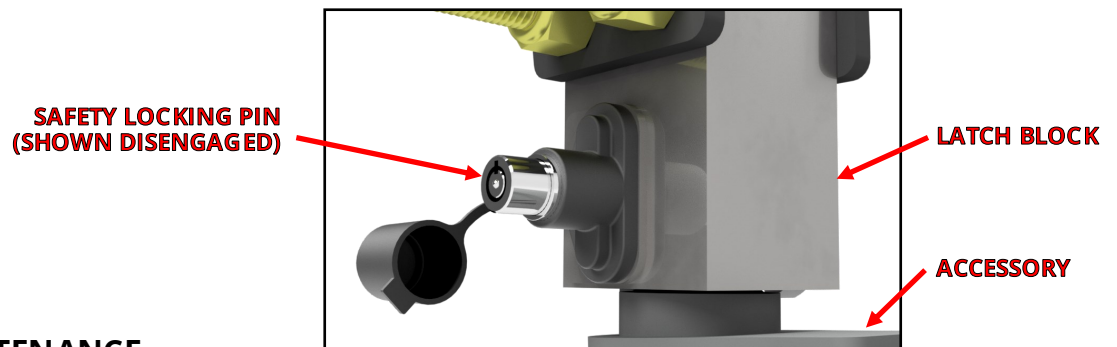

PRODUCT USE AND MAINTENANCE

NOTICE: If the hitch is being installed by a professional, the installer is responsible for training the end user in the use and maintenance of the product.

- **Accessory installation procedure:**
 1. Prepare latching mechanism. Turn handle clockwise if needed.
 2. Firmly insert "post" of accessory into latch block until handle spins counter-clockwise indicating that the accessory is latched.
 3. Always depress the safety locking pin and check that it has fully engaged.
- **Never use any accessory with the safety lock disengaged.** Until the safety locking pin is engaged, the handle is able to turn. A fully engaged safety locking pin is confirmation that the accessory is properly latched into the latch block.
- **Never use the rack receiver for towing.** The rack receiver accessory is only to be used with payload carrying products, such as bike racks or luggage racks.
- **Before each use, give the post of the accessory a light coating of lithium based grease.**
- **Before each use, inspect the hitch to ensure that all bolted connections are secure and that no cracks or damage are present.** Do not tow with the hitch if cracks or damage outside of normal wear is found.
- **Remove the Stealth accessories from the latch block after each use.** Do not leave accessories plugged in for extended periods of time.