

SYA Install



Deflate front and rear air struts.
We recommend using a GAP Diagnostic tool.



Remove front and rear air struts.

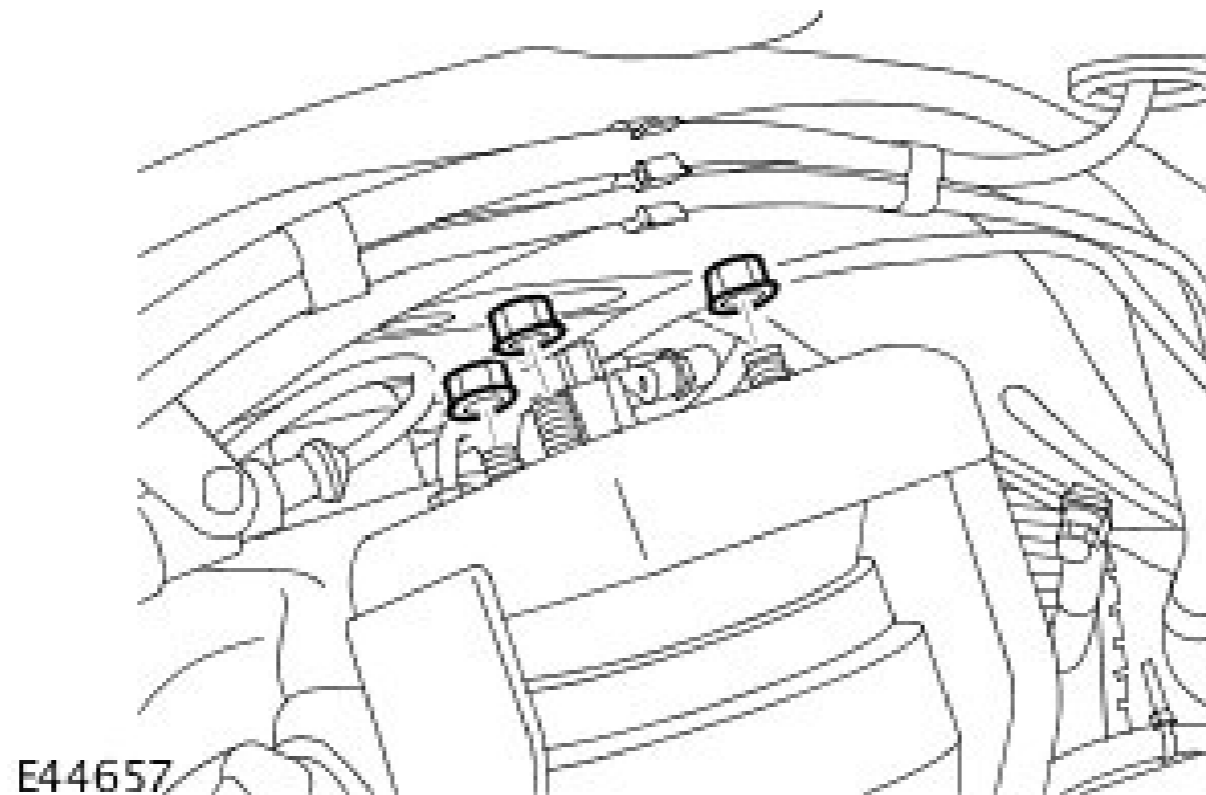
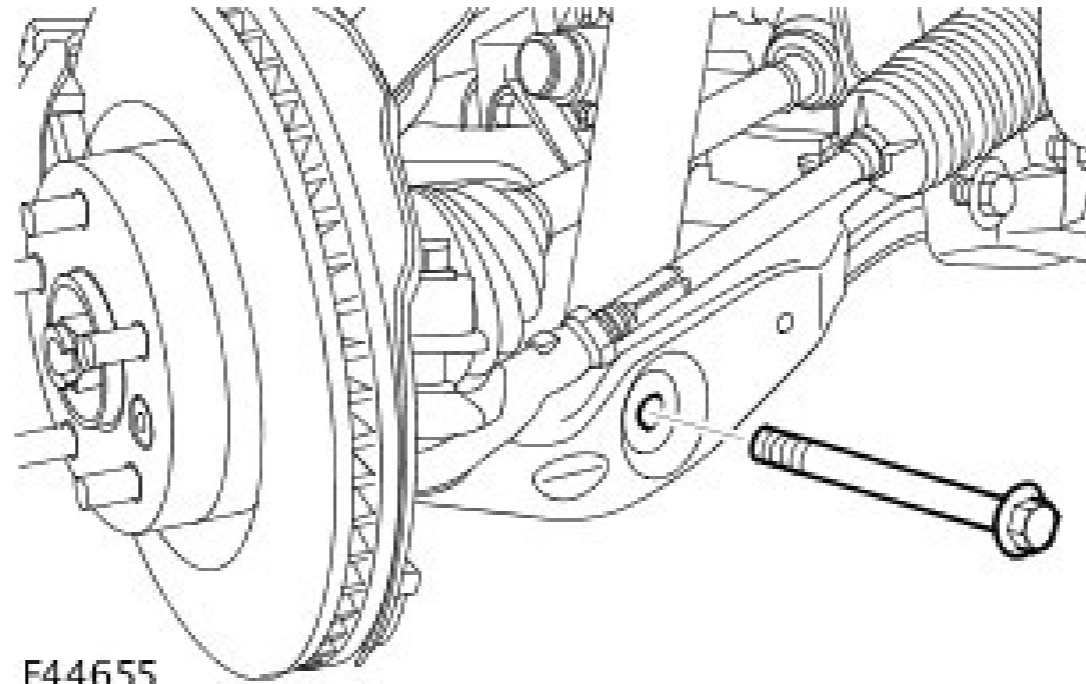

Bolt the SYA spacers on top of the air struts.
Torque to 63 Nm.

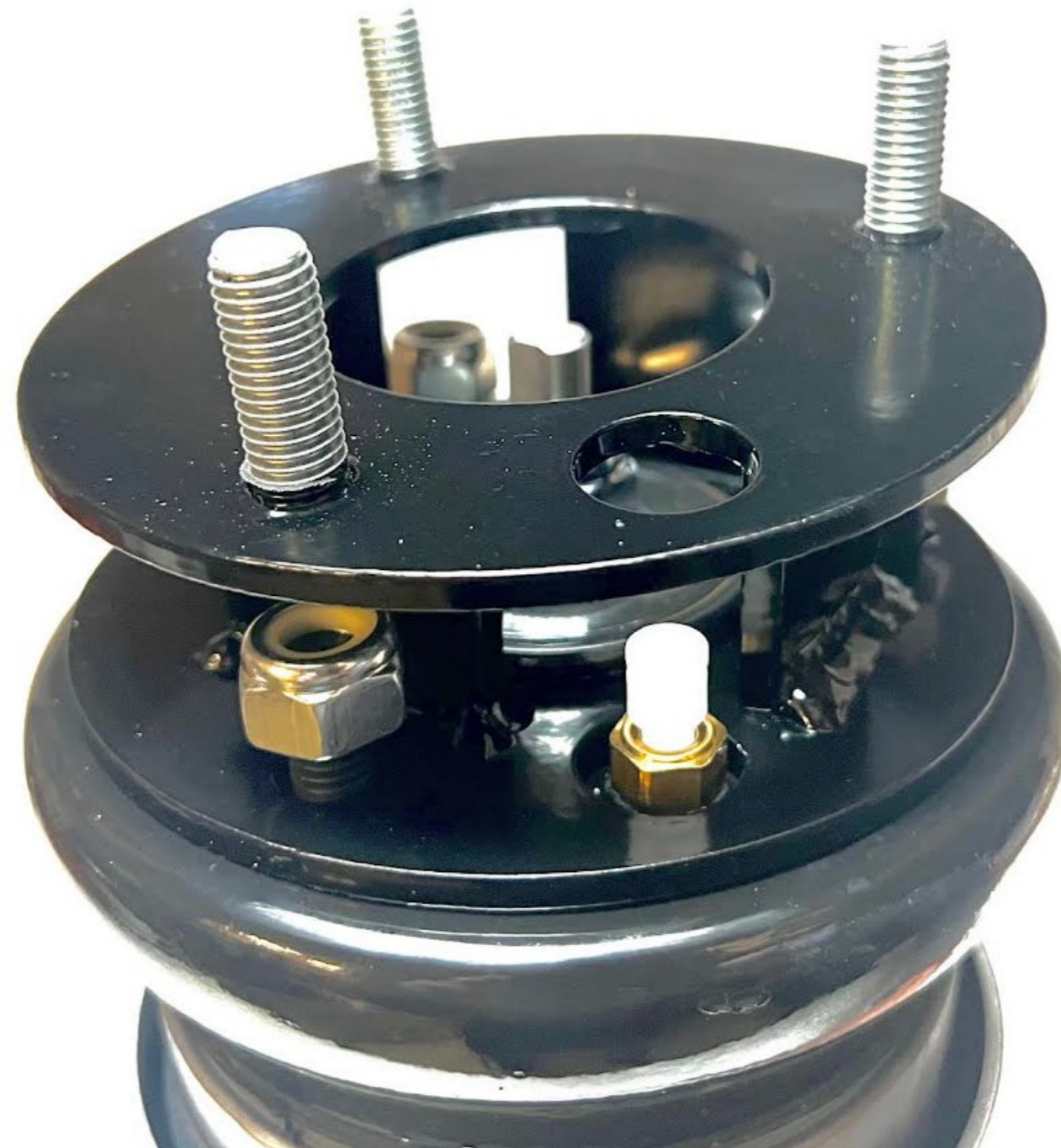

Install the air line extensions.



Cut the flared end off of the factory air line.

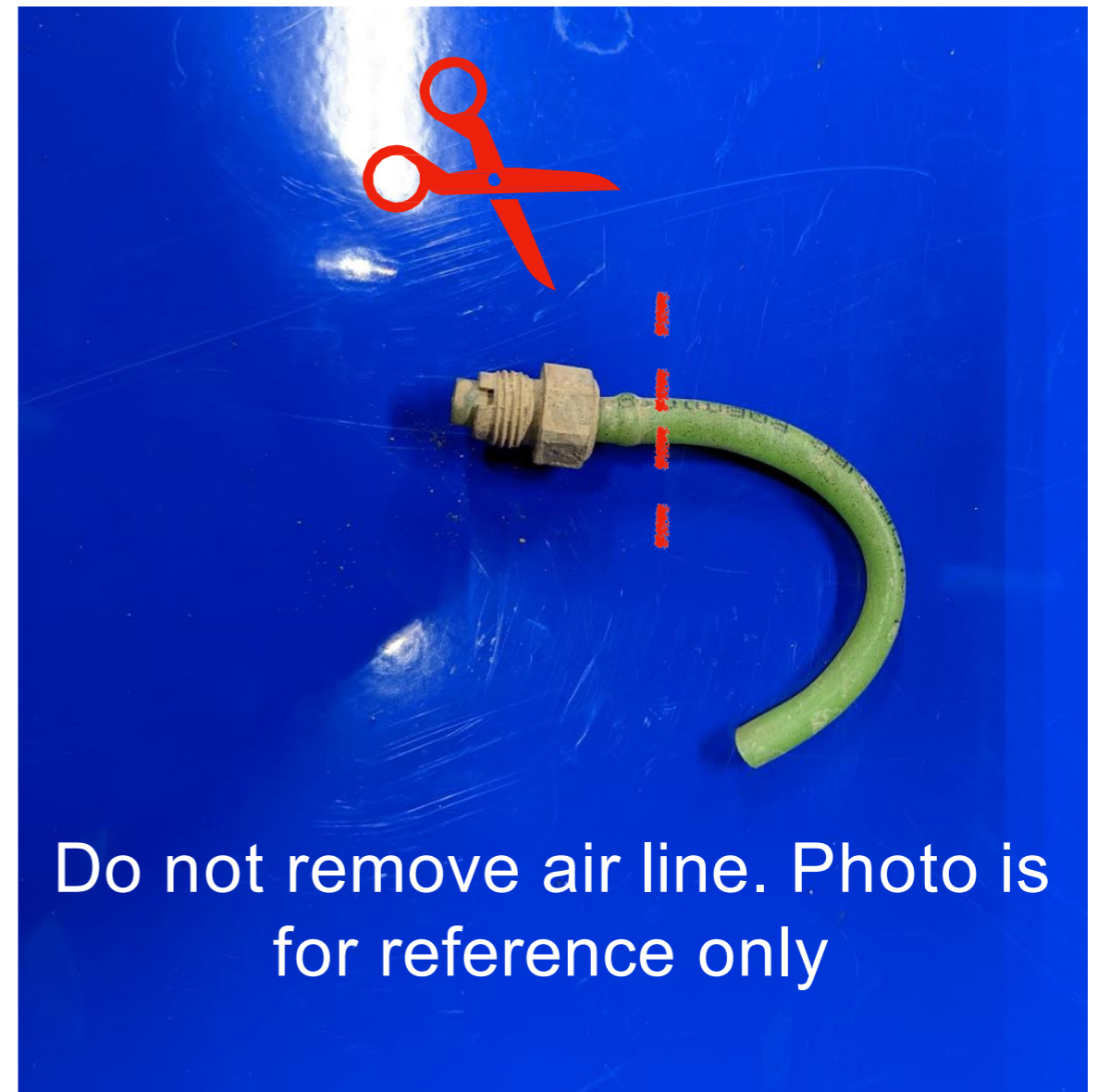

Do not remove air line. Photo is for reference only

Bolt air struts back in and connect the air lines with the quick connect fitting. Top nuts torque to 63Nm. Lower shock bolt torque to 300Nm.

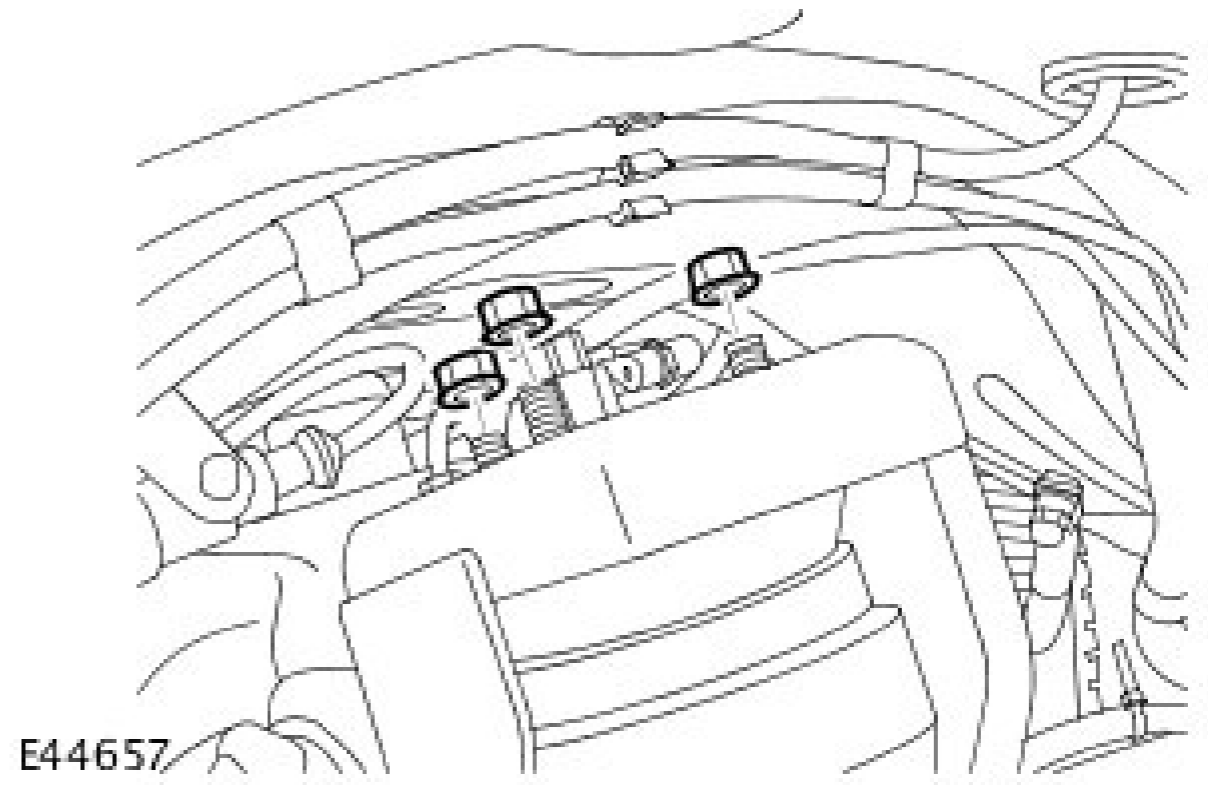
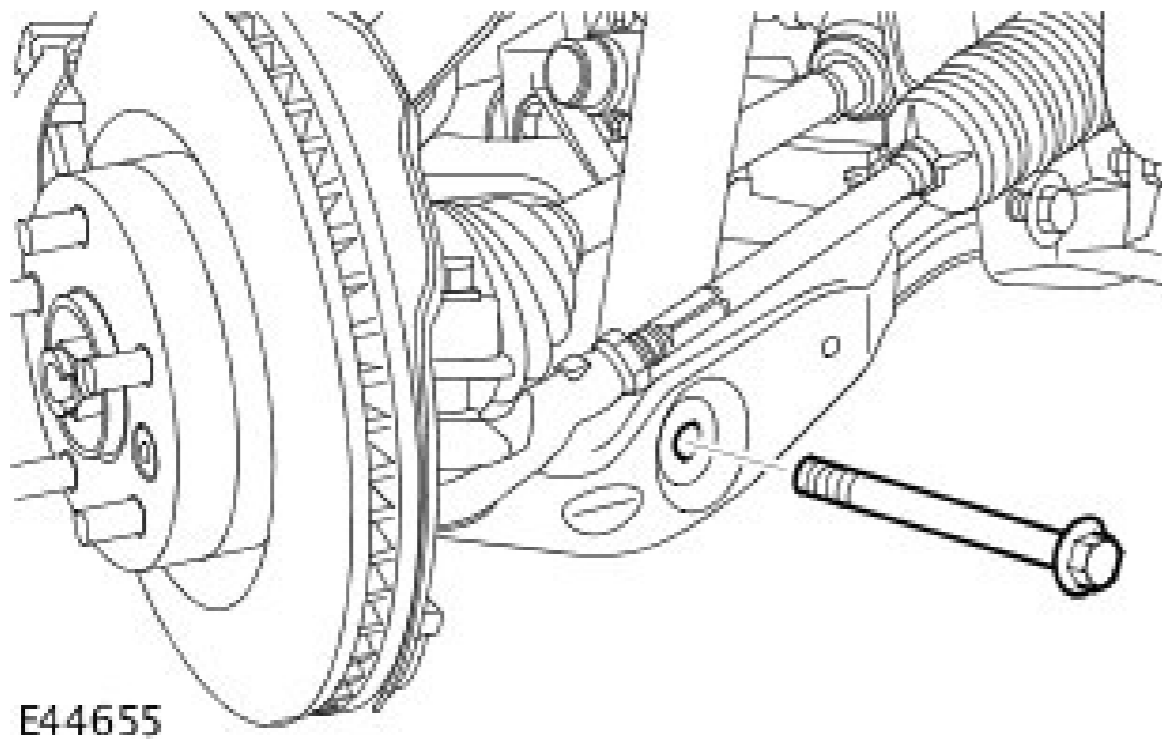

If used, connect the limiting straps to the rear as shown.



Rear locking tab orientation. Tight nut to 133Nm



If used connect, the limiting straps to the front as shown.

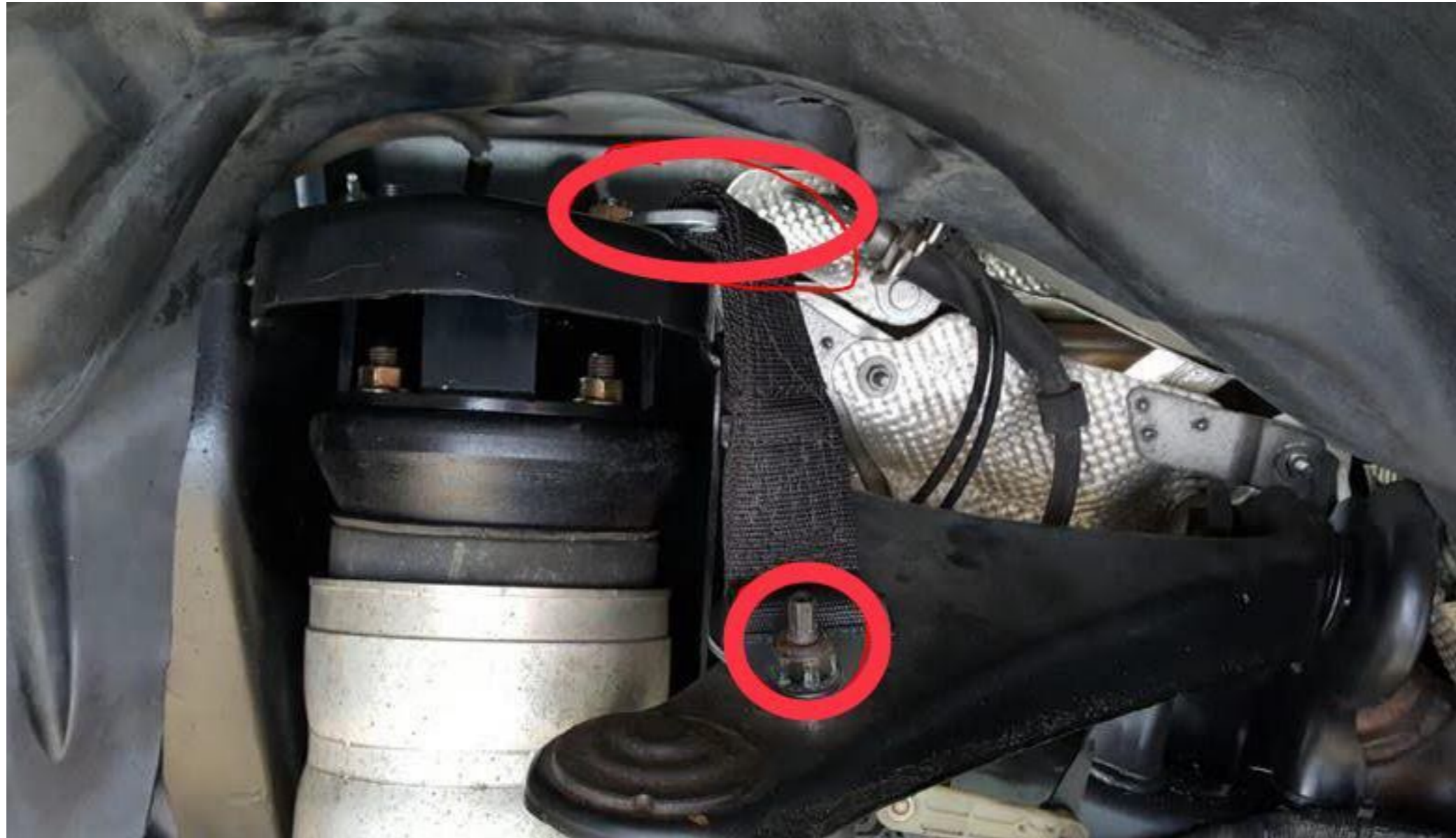

Get out there and explore with confidence!

