

INSTALLATION MANUAL



**READ CAREFULLY
BEFORE INSTALLATION**



**WASH BEFORE
INSTALLING**

FRONT BUMPER GUARD WITH DRL'S
AD PART #: GM39A04

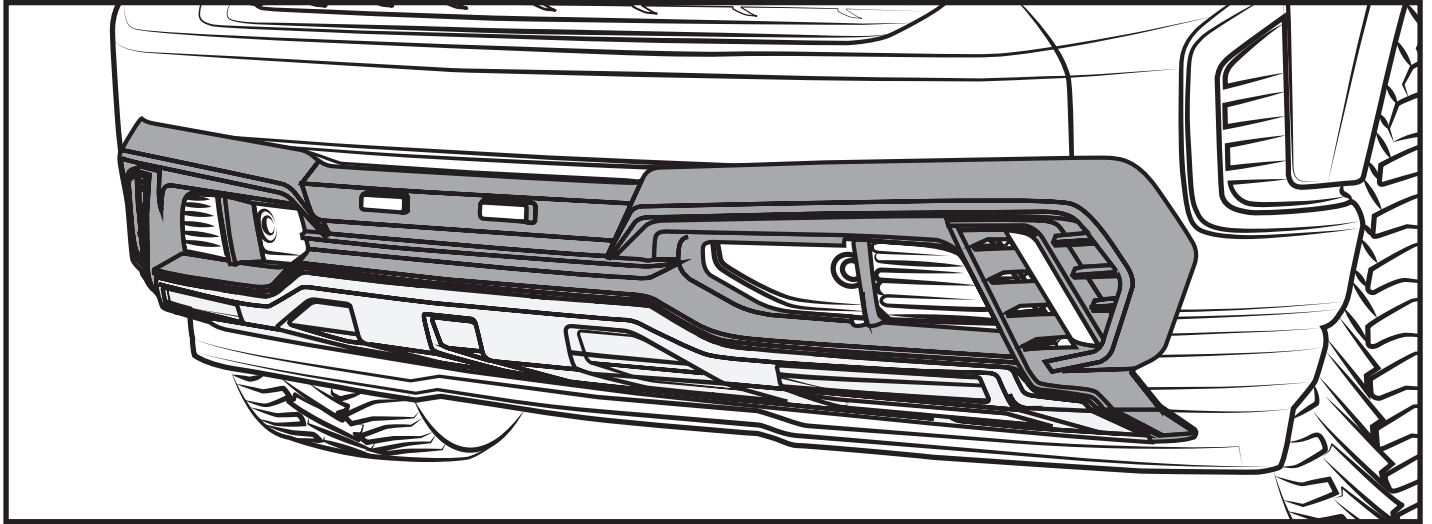

**WE RECOMMEND
2 PERSONS FOR
INSTALLATION**

AFTER INSTALLING

**DO NOT
WASH CAR**



24 hrs

**DRIVE SLOWLY
25 mph max**

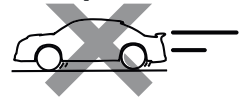

TOOLS

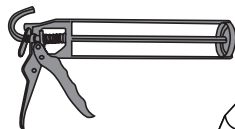

10 mm





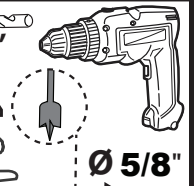
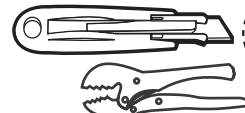



1/4"

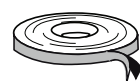
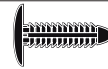

Ø 5/8"

CHECK LIST

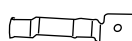
***Already installed in the part**

ITEM	DESCRIPTION	DRAWING	AMOUNT
A	*VHB TAPE		INCLUDE IN THE PARTS
B	PUSH PIN WURTH 501 111 46		7 PCS
C	DRL LED OSRAM PX-5		1 PC
D	AUTOMOTIVE ADHESION PROMOTER		1 PC
E	QUICK SPLICE TAP CONECTOR		1 PC
F	FUSE TAPS BP/ATM-TAP-RP		1 PC
G	INSULATED FEMALE CONNECTOR BP/ATM-TAP-RP		1 PC
H	POLYURETHANE ADHESIVE 310 ml		1 PC

INSTALLATION MANUAL

0 DRL INSTALLATION

- 1** PLACE CONTROL BOX
- 2** CONNECTION TO FRONT LIGHT
- 3** BATTERY
- 4** FRONT (ENGINE) FUSE BOX

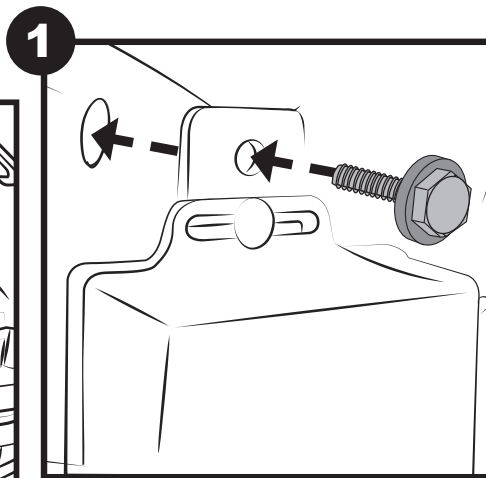
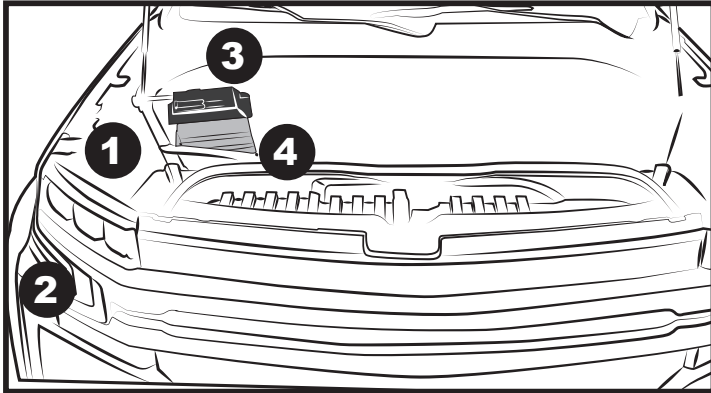

- a** REMOVE SCREW.
- b** PLACE THE CONTROL BOX.
- c** SCREW.

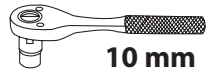

CONTROL BOX WIRES CONNECTION

- **ORANGE:** CONNECT TO 92 SLOT IN FRONT (ENGINE) FUSE BOX.
- **RED:** BATTERY POSITIVE (+)
- **BLACK:** BATTERY NEGATIVE (-).
- **GREEN:** CONNECTED TO YELLOW HEADLIGHT WIRE COPILOT SIDE.

2

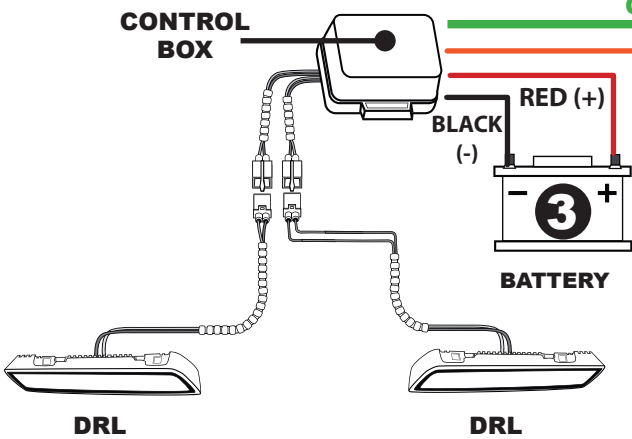
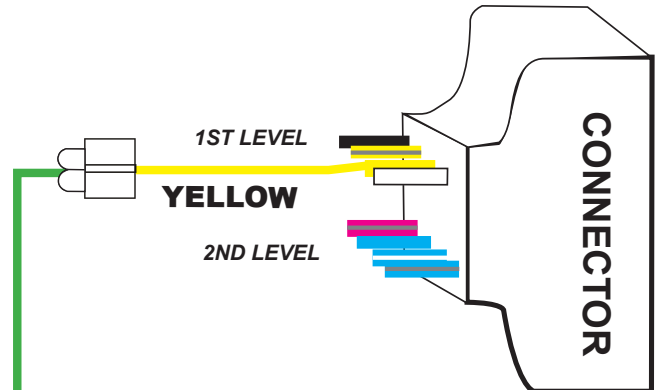
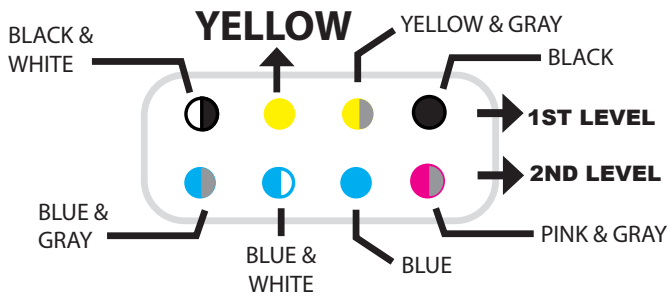

FUSE 92

FRONT (ENGINE) FUSE BOX

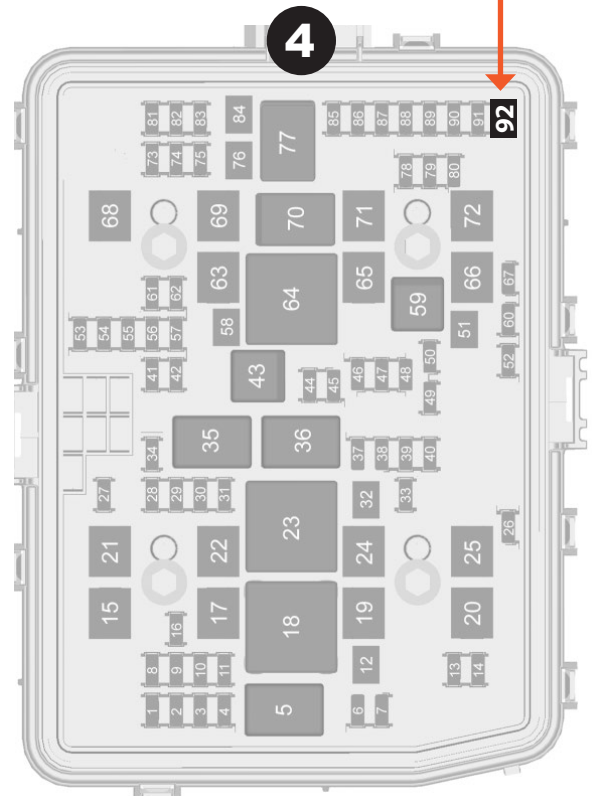

ADD-A-CIRCUIT

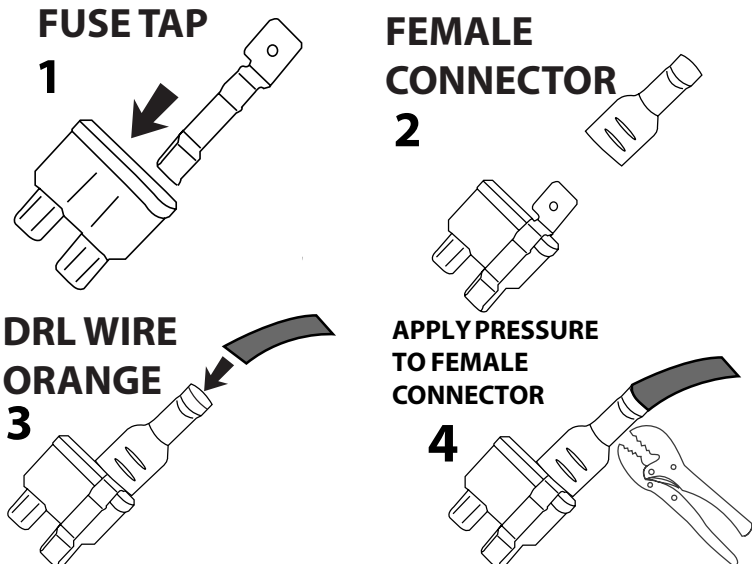

INSTALLATION MANUAL

The ideal temperature range of the part and the vehicle when installing must be 16°C (60°F) to 40°C (104°F), this guarantees a correct assembly.

1 CLEAN

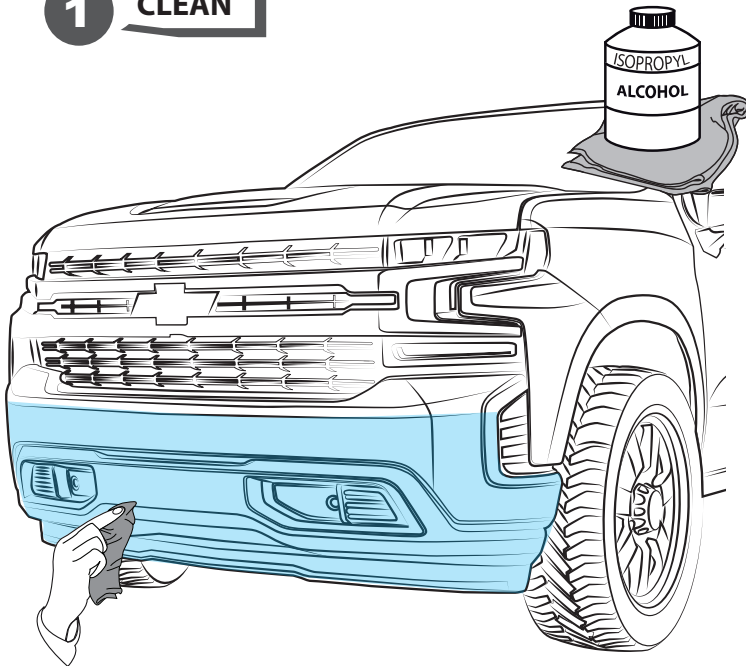

2 PRE-INSTALL

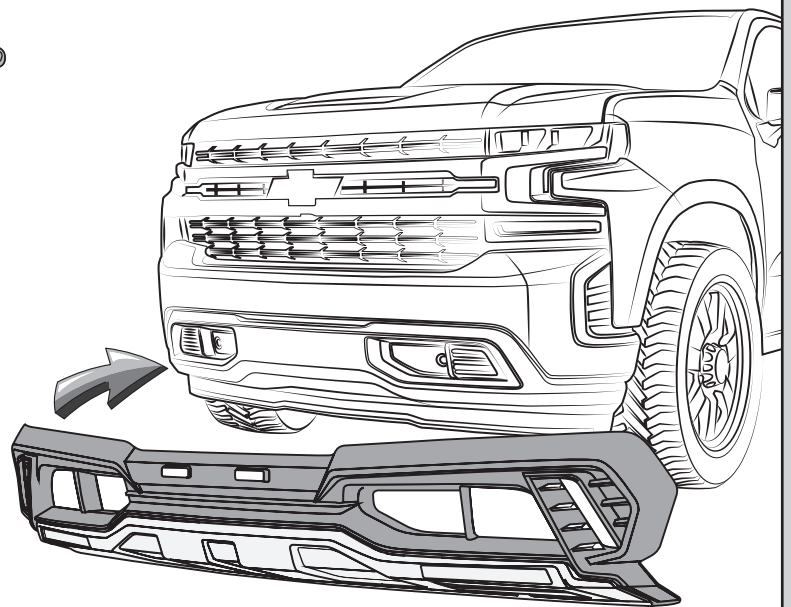

3 MARK

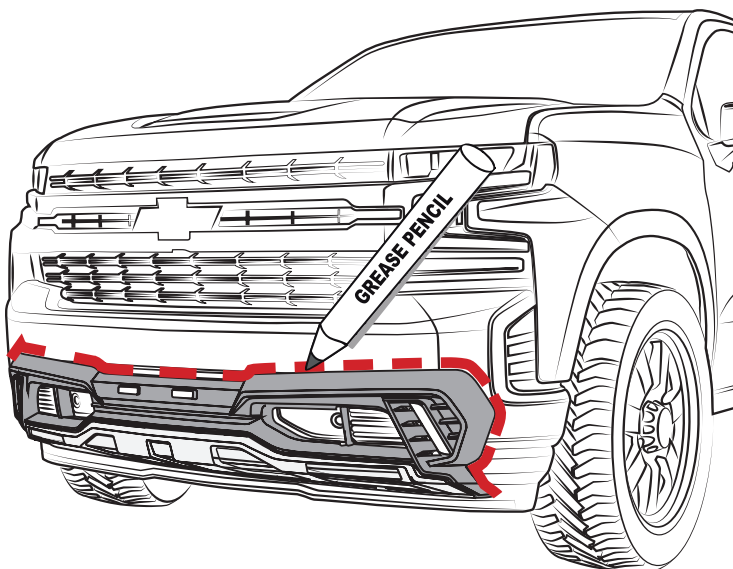

4 REMOVE

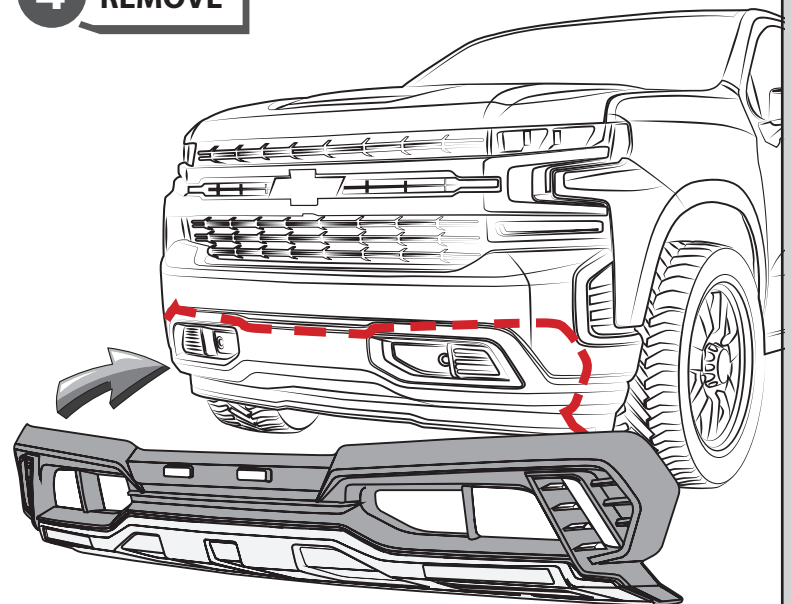

5 APPLY ADHESION PROMOTER

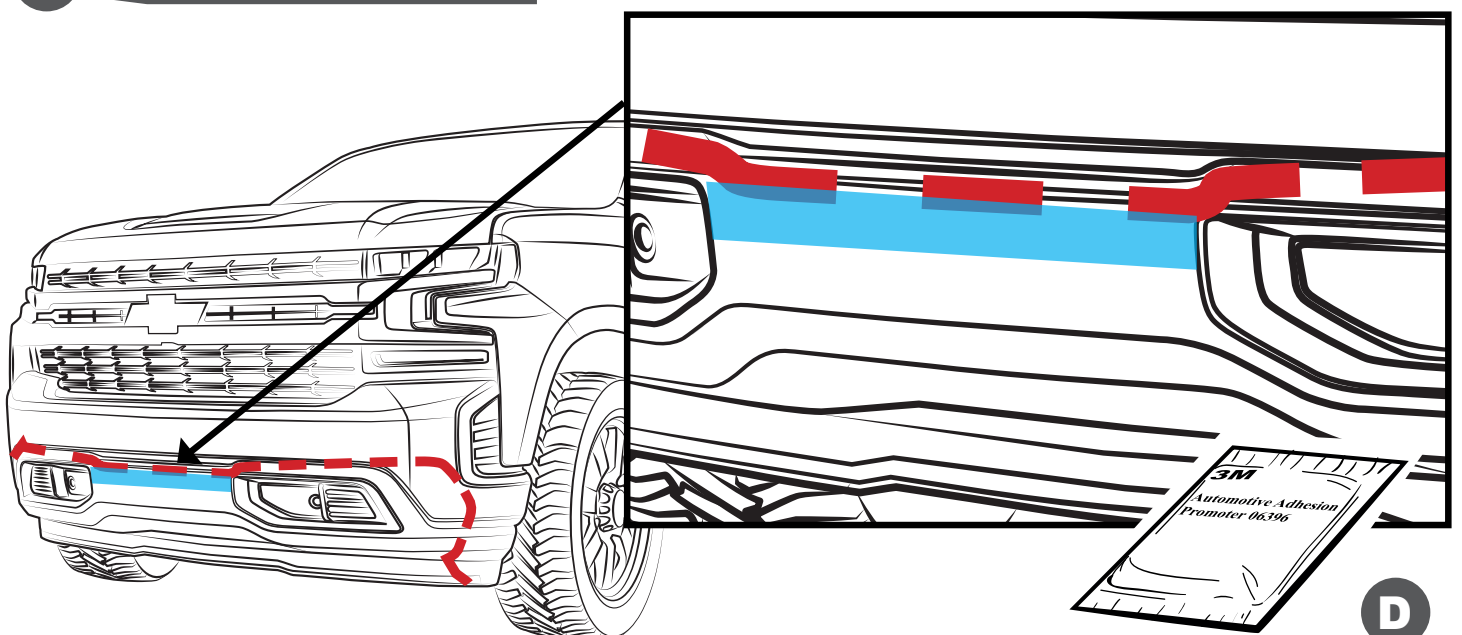

INSTALLATION MANUAL

6 CLEAN INNER CHANNEL

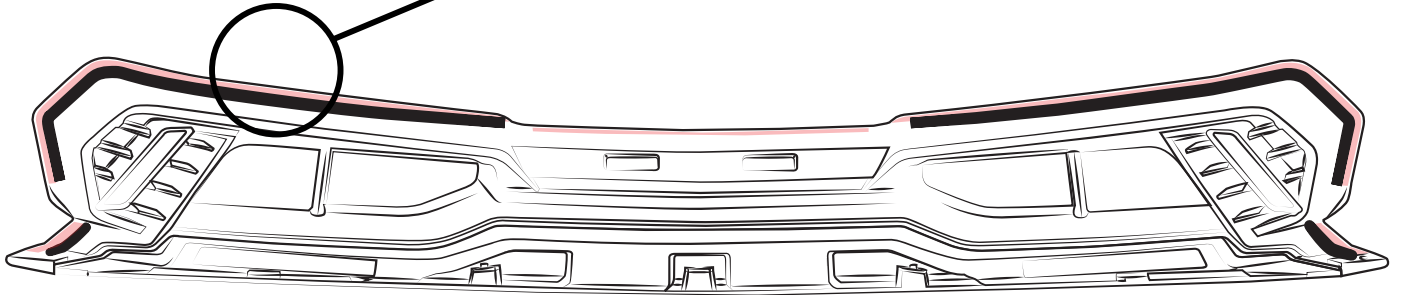
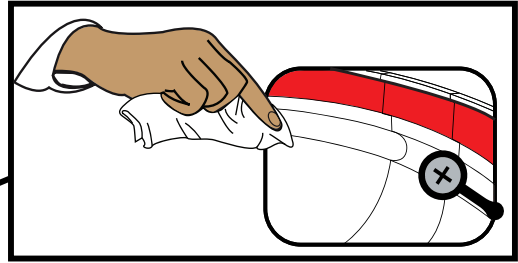

7 PEEL

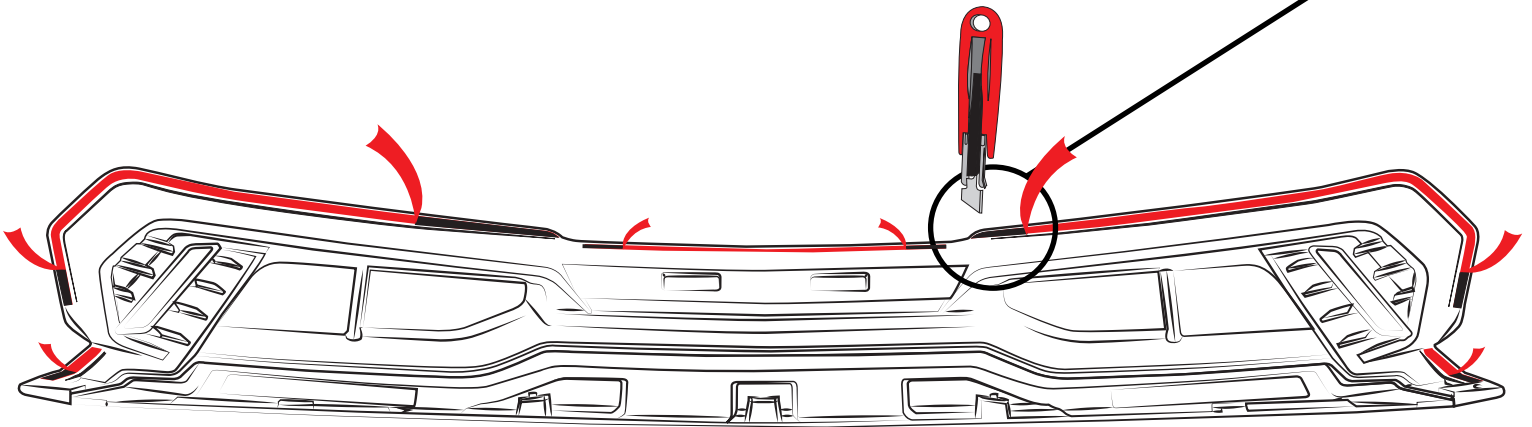
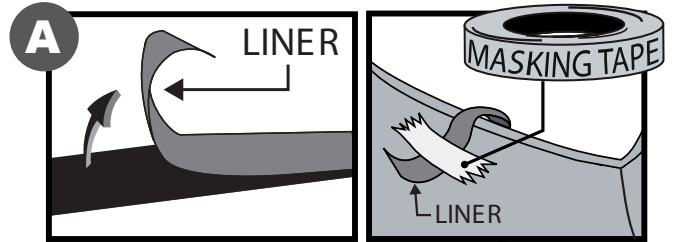

8 APPLY POLYURETHANE ADHESIVE

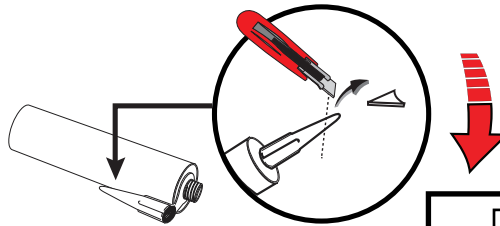

! POLYURETHANE ADHESIVE MUST NEVER TOUCH THE DOUBLE SIDED TAPE

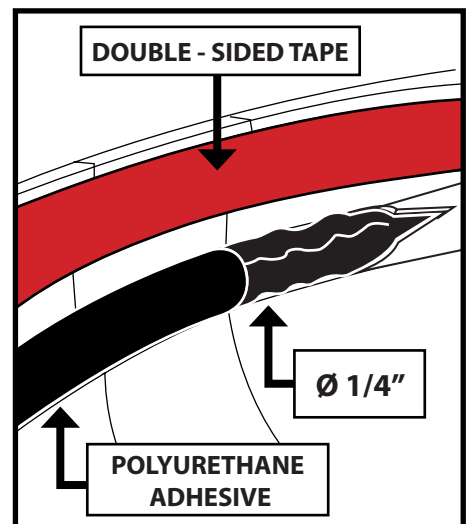
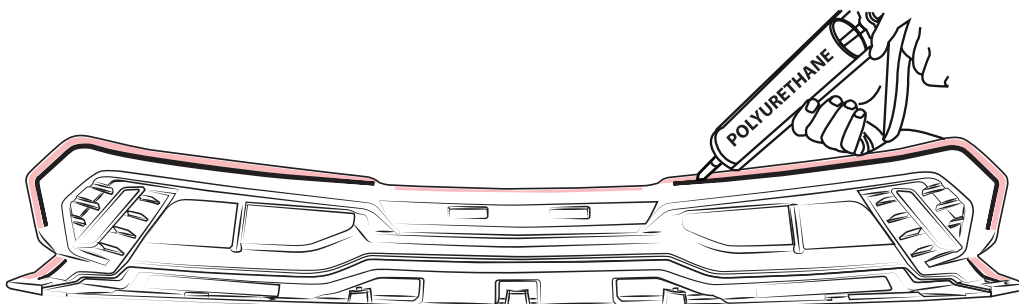

INSTALLATION MANUAL

9 DRILL

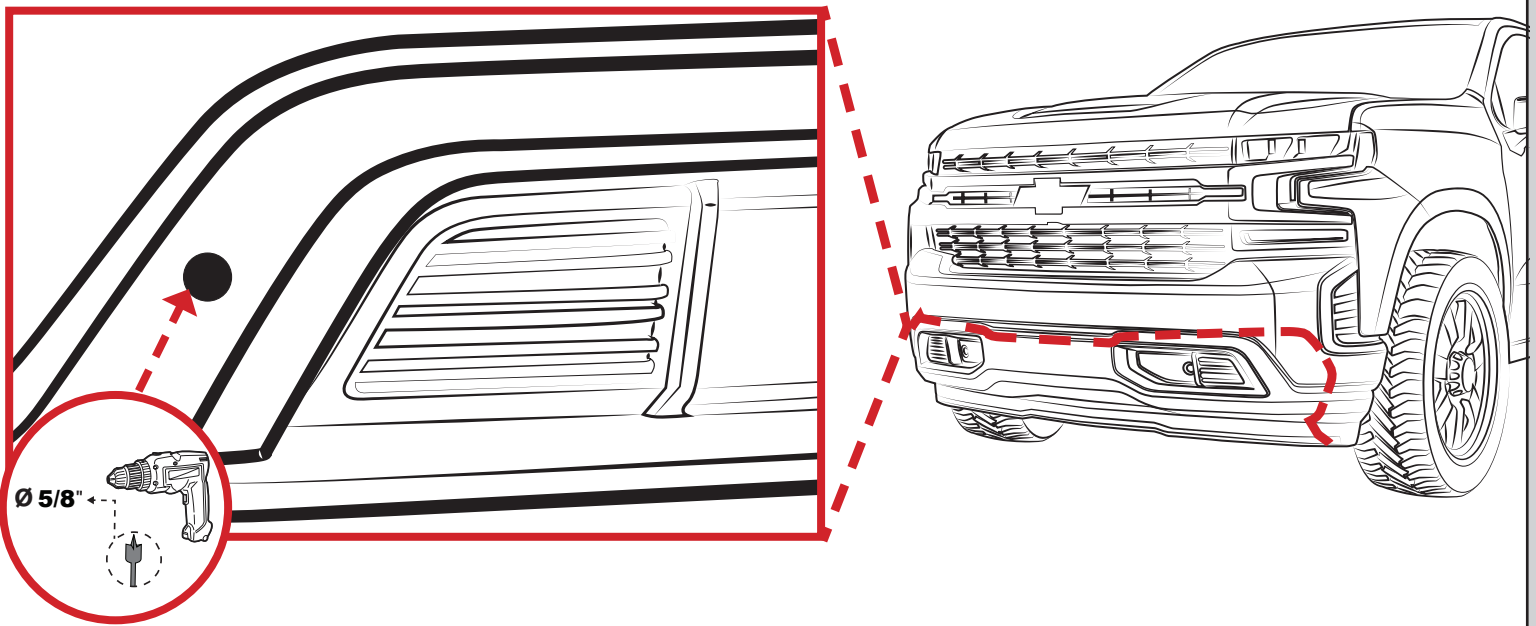

10 PLACE

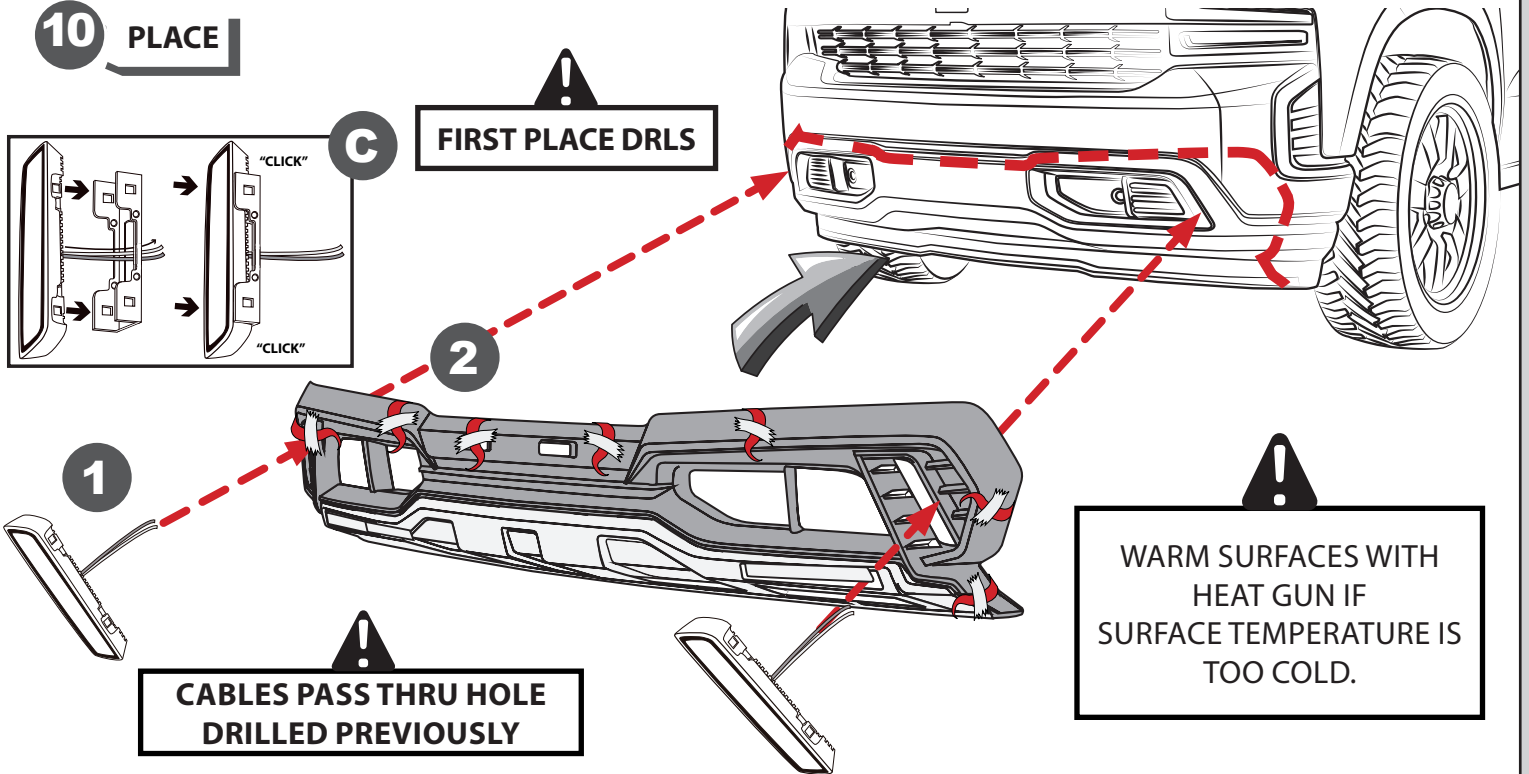

11 REMOVER LINER

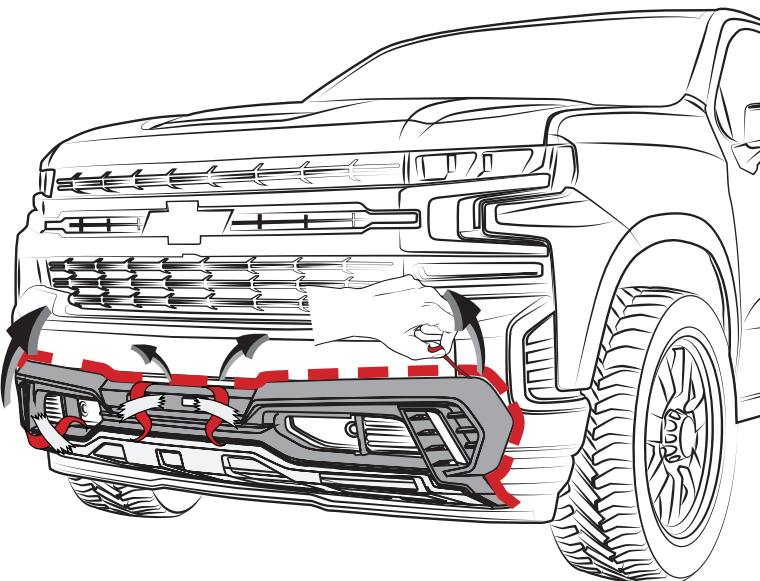

12 PRESS

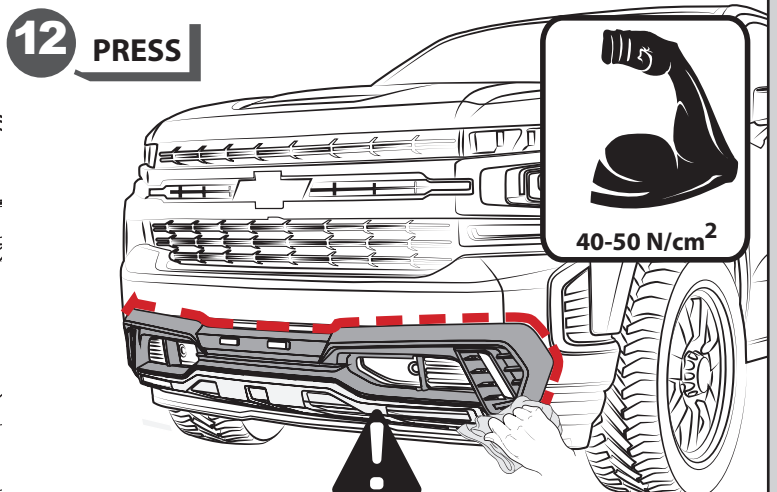

DURING APPLICATION, THE VEHICLE, ADD ON PARTS AND TAPE MUST BE AT OR ABOVE 16 °C OR 60 °F. A FULL SURFACE CONTACT BETWEEN TAPE AND SUBSTRATE IS IMPORTANT FOR GOOD ADHESION PERFORMANCE. CONTACT IS ACHIEVED BY APPLYING PRESSURE. IN PRACTICE A PRESSURE BETWEEN 40 AND 50 N/CM² IS USUALLY NEEDED.

INSTALLATION MANUAL

13 DRILL

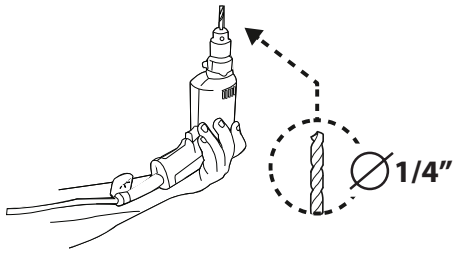
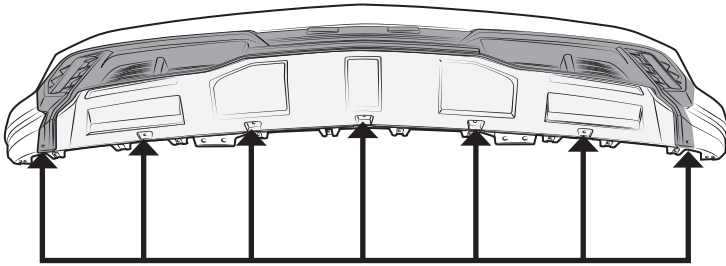

14 PLACE PUSH PINS

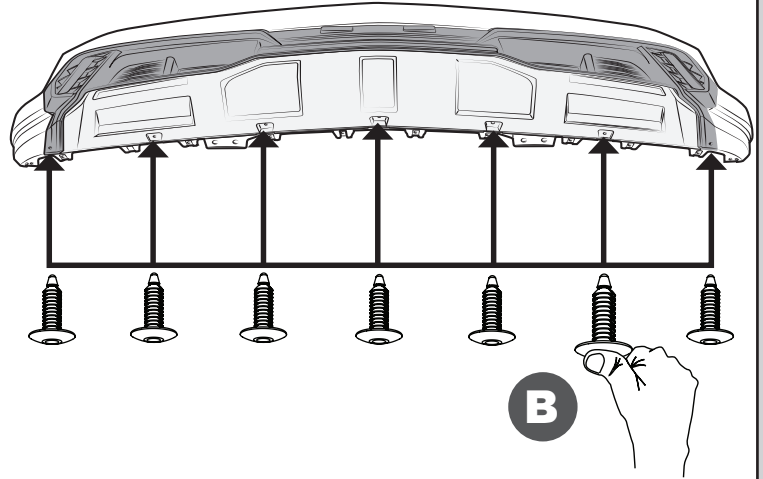

15 CONNECT CABLES TO CONTROL BOX

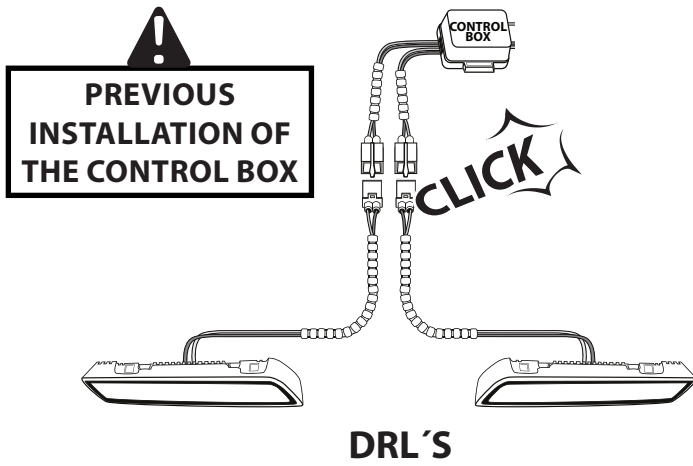

16 CLEAN OFF GREASE PENCIL MARK

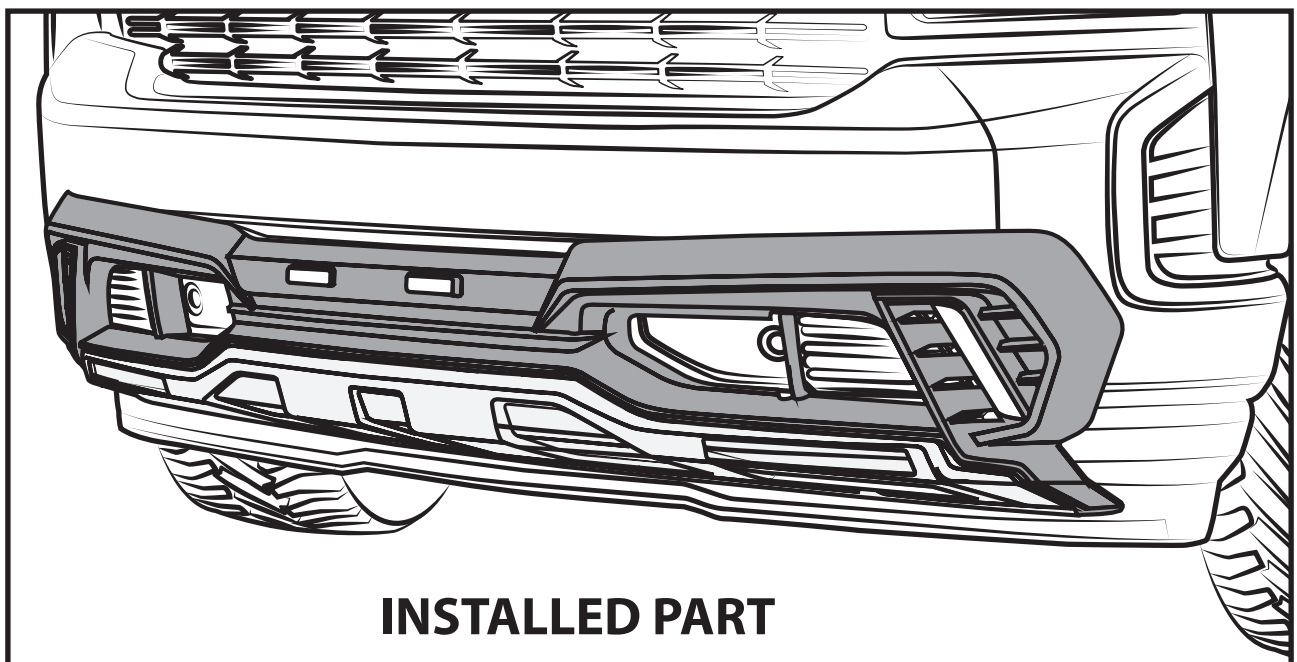
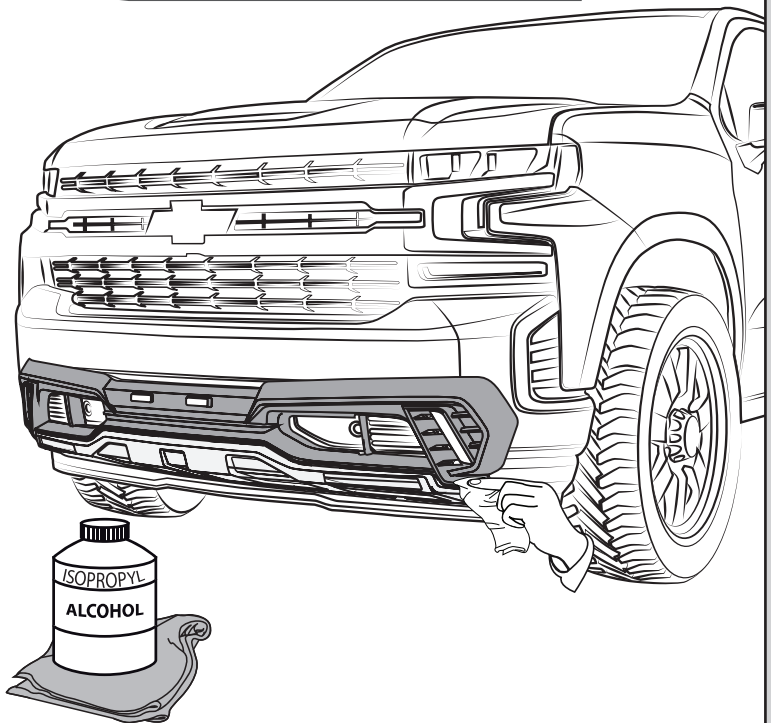

INSTALLED PART