

INSTALLATION MANUAL

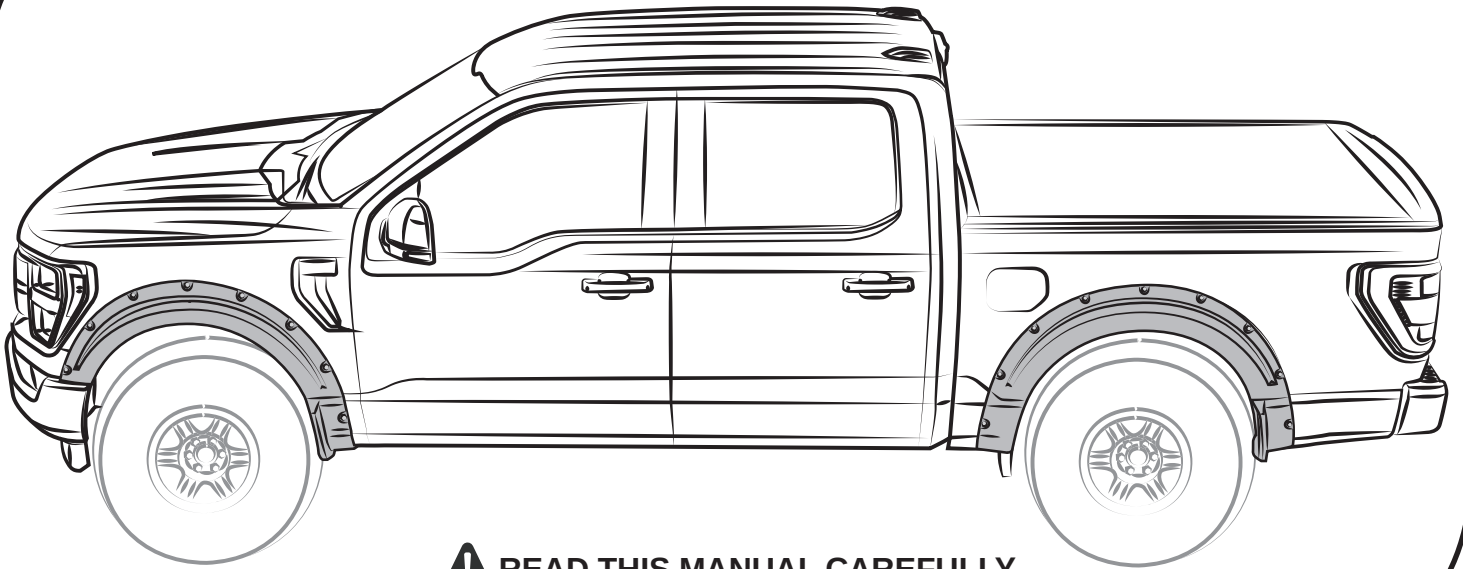

! READ THIS MANUAL CAREFULLY

SET NUMBER: FO31A16

BEFORE INSTALLING



WASH & CLEAN PROPERLY



WE RECOMMEND 2 PERSONS FOR INSTALLATION

AFTER INSTALLING



DO NOT WASH IN 48 HRS

TOOLS

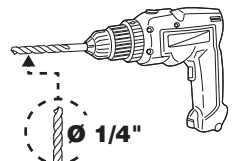
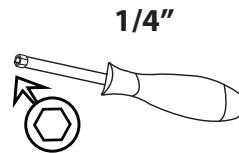
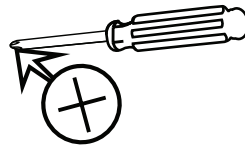

CHECK LIST

***ALREADY INSTALLED IN THE PART**

ITEM	DESCRIPTION	DRAWING	AMOUNT
A	*AIR DESIGN SUPER BOLT'S RUBBER STUDS		34 PCS
B	*STAINLESS AIR DESIGN SUPER BOLT 316.6 x 14.87 mm		34 PCS
C	*PVC PROFILE		29 FT
D	GREASE PENCIL		1 PC
E	APPLICATION SPONGE		1 PC
F	AUTOMOTIVE ADHESION PROMOTER TESA # 60153		1 PC
G	THREADLOCKER #3222		1 PC
H	AIR DESIGN SUPER BOLT PRESSER		1 PC
I	GRAPA WÜRTH 501 111 46		2 PCS
J	U04 U-CLIP		4 PCS
K	U05 U-CLIP		6 PCS
L	S-CLIP S01		8 PCS

AIR DESIGN SUPER BOLT FENDER FLARE SET

SET NUMBER: FO31A16



THE IDEAL TEMPERATURE RANGE OF THE PART AND THE VEHICLE WHEN INSTALLING MUST BE 16°C (60°F) TO 40°C (104°F), THIS GUARANTEES A CORRECT ASSEMBLY.

FRONT FENDER FLARE

1 REMOVE THE FACTORY FASTENERS & CLEAN



REMOVE ANY RINSE AID OR GLOSS ENHANCERS RESIDUE

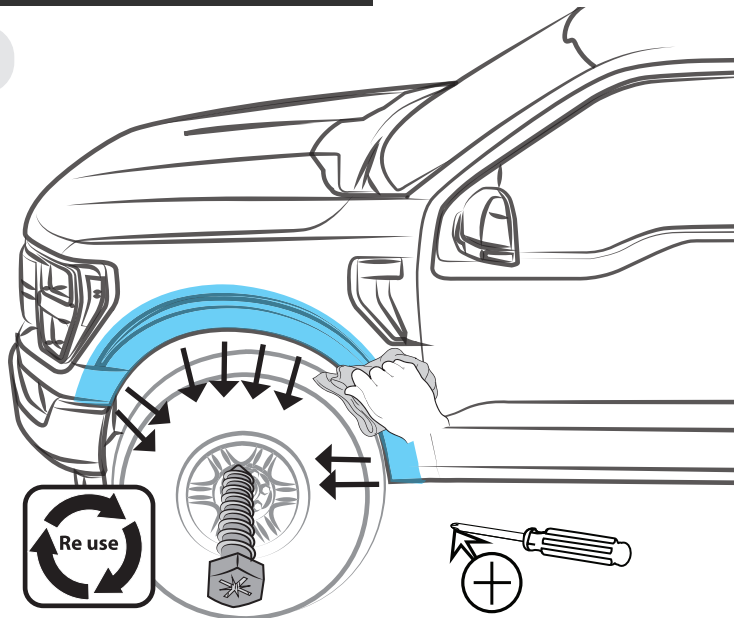

2 TEST FIT THE FENDER FLARE

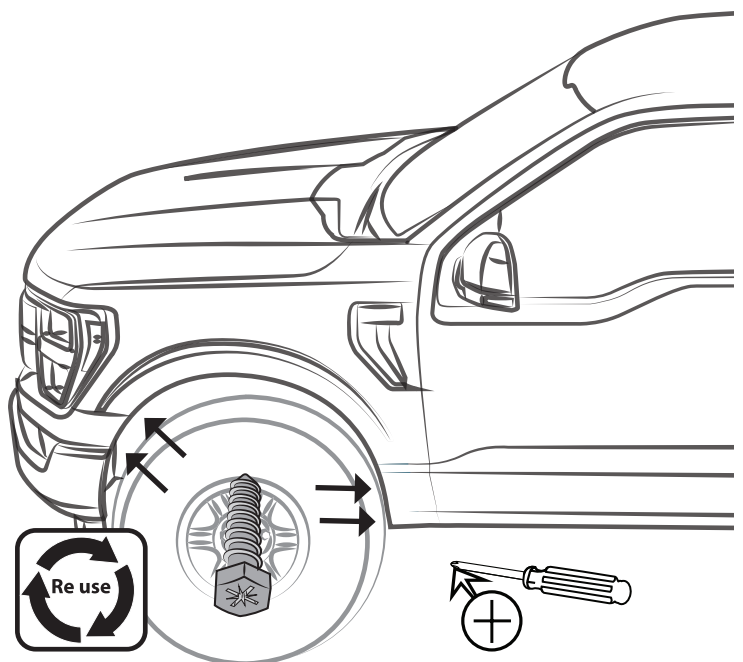
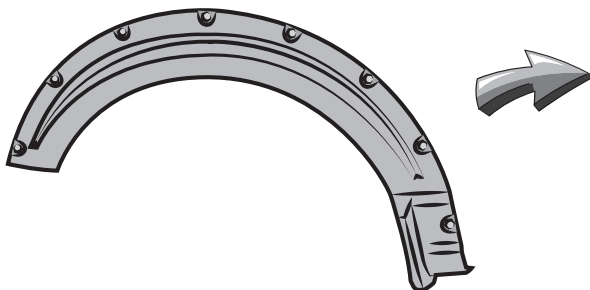

3 MARK



DRAW CENTER HASH MARK WITH GREASE PENCIL ON EACH AIR DESIGN SUPER BOLT AND SHEET METAL. THIS WILL ENSURE FENDER FLARE WILL BE CENTERED TO GREASE PENCIL OUTLINE.



APPLY PRESSURE TO THE WHEEL ARCH

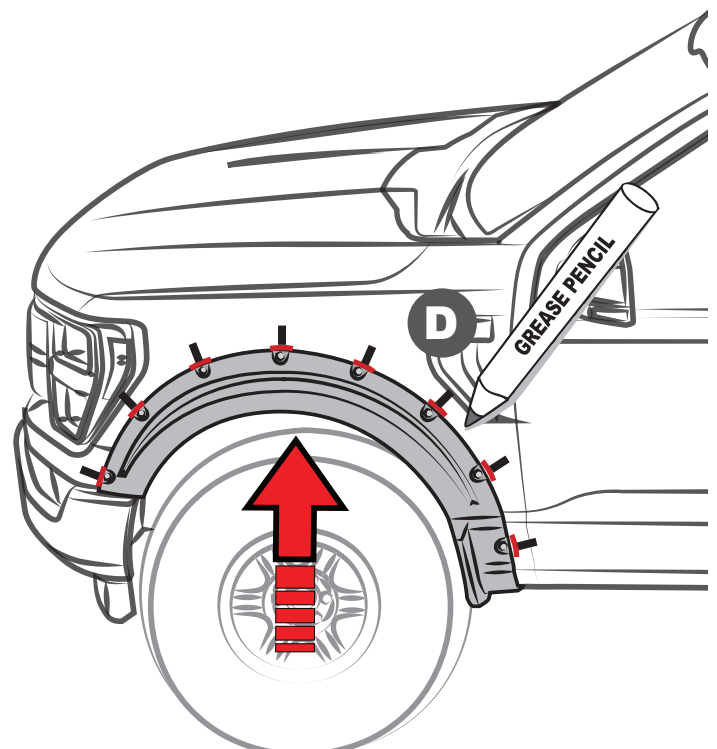

4 REMOVE THE FENDER FLARE

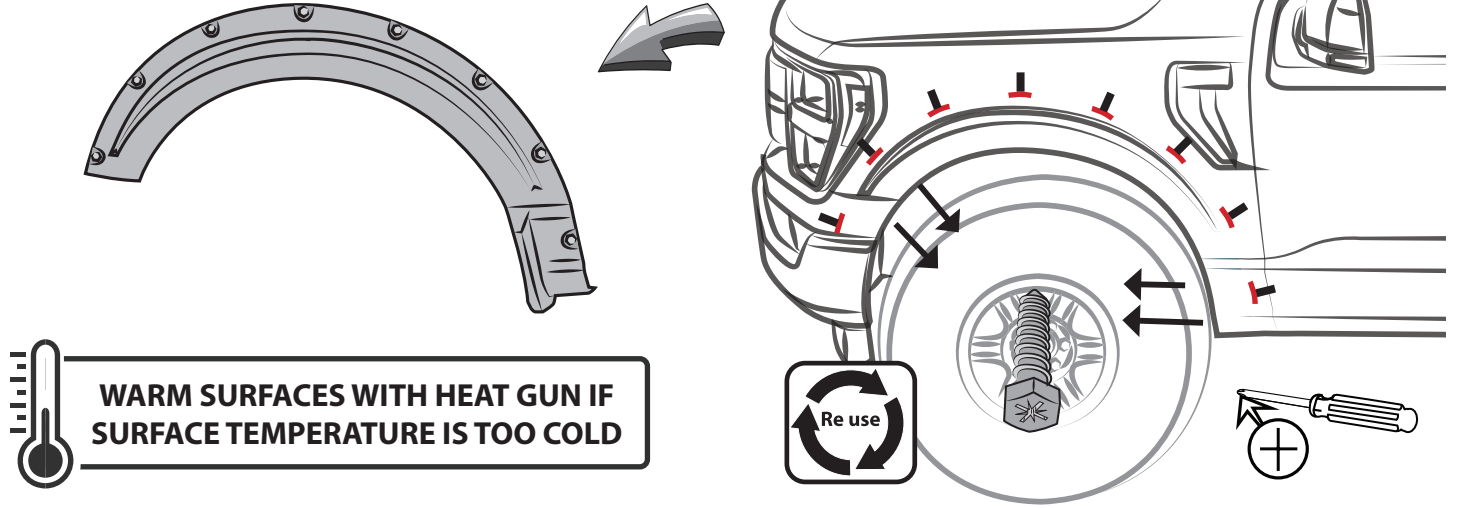

5 APPLY THE ADHESION PROMOTER TESA

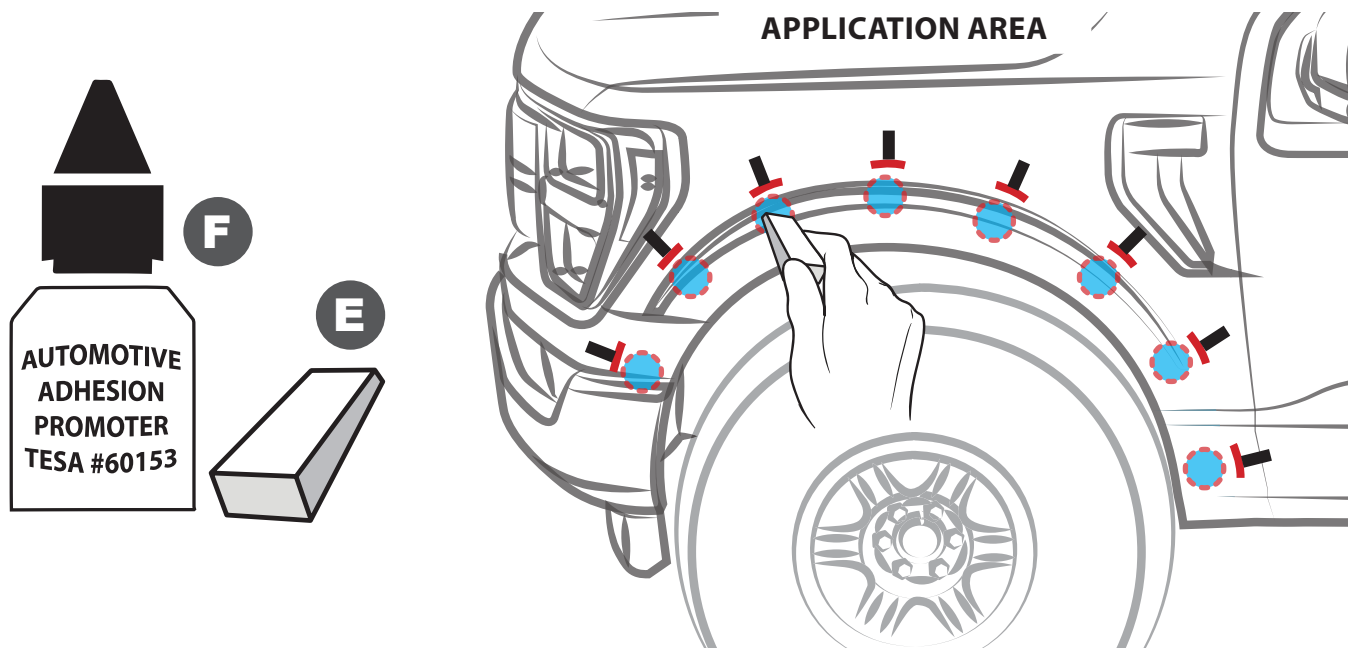

6 REMOVE THE BLUE ADHESIVE TAPE

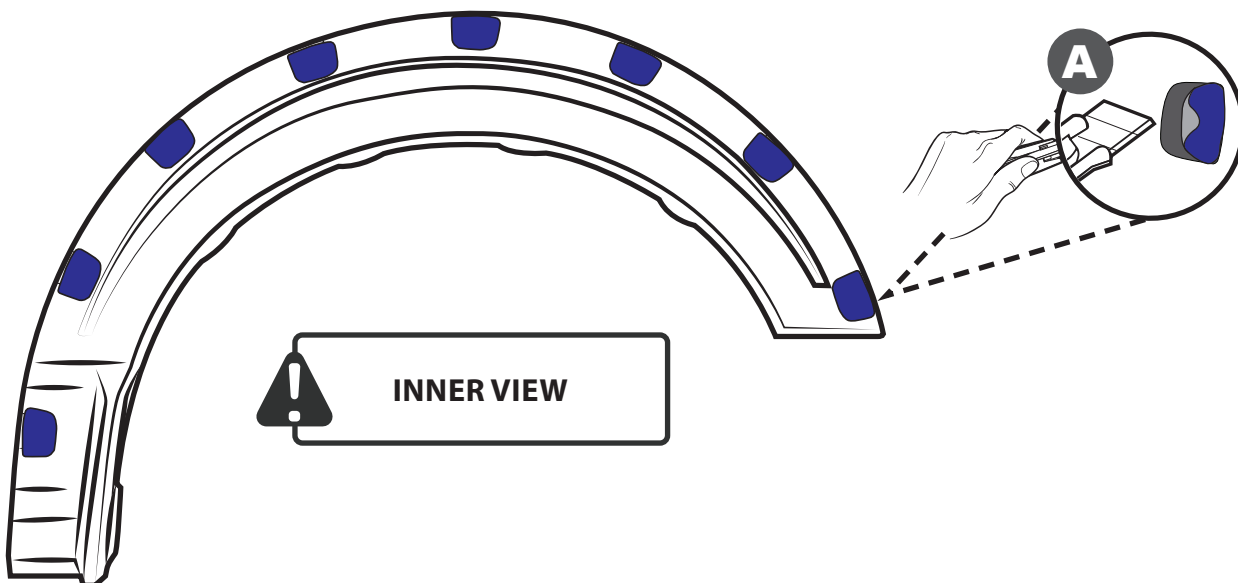

AIR DESIGN SUPER BOLT FENDER FLARE SET

SET NUMBER: FO31A16

7 PLACE AND SECURE

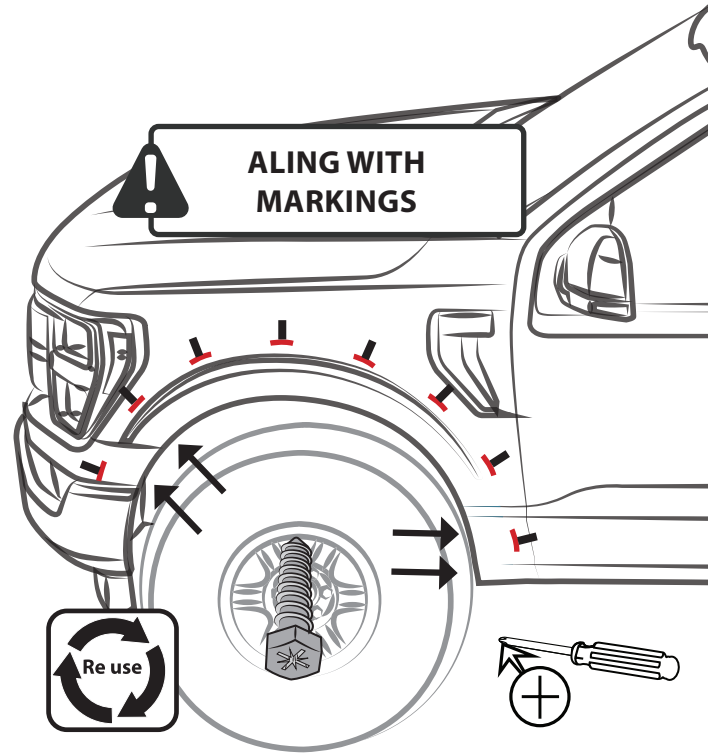
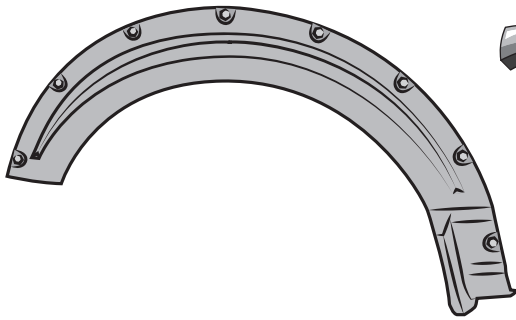

8 PRESS FIRMLY

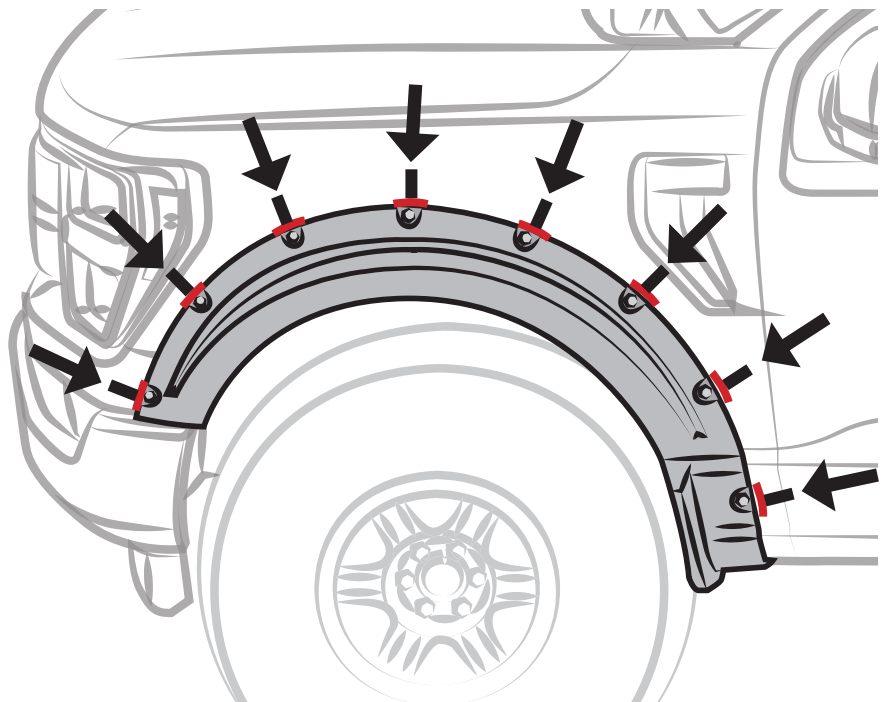
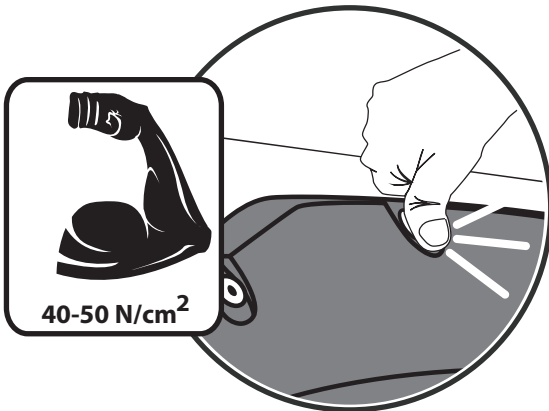

9 REMOVE AIR DESIGN SUPER BOLTS

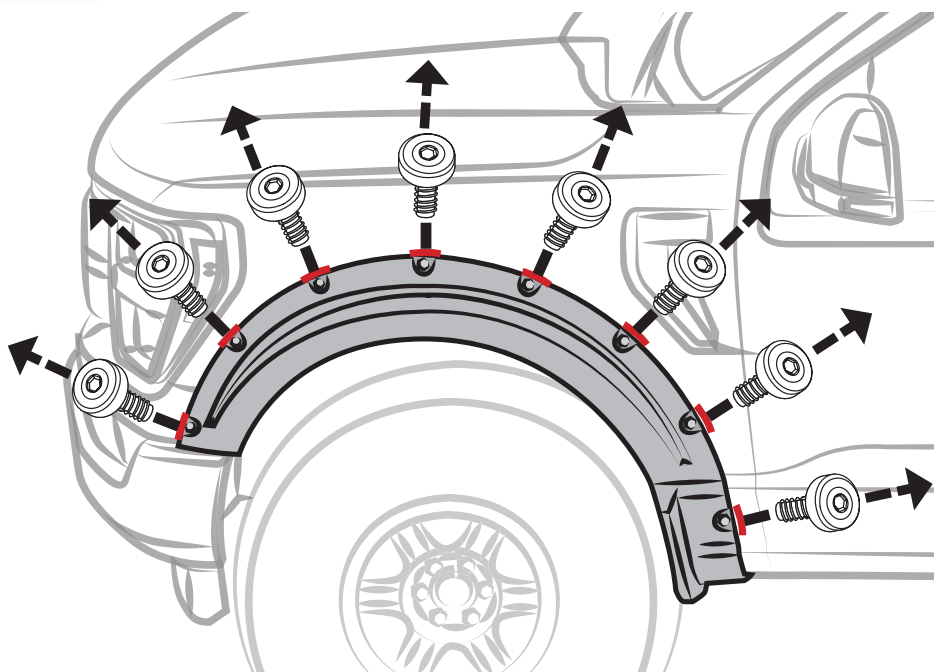
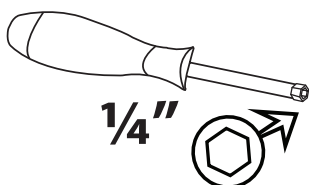

10 REMOVE THE FENDER FLARE

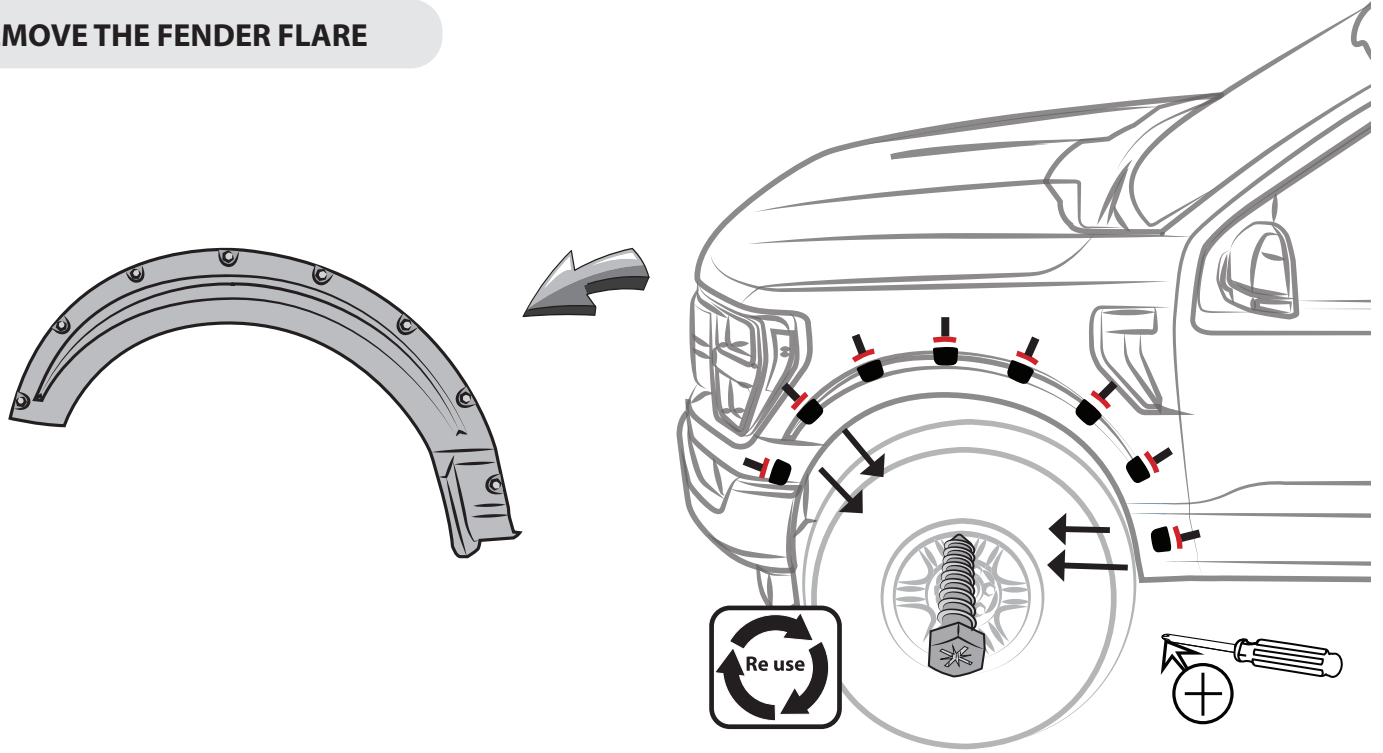

11 AIR DESIGN SUPER BOLT'S STUDS INSTALLATION

ATTENTION

FOR GOOD ADHESION IS NECESSARY TO APPLY AS MUCH PRESSURE AS POSSIBLE ALL OVER THE EDGE AND CENTER OF THE AIR DESIGN SUPER BOLT'S STUDS.

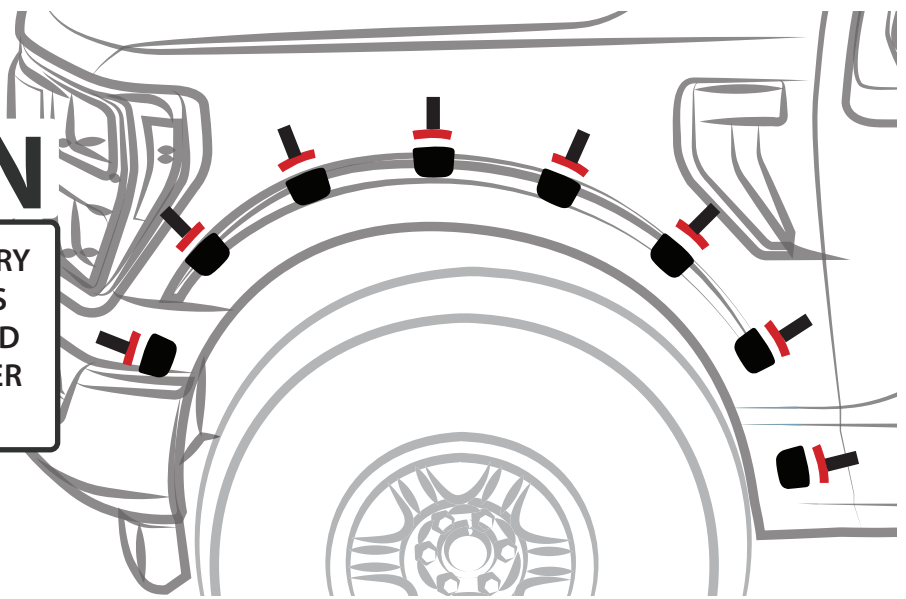

PRESSURE POINTS

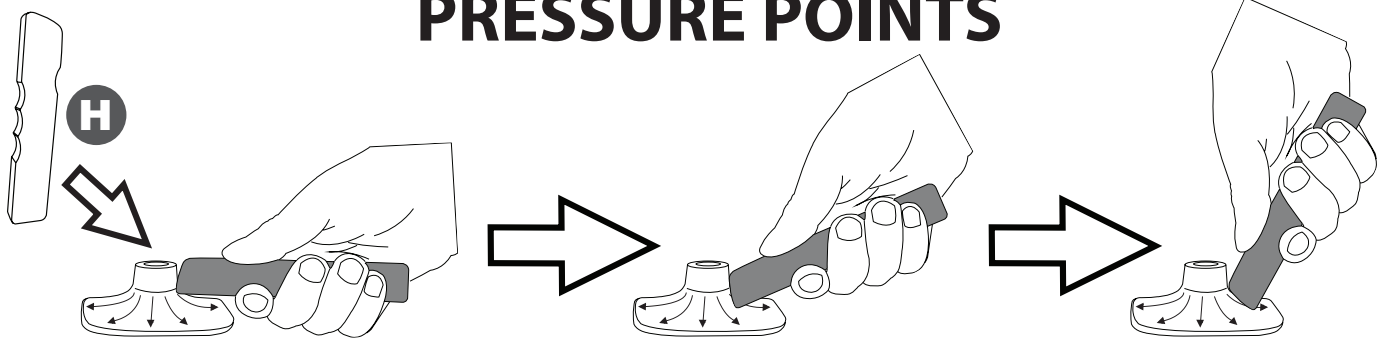

! IMPORTANT

A full surface contact between tape and substrate is decisive for good adhesion performance.

Contact is achieved by applying pressure. In practice a pressure between 40 and 50 N/

cm² is usually needed and an application temperature between 25 and 45 °C or 77 and 113 °F is also necessary.

During application, add-on parts and tapes must have the similar temperature.

AIR DESIGN SUPER BOLT FENDER FLARE SET

SET NUMBER: FO31A16

12 PLACE THE FENDER FLARE

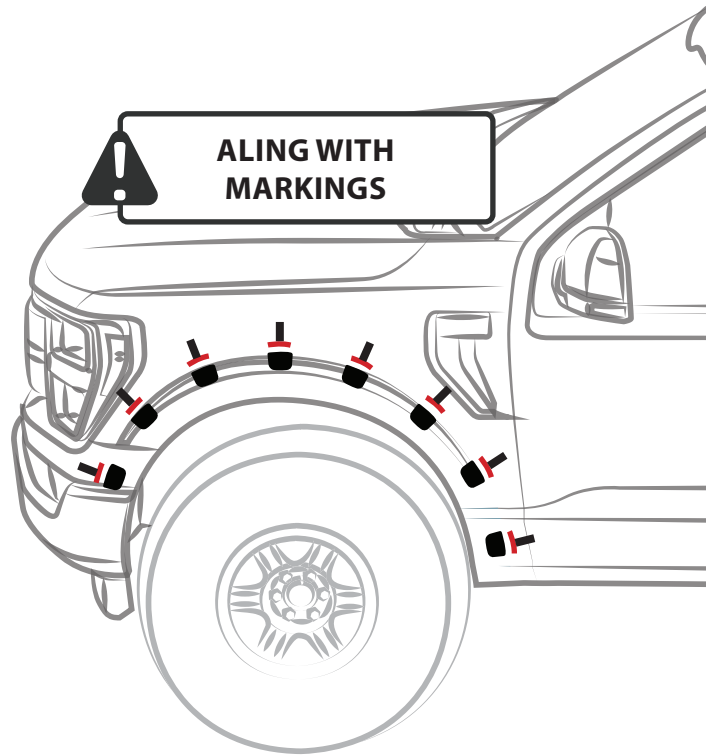
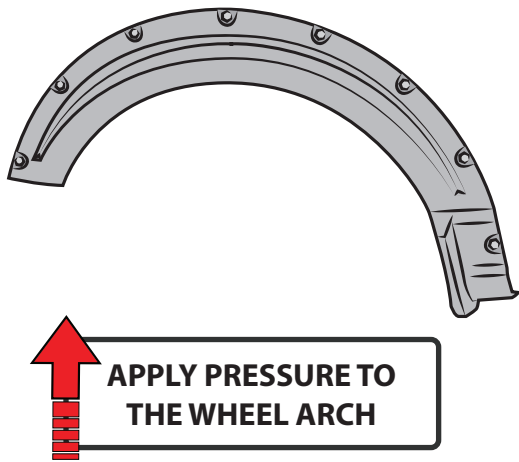

13 PLACE AIR DESIGN SUPER BOLTS

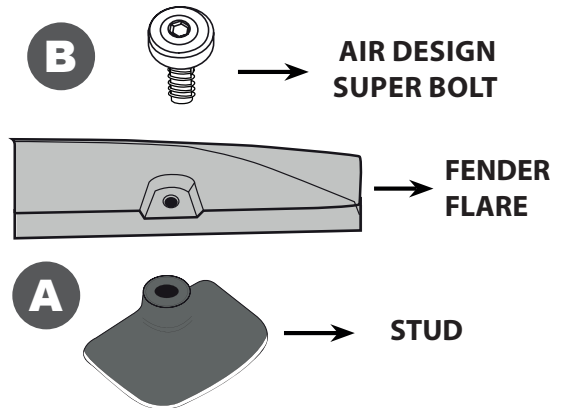
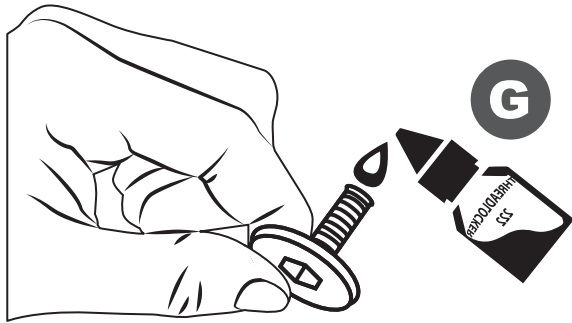

! APPLY THREAD LOCKER TO EACH AIR DESIGN SUPER BOLT

! HAND TIGHT

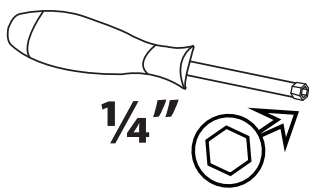

! DON'T FORCE IT ONCE IT HAS STOPPED

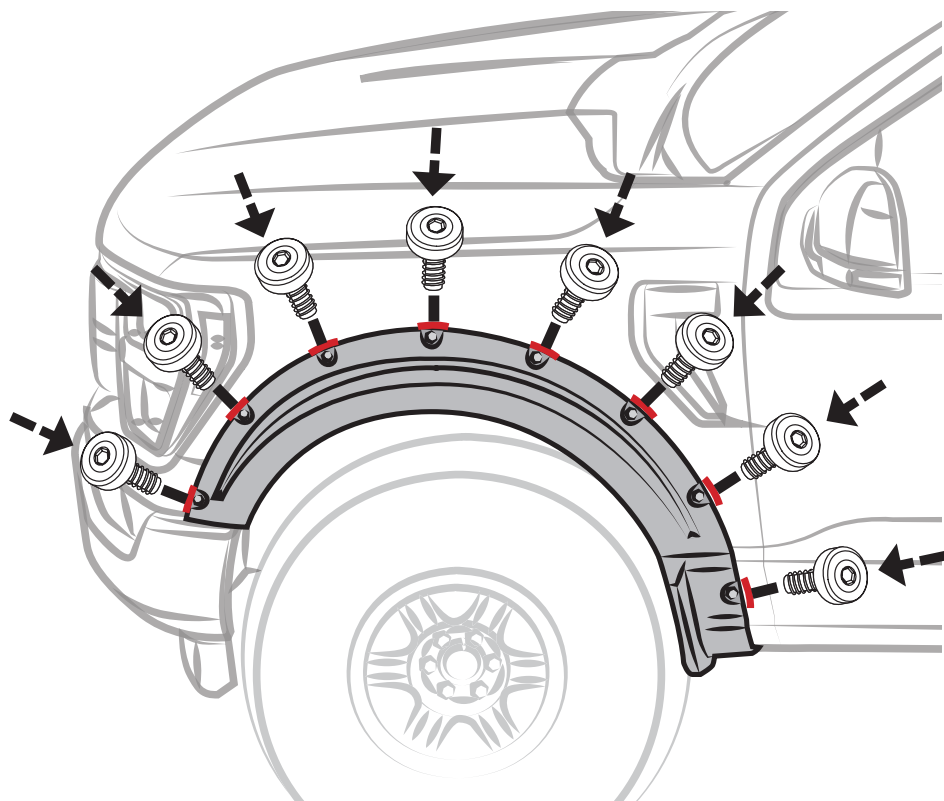

14 SECURE THE FENDER FLARE

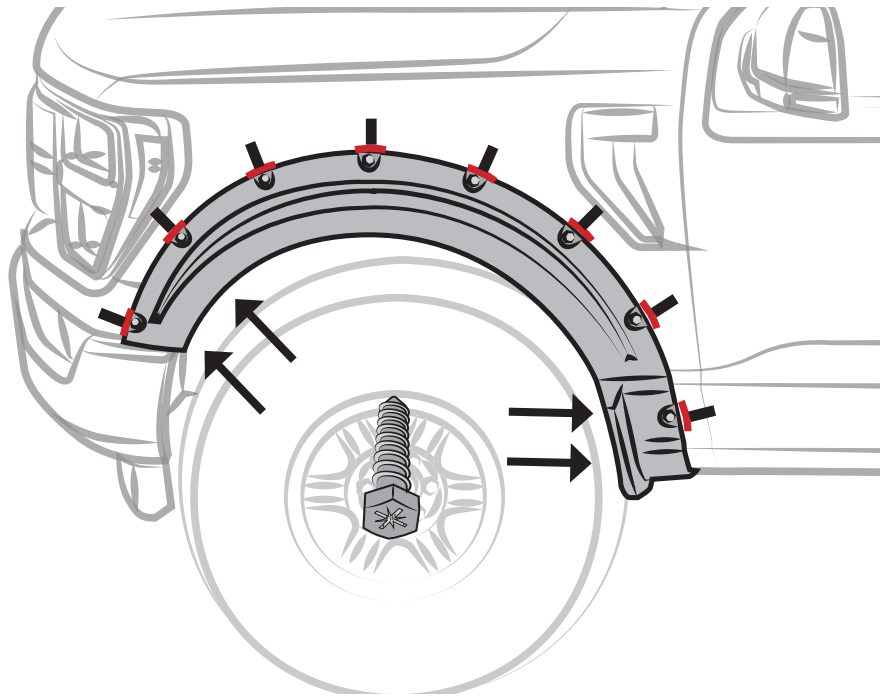
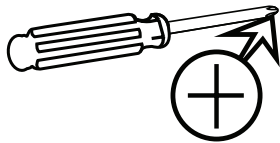

15 DRILL

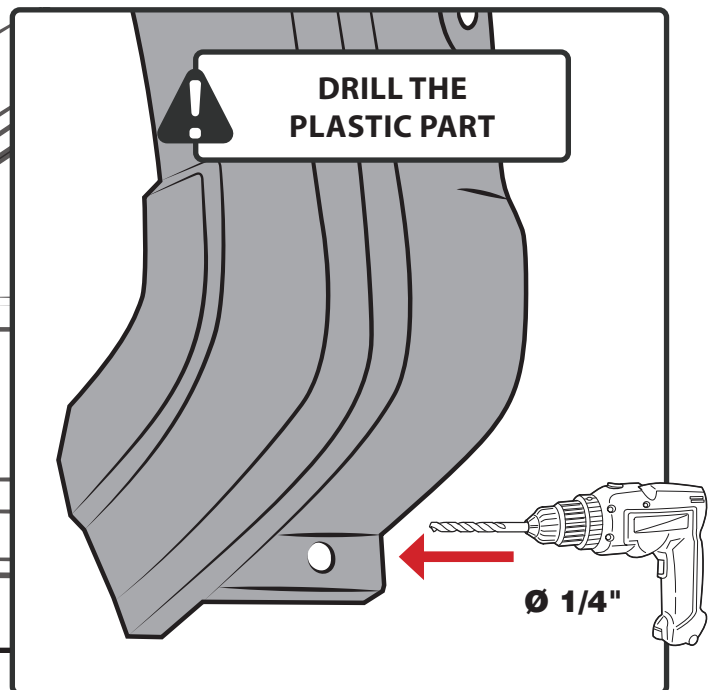
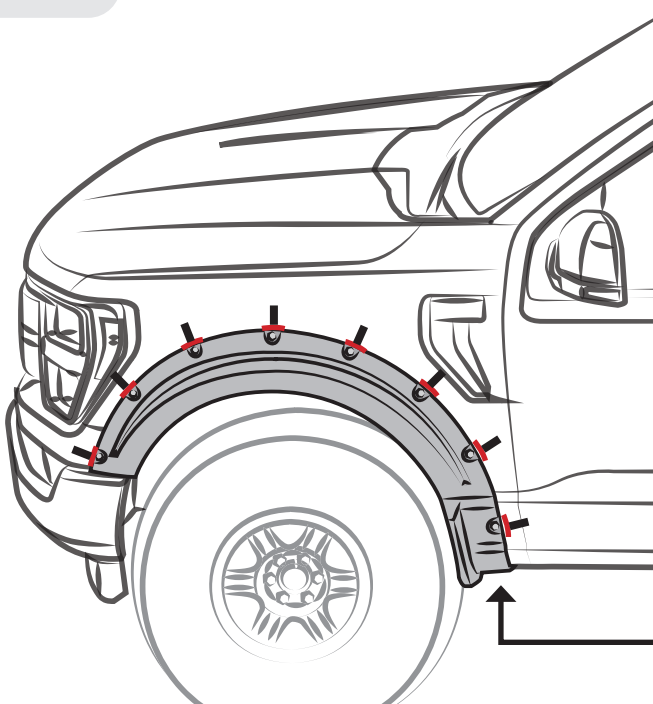

16 PLACE PUSH PIN

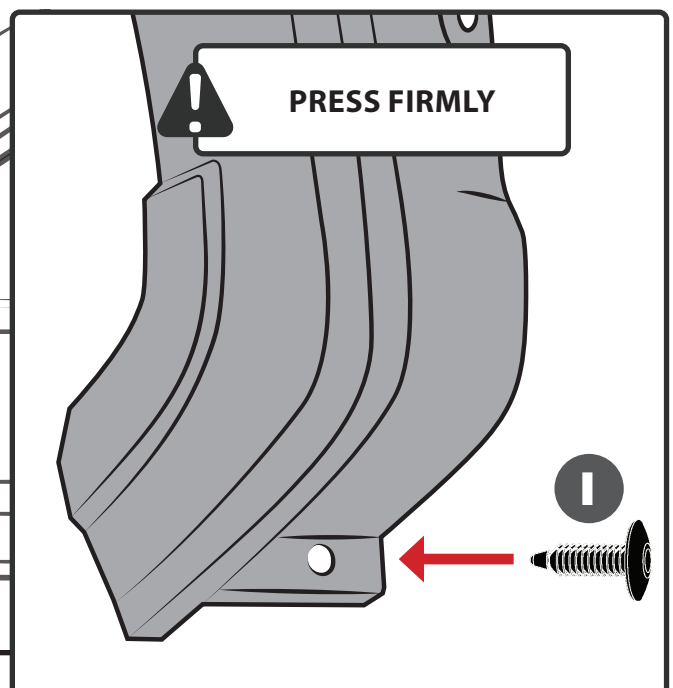
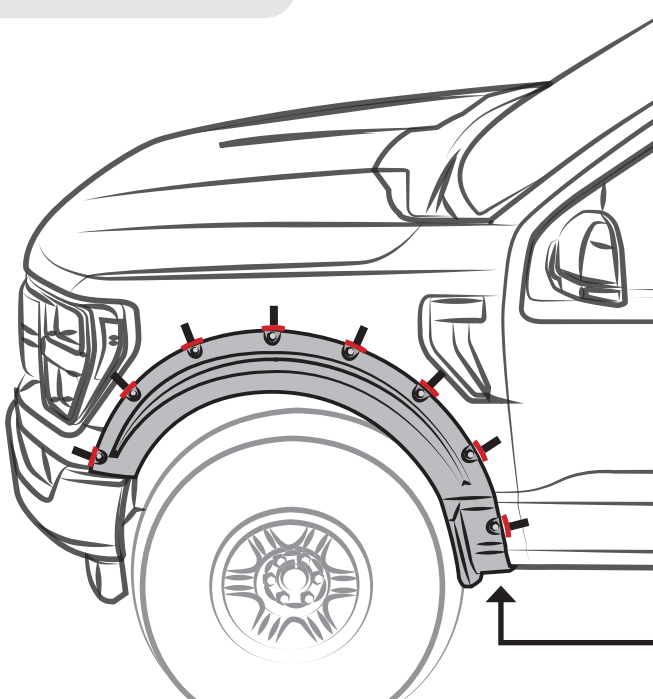

AIR DESIGN SUPER BOLT FENDER FLARE SET

SET NUMBER: FO31A16

17 PLACE THE S-CLIP S01 AND SECURE

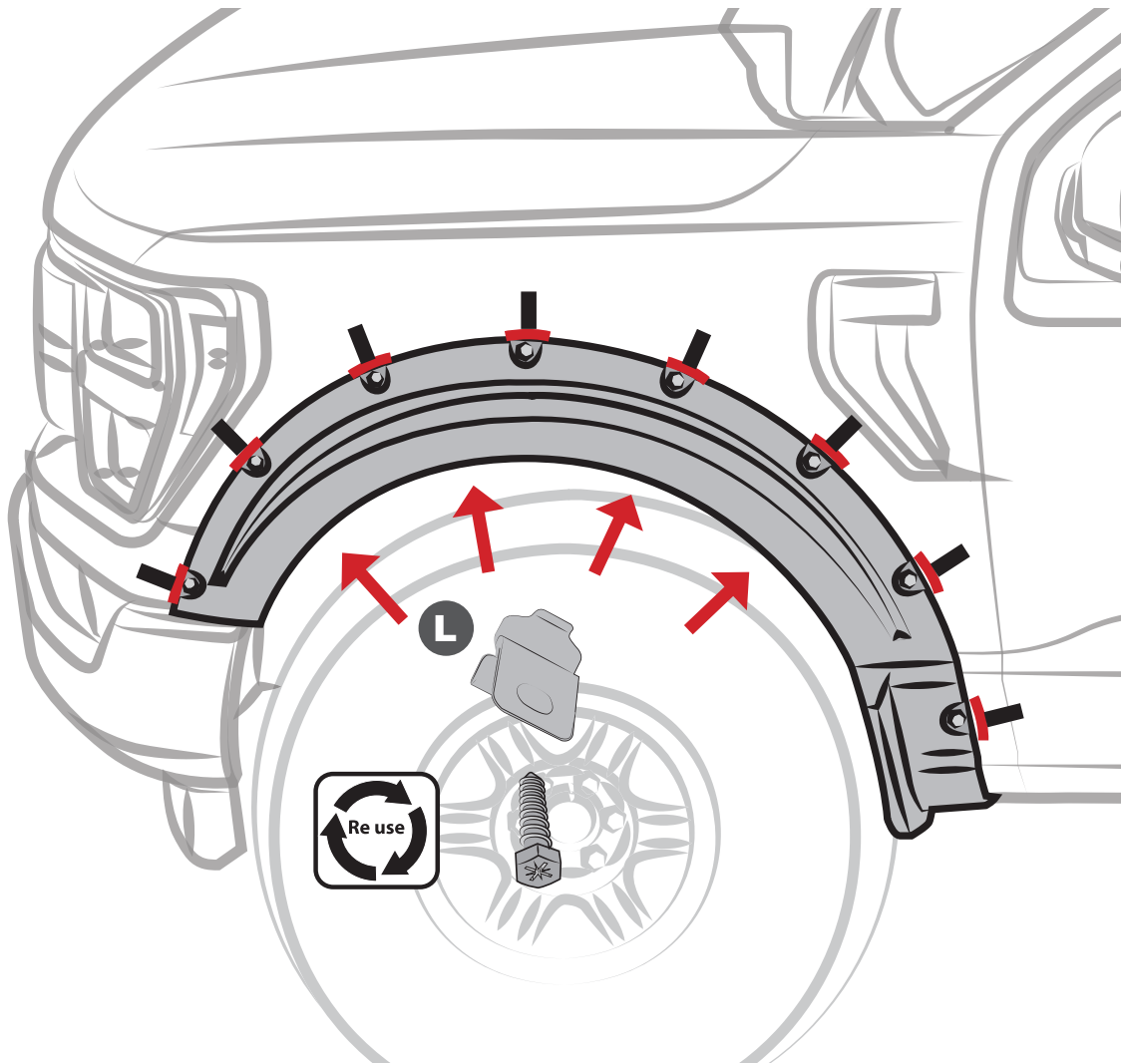

17 CLEAN OFF THE MARKINGS



REPEAT ALL STEPS FOR RH SIDE

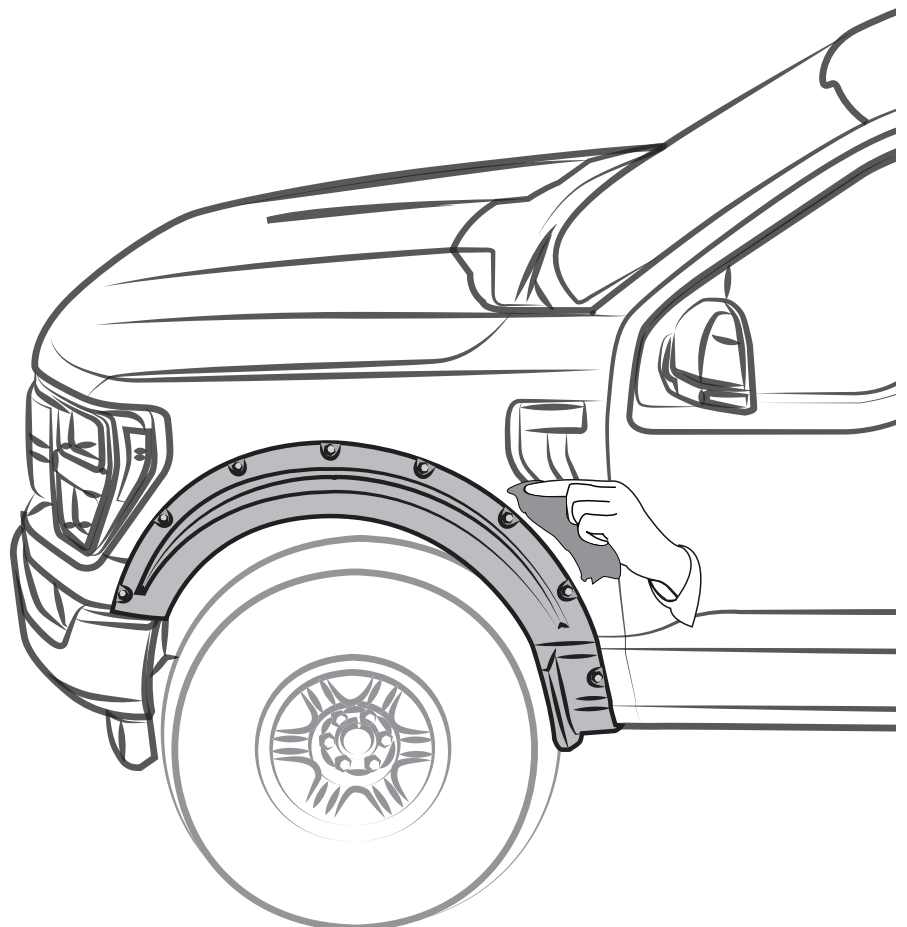



THE IDEAL TEMPERATURE RANGE OF THE PART AND THE VEHICLE WHEN INSTALLING MUST BE 16°C (60°F) TO 40°C (104°F), THIS GUARANTEES A CORRECT ASSEMBLY.

REAR FENDER FLARE

1 REMOVE FACTORY FASTENERS

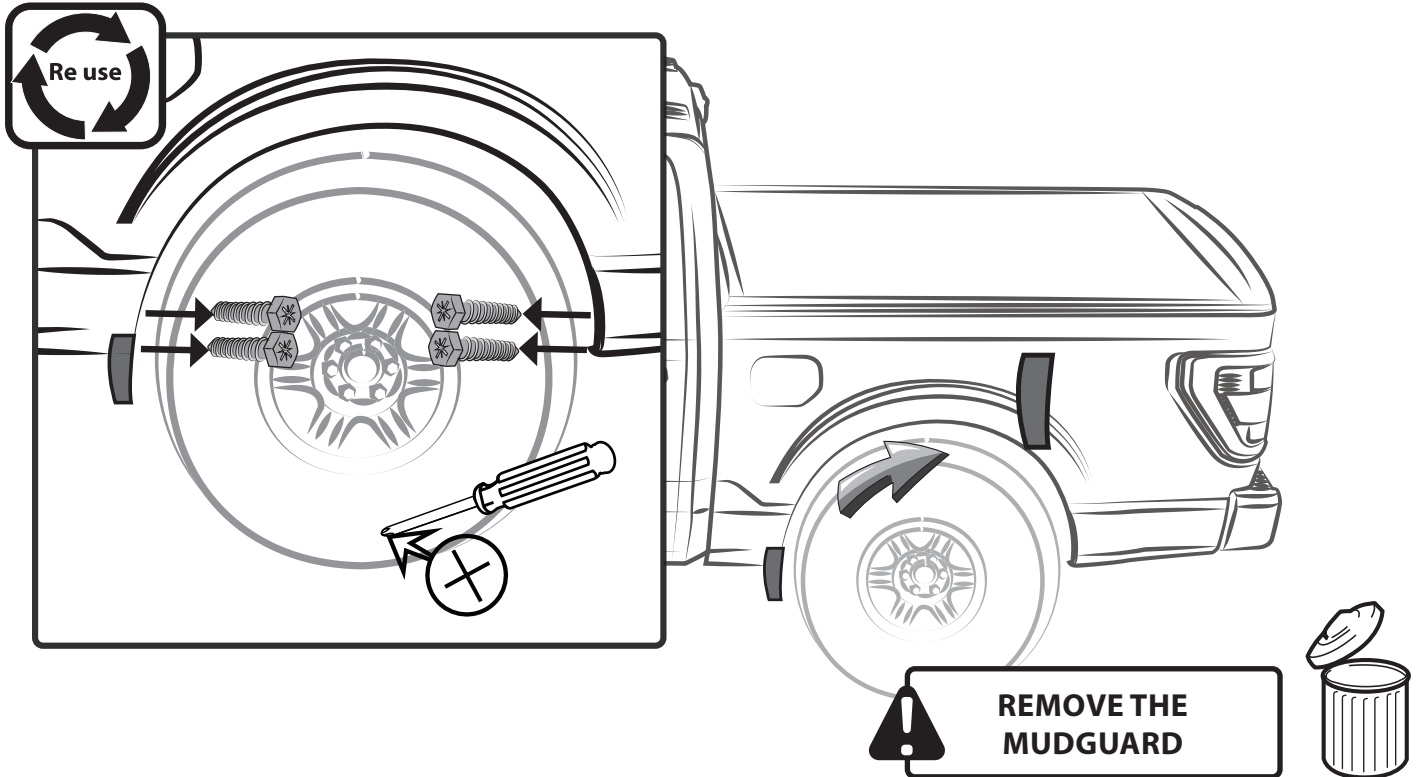

2 CLEAN THE INSTALLATION ZONE

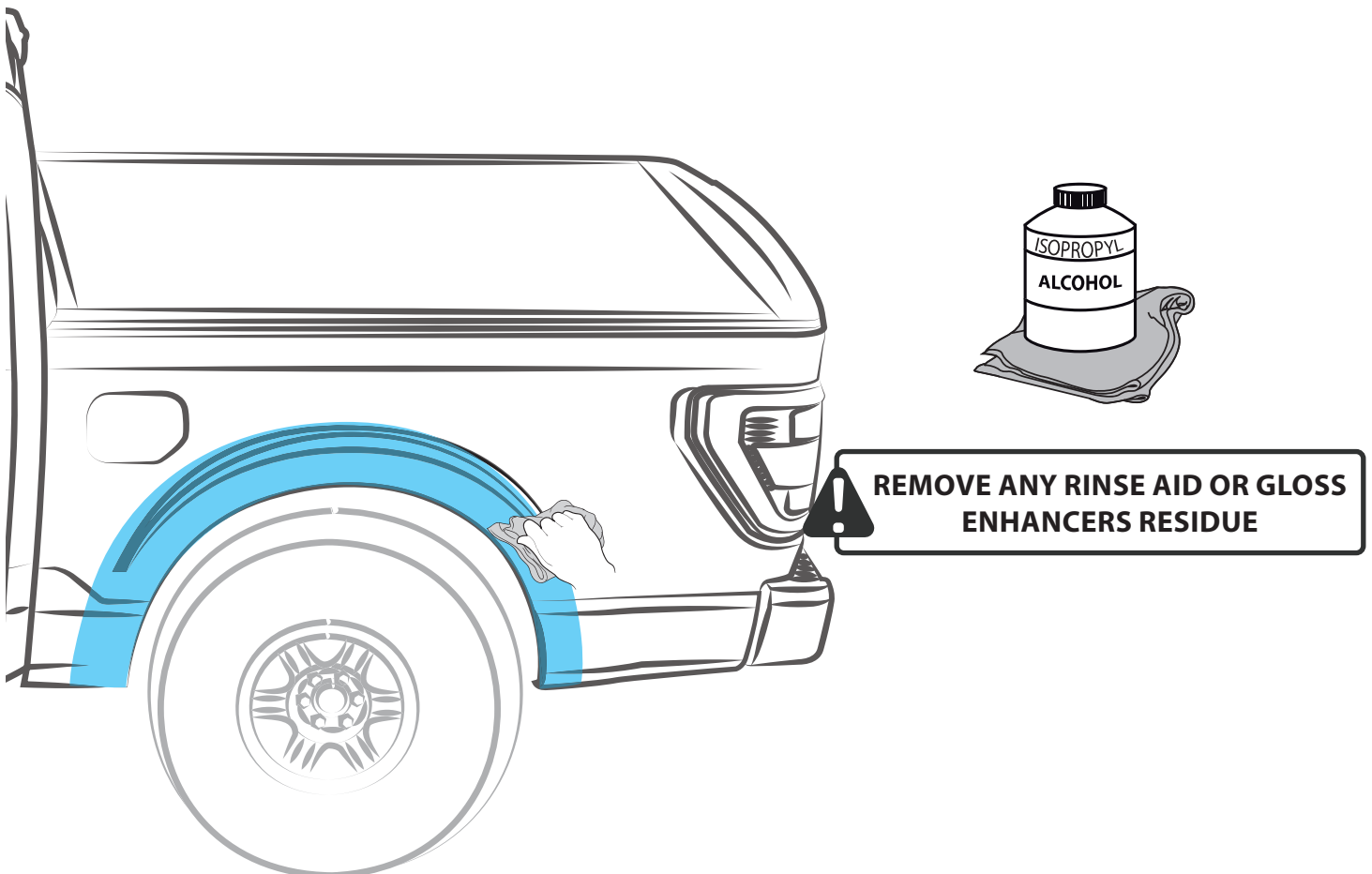

AIR DESIGN SUPER BOLT FENDER FLARE SET

SET NUMBER: FO31A16

3 TEST FIT THE FENDER FLARE

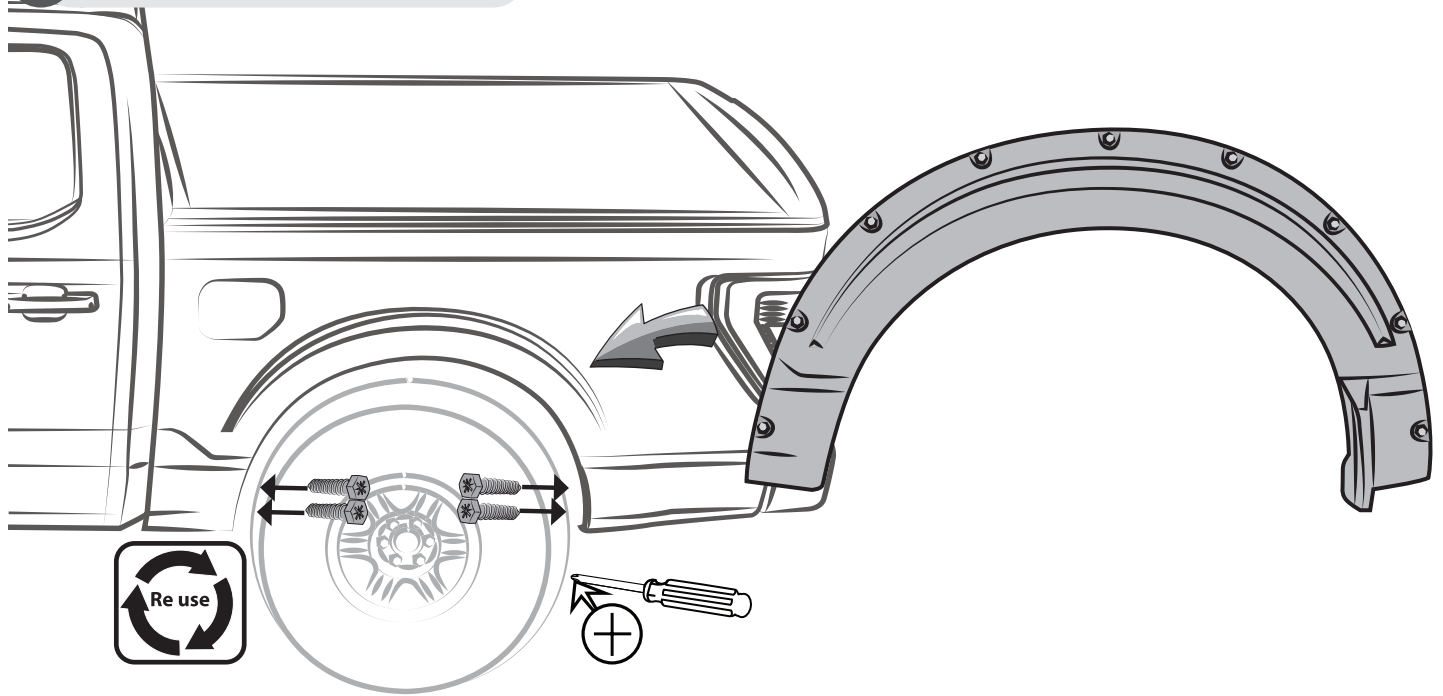

4 MARK

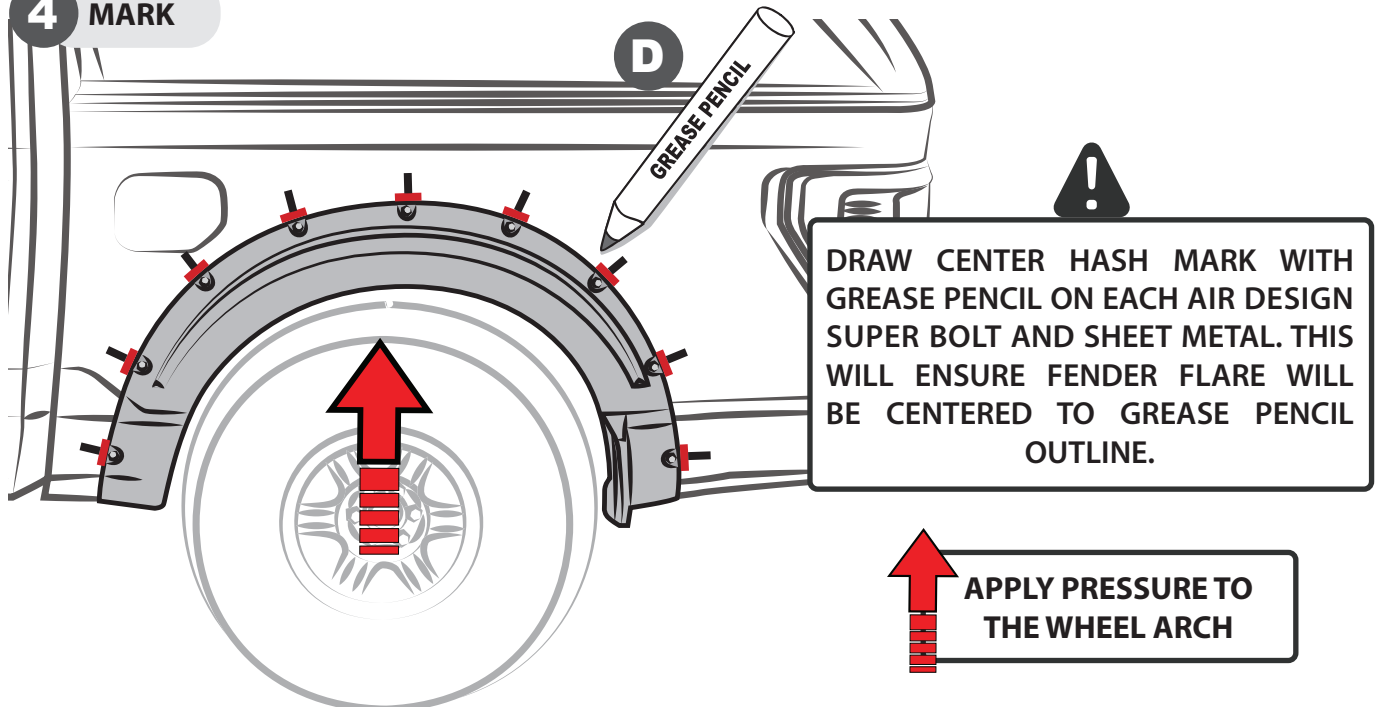

5 REMOVE THE FENDER FLARE

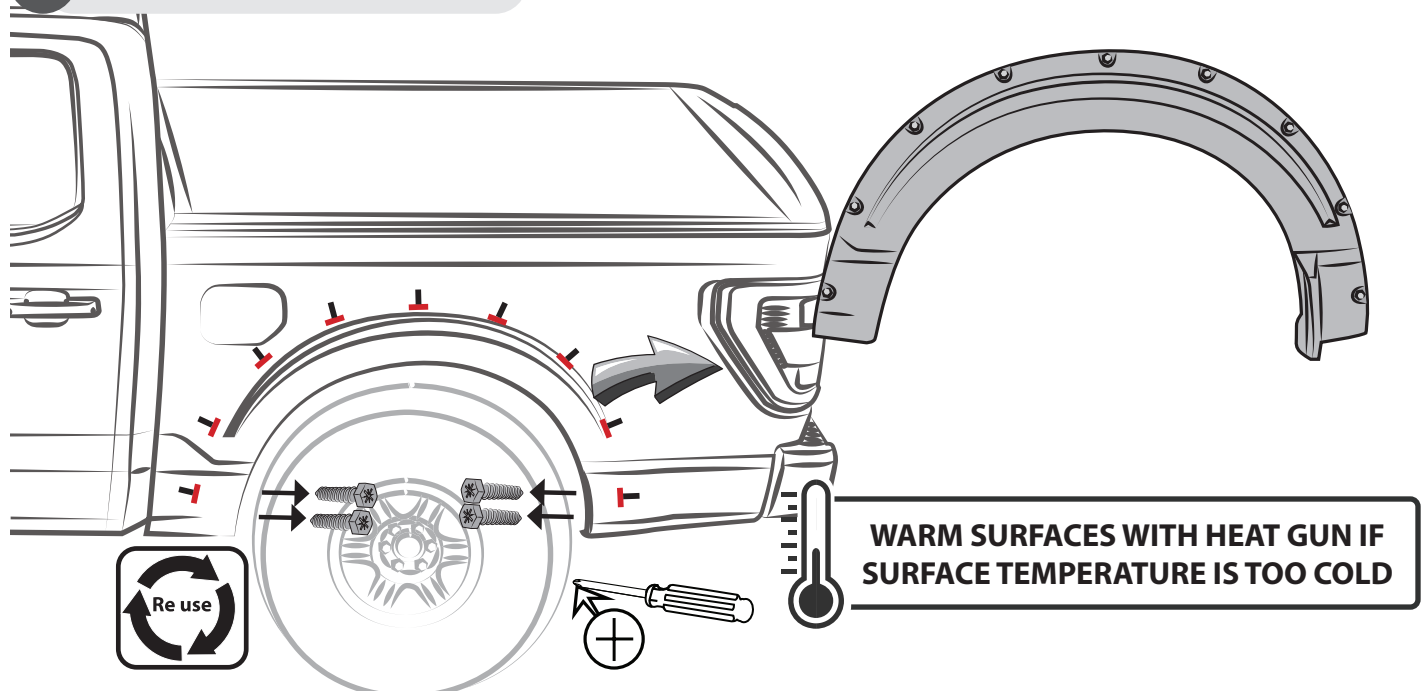

6 APPLY THE ADHESION PROMOTER TESA

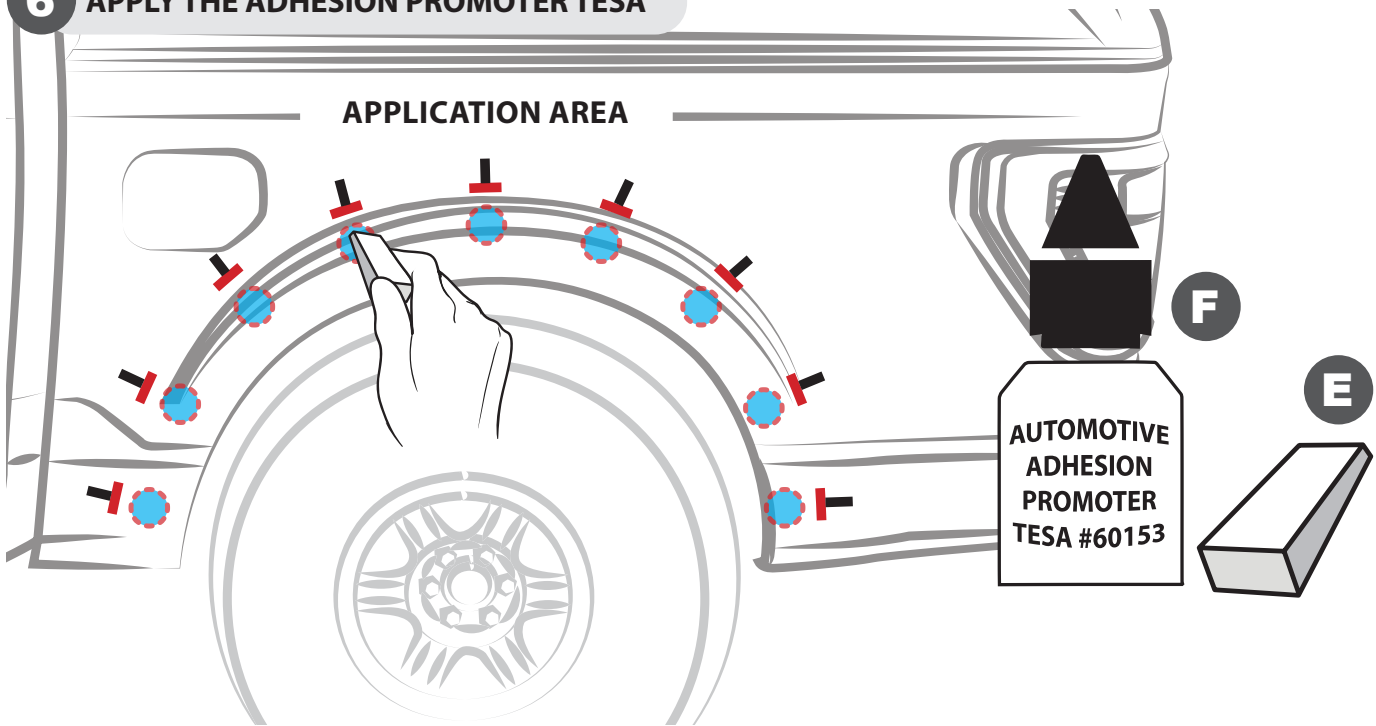

7 REMOVE THE BLUE ADHESIVE TAPE

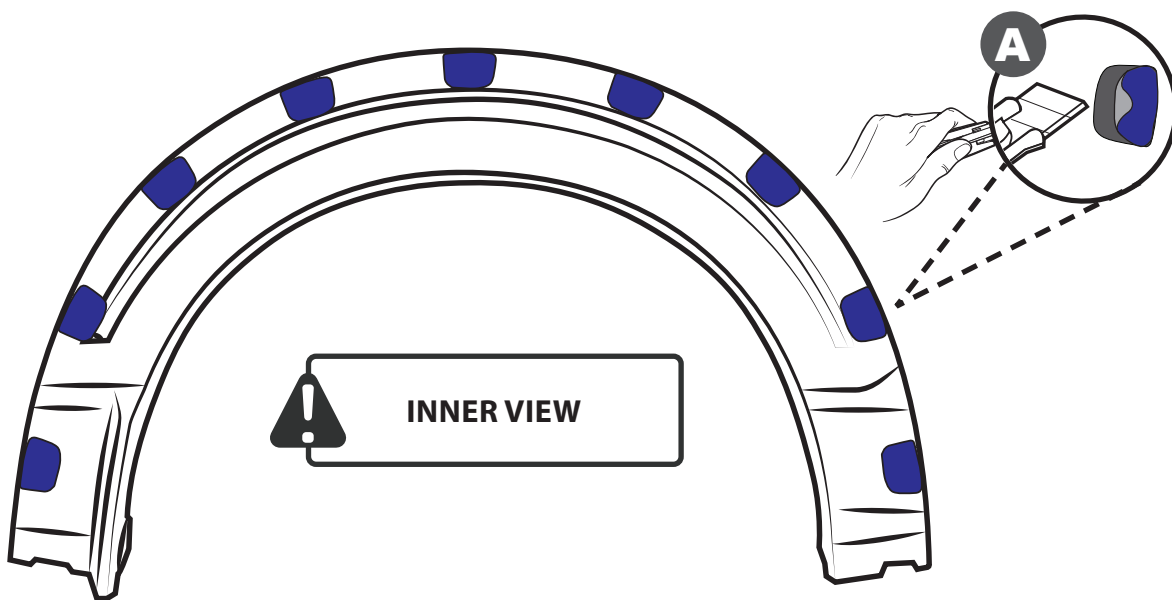

8 PLACE AND SECURE

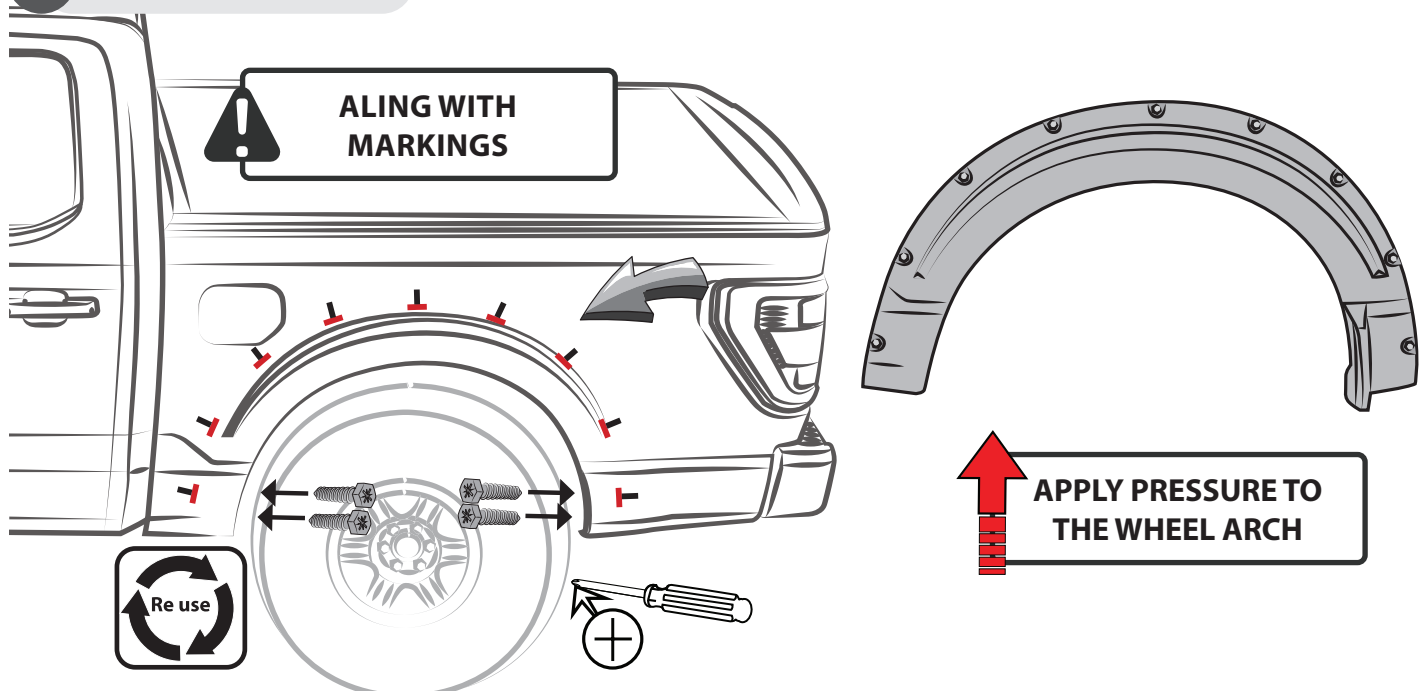

AIR DESIGN SUPER BOLT FENDER FLARE SET

SET NUMBER: FO31A16

9 PRESS FIRMLY

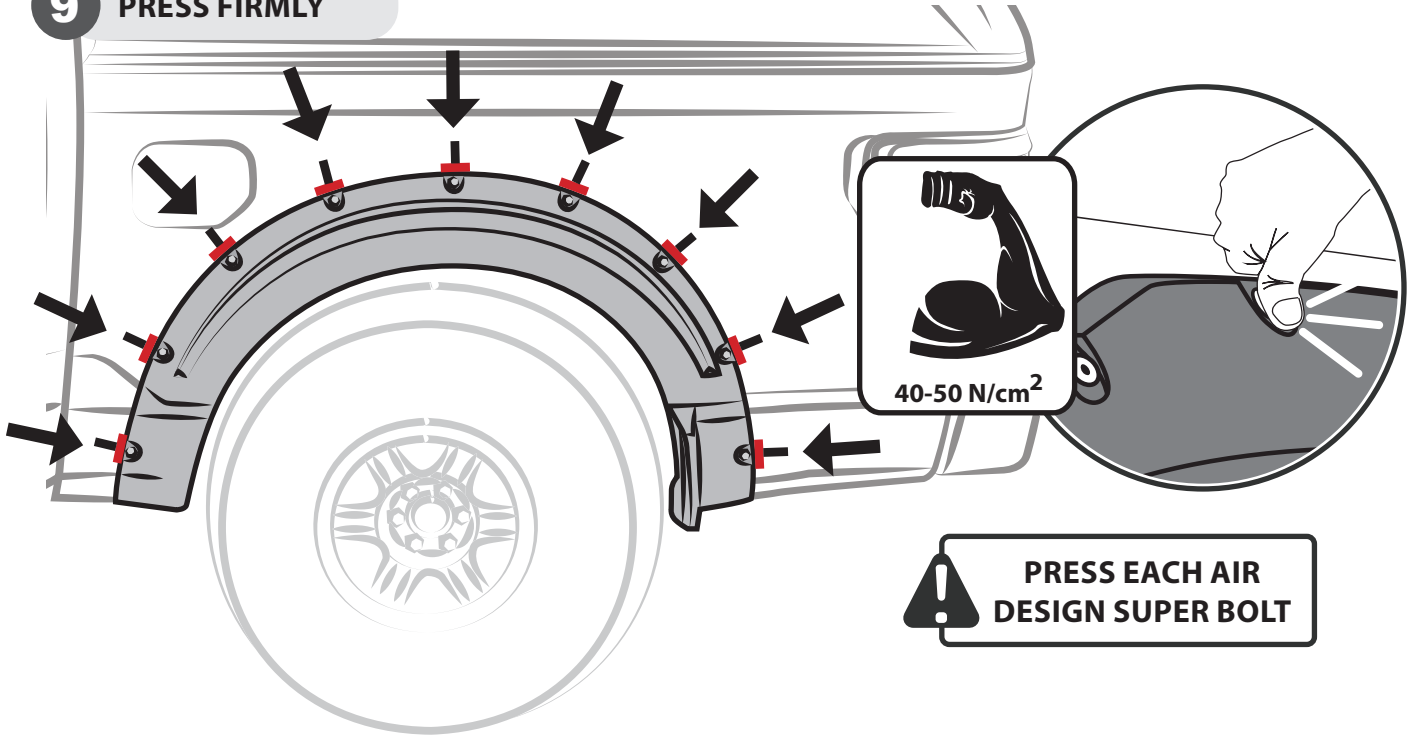

10 REMOVE AIR DESIGN SUPER BOLT

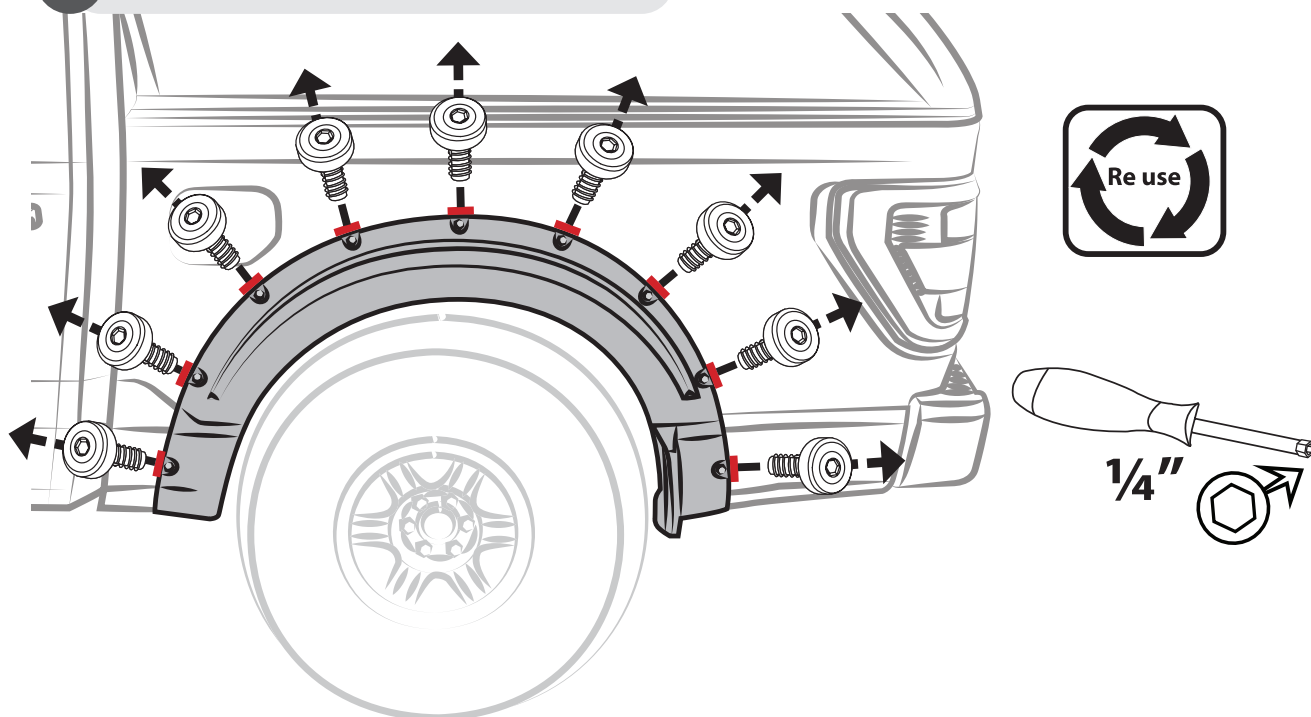

11 REMOVE THE FENDER FLARE

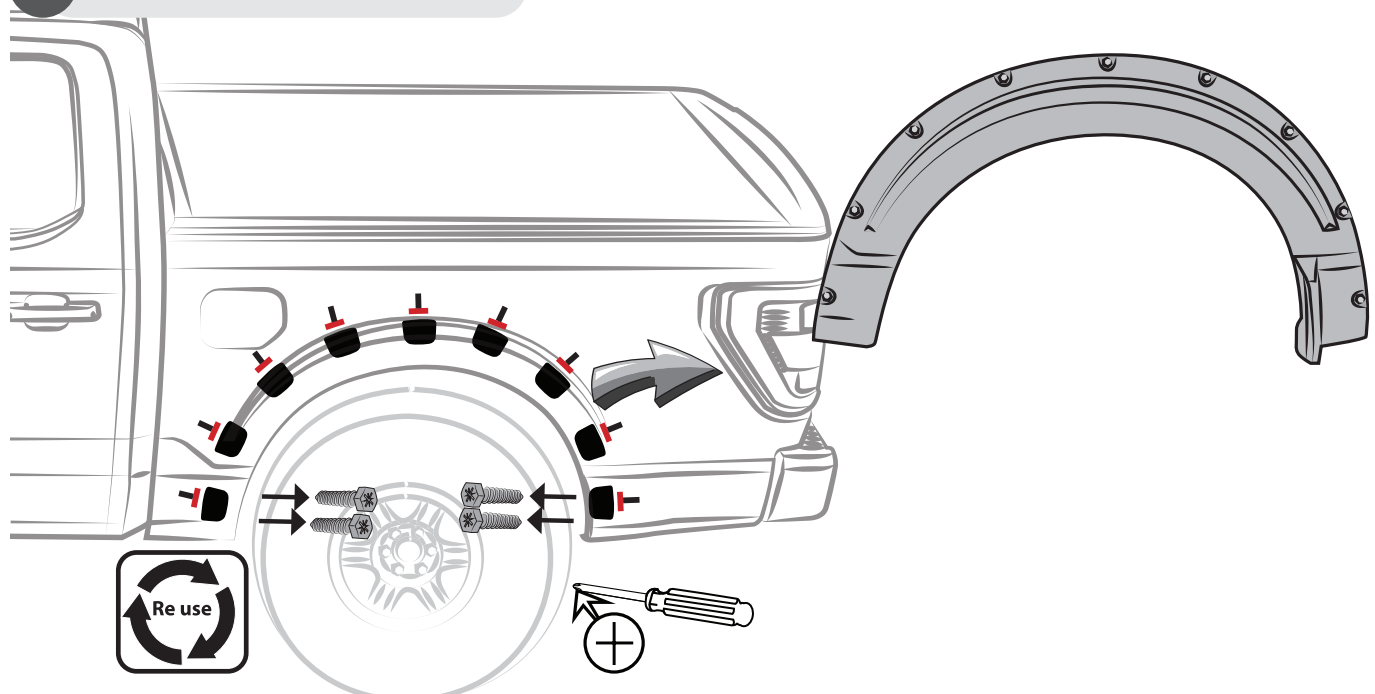

11 AIR DESIGN SUPER BOLT'S STUDS INSTALLATION

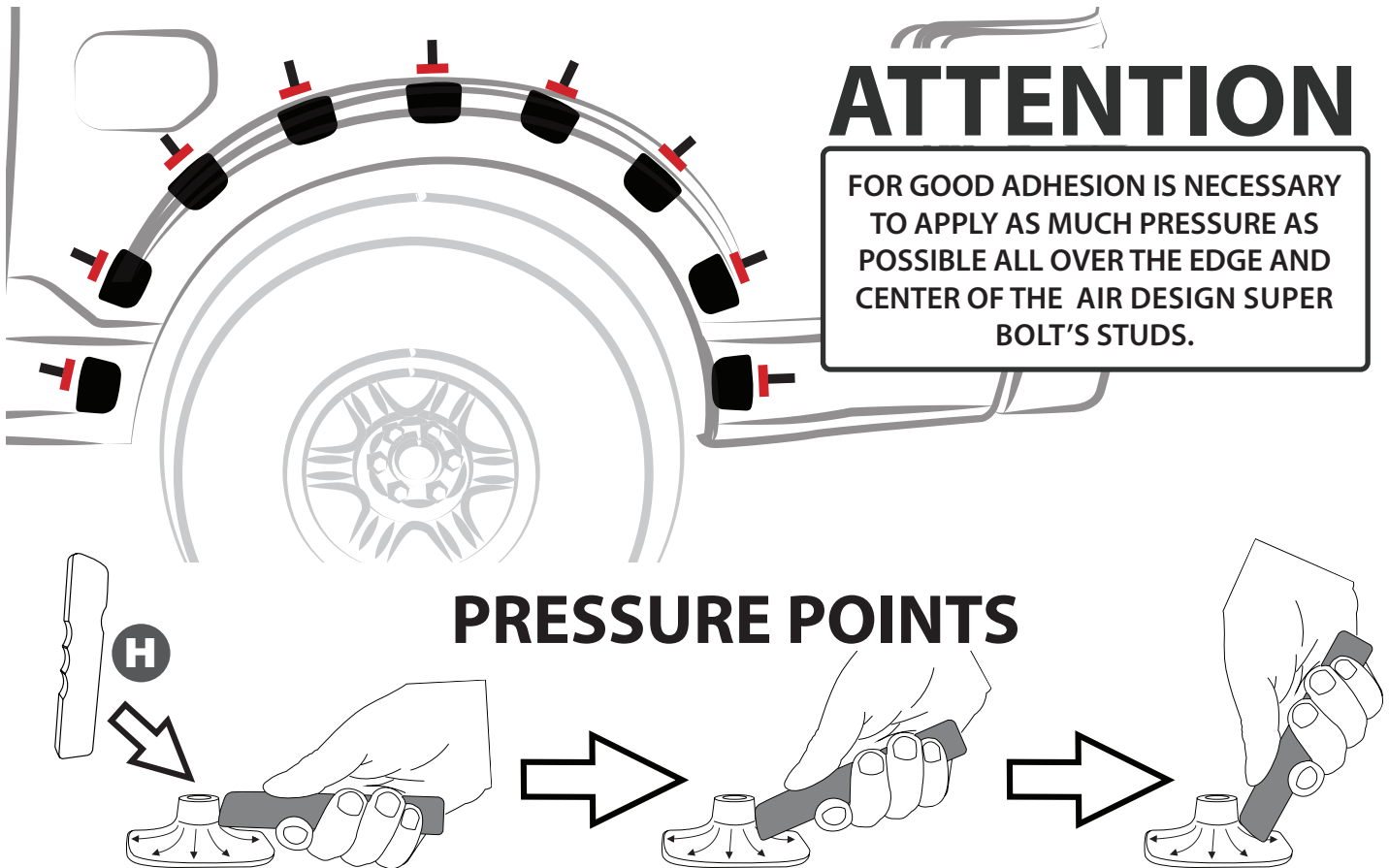

! IMPORTANT

A full surface contact between tape and substrate is decisive for good adhesion performance.

Contact is achieved by applying pressure. In practice a pressure between 40 and 50 N/

cm² is usually needed and an application temperature between 25 and 45 °C or 77 and 113 °F is also necessary.

During application, add-on parts and tapes must have the similar temperature.

13 PLACE THE FENDER FLARE

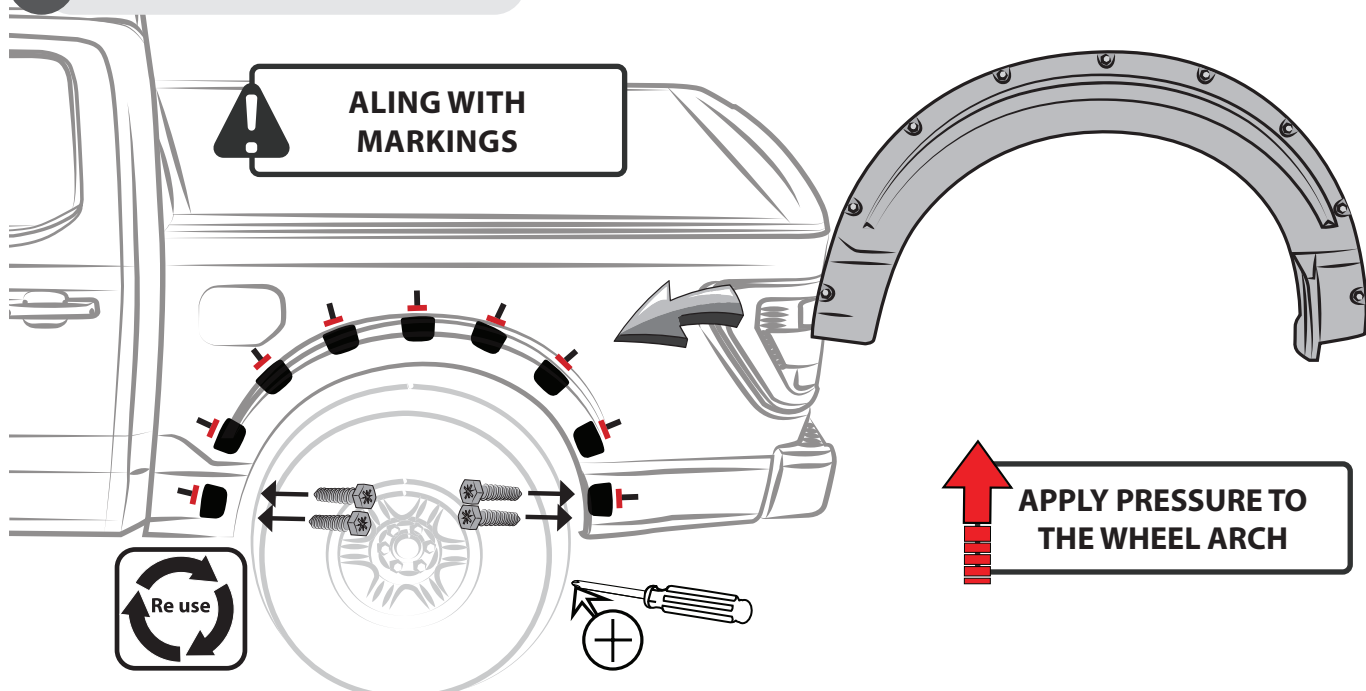

AIR DESIGN SUPER BOLT FENDER FLARE SET

SET NUMBER: FO31A16

14 PLACE AIR DESIGN SUPER BOLTS

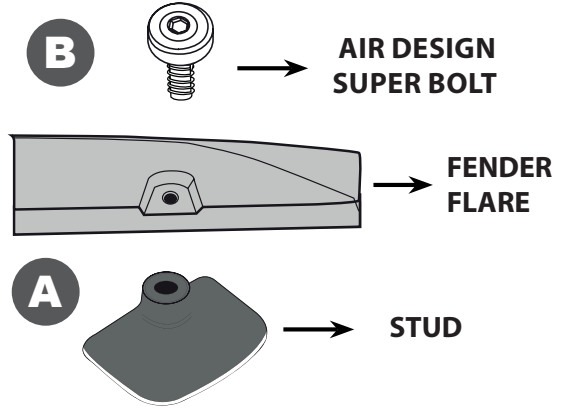

! APPLY THREAD LOCKER TO EACH AIR DESIGN SUPER BOLT

! HAND TIGHT

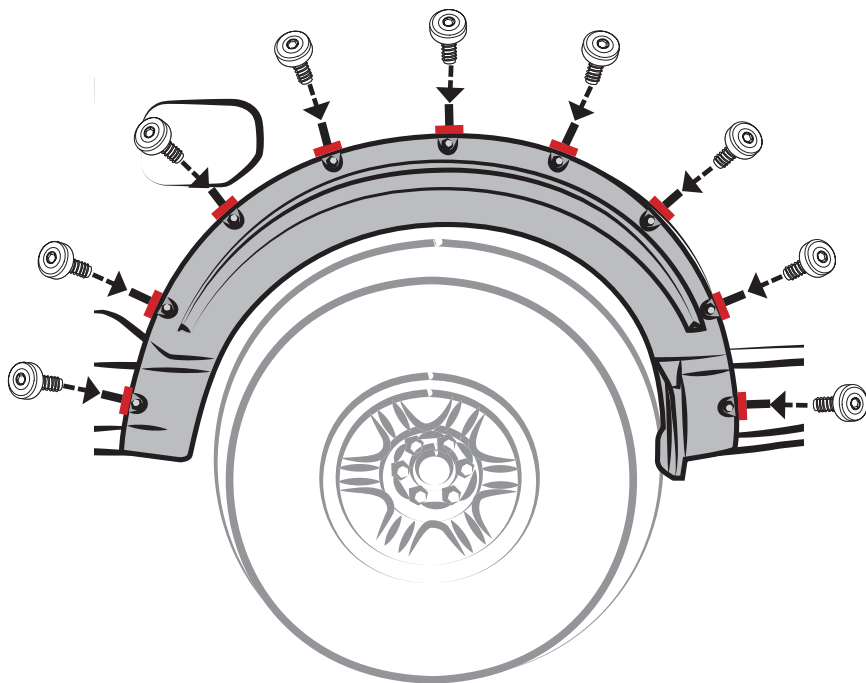

! DON'T FORCE IT ONCE IT HAS STOPPED

15 SCREW FENDER FLARE

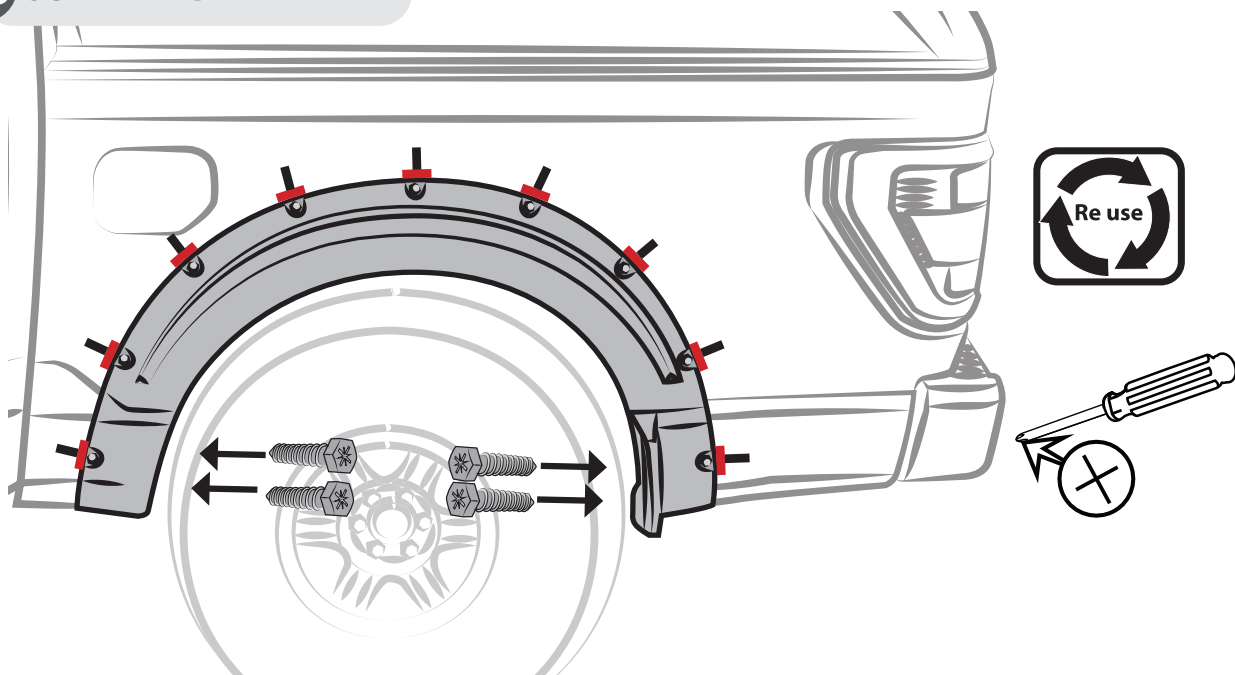

16 PLACE THE SUPPORTS U05 & U04 U-CLIP

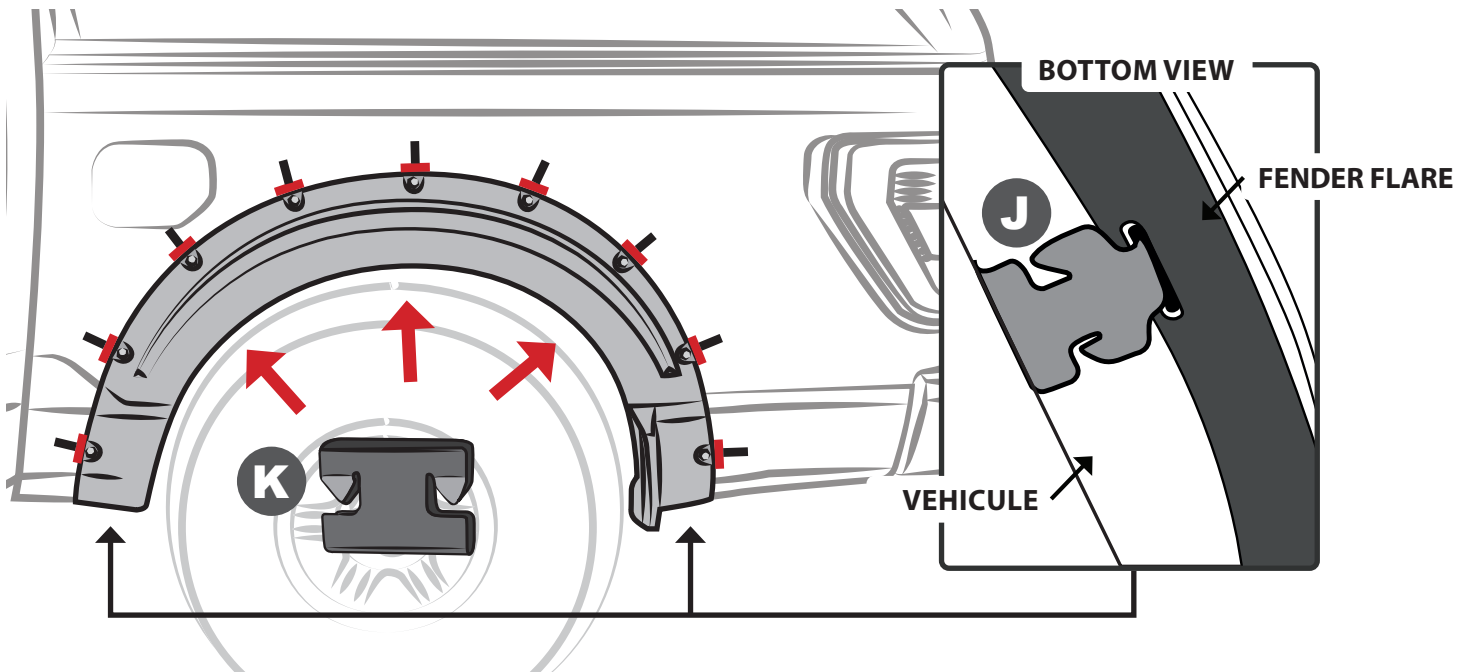

17 CLEAN OFF GREASE PENCIL MARK

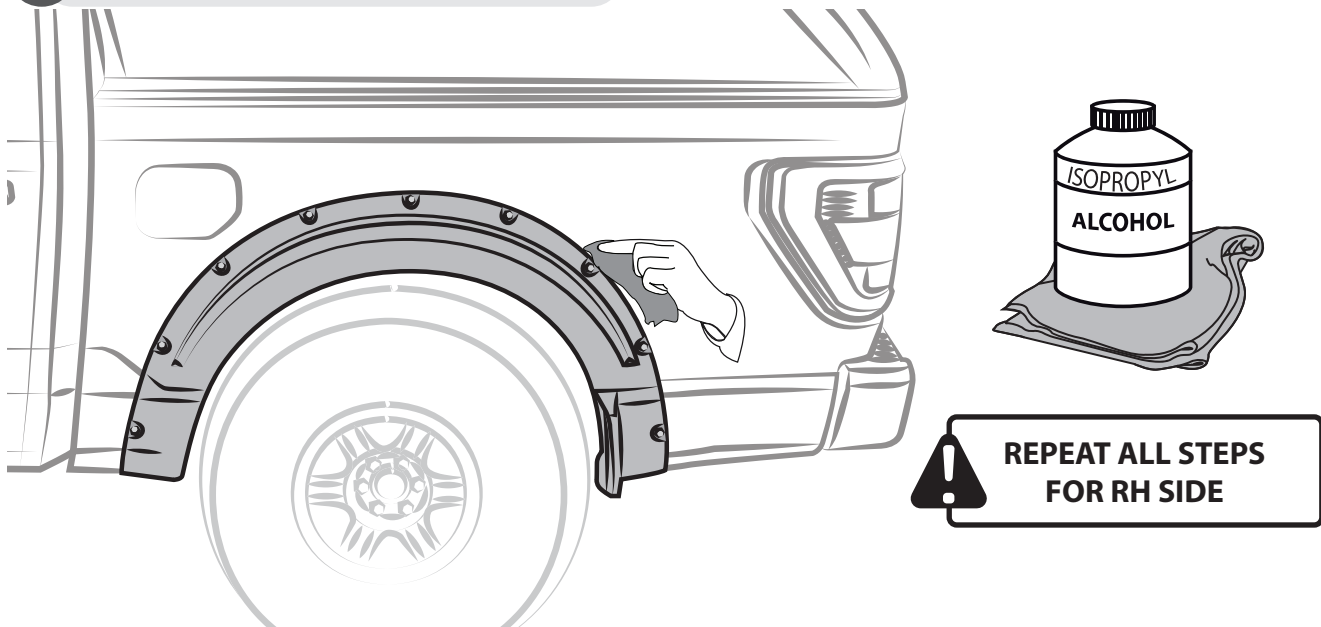

INSTALLED PARTS

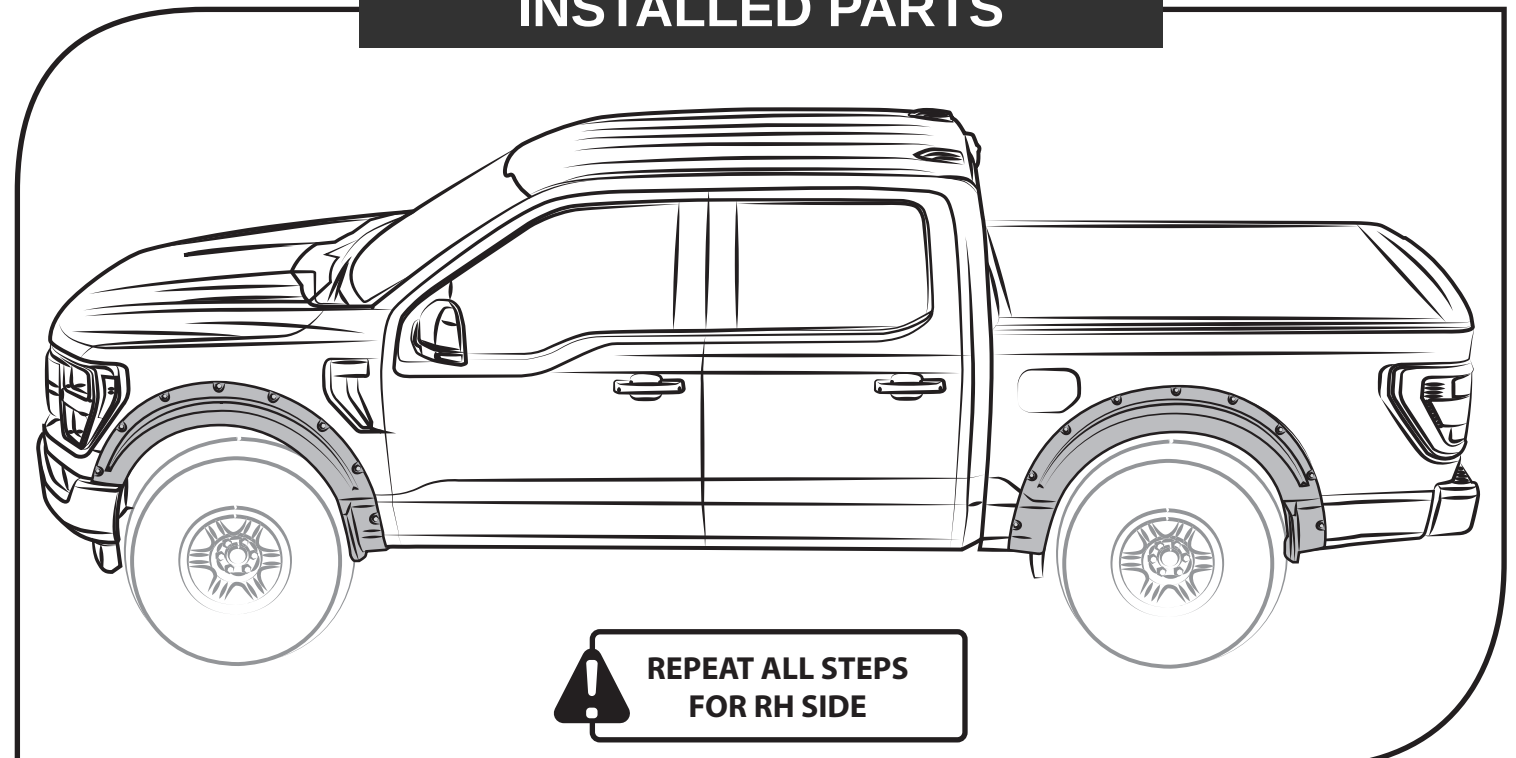

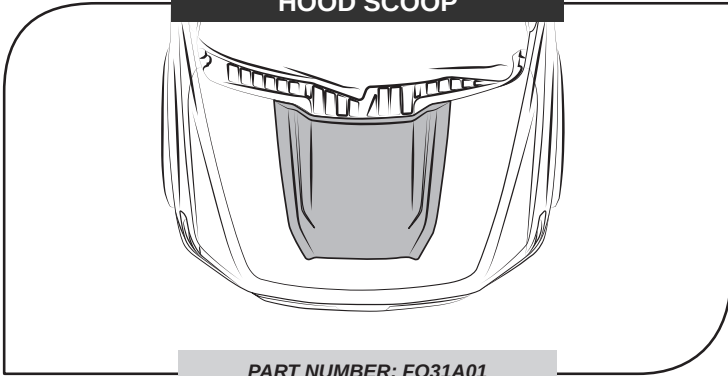
BODY KIT OFF ROAD**HOOD SCOOP**

PART NUMBER: FO31A01

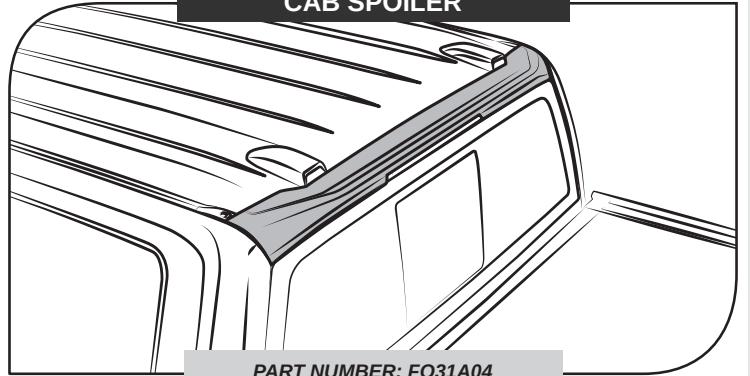
CAB SPOILER

PART NUMBER: FO31A04

TAILGATE SPOILER

PART NUMBER: FO31A05

TAILGATE APPLIQUE

PART NUMBER: FO31A06

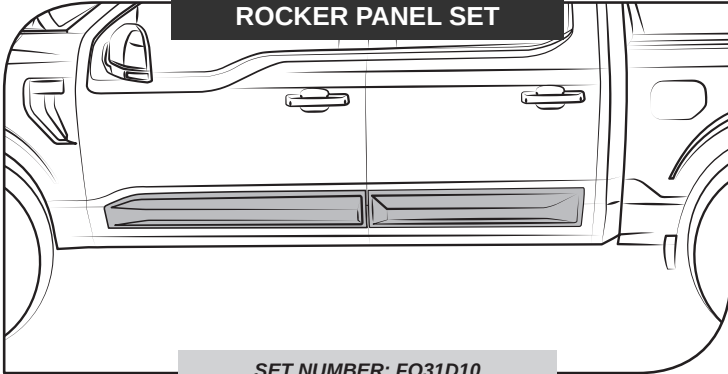
**CREW CAB DOOR
ROCKER PANEL SET**

SET NUMBER: FO31D10

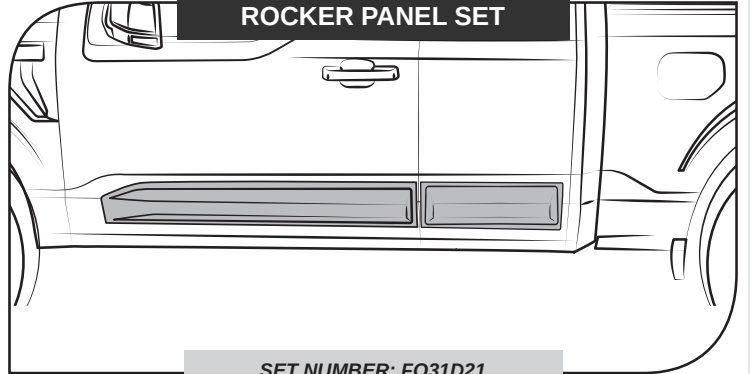
**SUPER CAB DOOR
ROCKER PANEL SET**

SET NUMBER: FO31D21

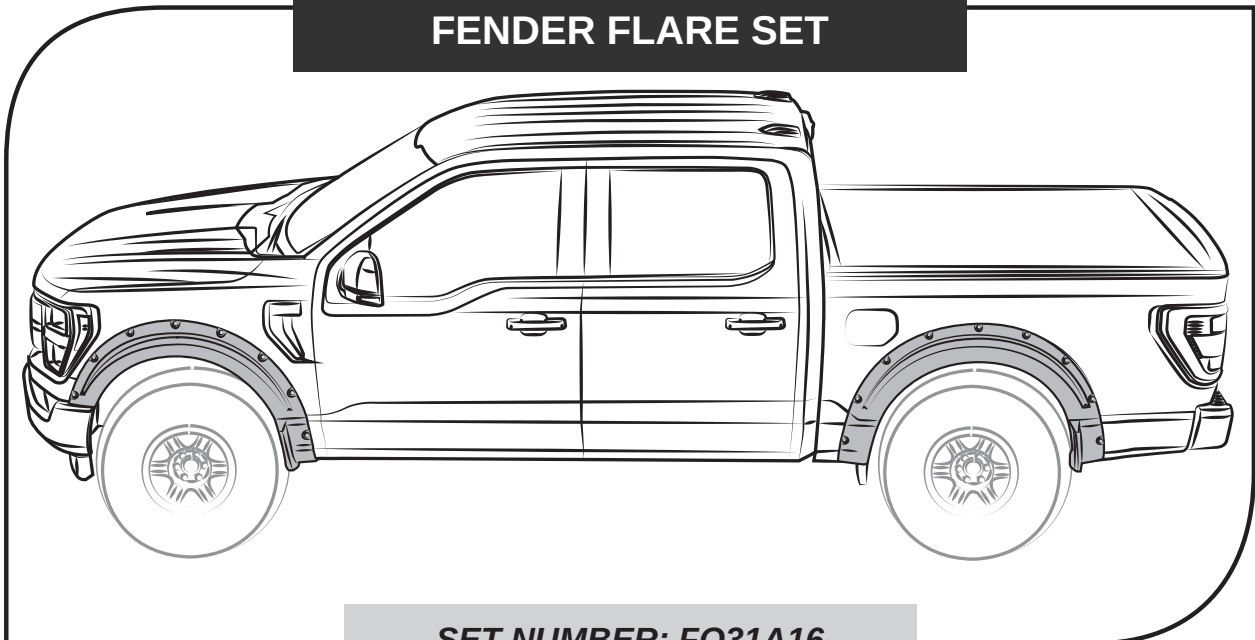
**AIR DESIGN SUPER BOLTS
FENDER FLARE SET**

SET NUMBER: FO31A16