

**DAX**

# Bathroom Faucet.

## **DAX-8108B**

Dax single handle bathroom vessel faucet

- Matt black finish
- Brush nickel finish
- Chrome finish

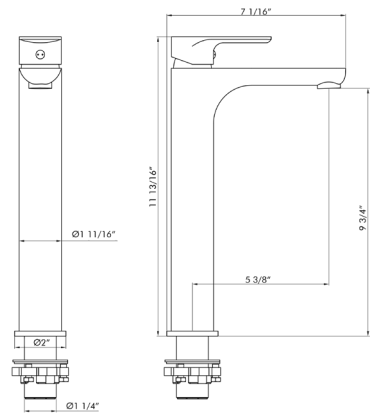

**DAX-8108B-BL**



**DAX-8108B-BN**



**DAX-8108B-CR**

## Product Care.

Bathroom and kitchen products are an essential part of any home, but they can be easily damaged if not properly cared for. Here are some tips on how to keep your faucets looking their best:

- Clean regularly with a mild soap and water solution. Do not use harsh chemicals or abrasive cleaners, as these can damage the finish.
- Wipe up spills immediately. This will prevent them from setting in and causing stains.
- Dry the faucet thoroughly after cleaning. This will help to prevent moisture damage.
- Avoid using hot objects on the faucet. This could cause the finish to crack or warp.
- Do not expose the faucet to direct sunlight or extreme temperatures. This could cause the finish to fade or crack.

### Additional Tips

For tough stains, you can use a mild abrasive cleaner. Be sure to test the cleaner in an inconspicuous area first to make sure it does not damage the finish. You can also use vinegar and water solution to clean your faucet. This is a natural cleaner that is safe for most faucet finishes. To protect your faucet from scratches, you can apply a coat of automotive wax

once a year. This will create a barrier that will help to prevent scratches. Finishes A variety of finishes, each with its own care requirements. Here are some tips for caring for different finishes: Chrome: Chrome is a durable finish that can be easily cleaned with a mild soap and water solution. Be sure to dry the item thoroughly after cleaning to prevent water spots. Nickel: Nickel is another durable finish that is easy to care for. You can use a mild soap and water solution or a commercial nickel polish to clean your nickel product. Be sure to dry thoroughly after cleaning.

Stainless steel: Stainless steel is a very durable finish that can be cleaned with a mild soap and water solution or a commercial stainless-steel cleaner. Be sure to dry the faucet thoroughly after cleaning. Brass: Brass is a beautiful finish that requires a little more care than other finishes. You can use a mild soap and water solution to clean your brass products but be sure to dry them thoroughly after cleaning. You can also use commercial brass polish to keep looking its best. Oil-rubbed bronze: Oil-rubbed bronze is a unique finish that requires special care. You can use a mild soap and water solution to clean your oil-rubbed bronze product but be sure to dry it thoroughly after cleaning. You can also use a commercial oil-rubbed bronze cleaner to keep your faucet looking its best. By following these simple care instructions, you can help to keep your bathroom and kitchen products looking their best for years to come.

## Warranty.

Limited Warranty on DAX® Faucets and Showers Parts and Finish All parts (other than electronic parts and batteries) and finishes of this DAX® faucet are warranted to the original consumer purchaser to be free from defects in material and workmanship, for five (10) years from the date of purchase. On the shower panels, the time of warranty is two (2) years. What We Will Do DAX will repair or replace, free of charge, during the applicable warranty period (as described above), any part or finish that proves defective in material and/or workmanship under normal installation, use and service. If repair or replacement is not practical, DAX may elect to refund the purchase price in exchange for the return of the product. These are your exclusive remedies.

What Is Not Covered Any labor charges incurred by the purchaser to repair, replace, install or remove this product are not covered by this warranty. DAX shall not be liable for any damage to the faucet resulting from reasonable wear and tear, misuse, abuse, neglect or improper or incorrectly performed installation, maintenance, or repair, including failure to follow the applicable care and cleaning instructions. DAX recommends using a professional plumber for all installation and repair. We also recommend that you use only genuine DAX® replacement parts. What You Must Do to Obtain Warranty Service or Replacement Parts A warranty claim may be made. Replacement parts may be obtained by emailing at [cs@daxib.com](mailto:cs@daxib.com) or by writing to: DAX International Brokers INC 8600 NW South River Drive Miami, Florida 33166 Proof of purchase (original sales receipt) from the original purchaser

er must be made available to DAX for all warranty claims. This warranty applies only to DAX® faucets manufactured after January 1, 2012, and installed in the United States of America. Limitation on Duration of Implied Warranties. To the extent permitted by law, any implied warranty, including the implied warranties of merchantability and of fitness for a particular purpose, is limited to the statutory period or the duration of this warranty, whichever is shorter. Some states/provinces do not allow limitations on how long an implied warranty lasts, so the above limitation may not apply to you. Limitation of Special, Incidental or Consequential Damages. DAX shall not be liable for any special, incidental, or consequential damages (including labor charges to repair, replace, install or remove this product); whether arising from breach of any express or implied warranty, breach of contract, tort, or otherwise. DAX faucet company shall not be liable for any damage to the faucet resulting from reasonable wear and tear, misuse, abuse, neglect, or improper or incorrectly performed installation, maintenance, or repair, including failure to follow the applicable installation, care, and cleaning instructions. Some states/provinces do not allow the exclusion or limitation of special, incidental, or consequential damages, so the above limitations and exclusions may not apply to you. Additional Rights This warranty gives you specific legal rights, and you may also have other rights which vary from state/province to state/province. This is DAX's exclusive written warranty, and the warranty is not transferable. If you have any questions or concerns regarding our warranty, please contact us at [info@daxib.com](mailto:info@daxib.com)

**daxib.com**

Phone  
+1 (888) 685 8236

Email  
[info@daxib.com](mailto:info@daxib.com)



Instagram  
[@dax.home](https://www.instagram.com/dax.home)



Facebook  
[DAXIB](https://www.facebook.com/DAXIB)



Pinterest  
[daxintl](https://www.pinterest.com/daxintl)



houzz  
[dax-international](https://www.houzz.com/dax-international)