



**DAX**

**DAX-AT100SP**



TOP MOUNT KITCHEN SINKS **SERIES**



[www.daxib.com](http://www.daxib.com)

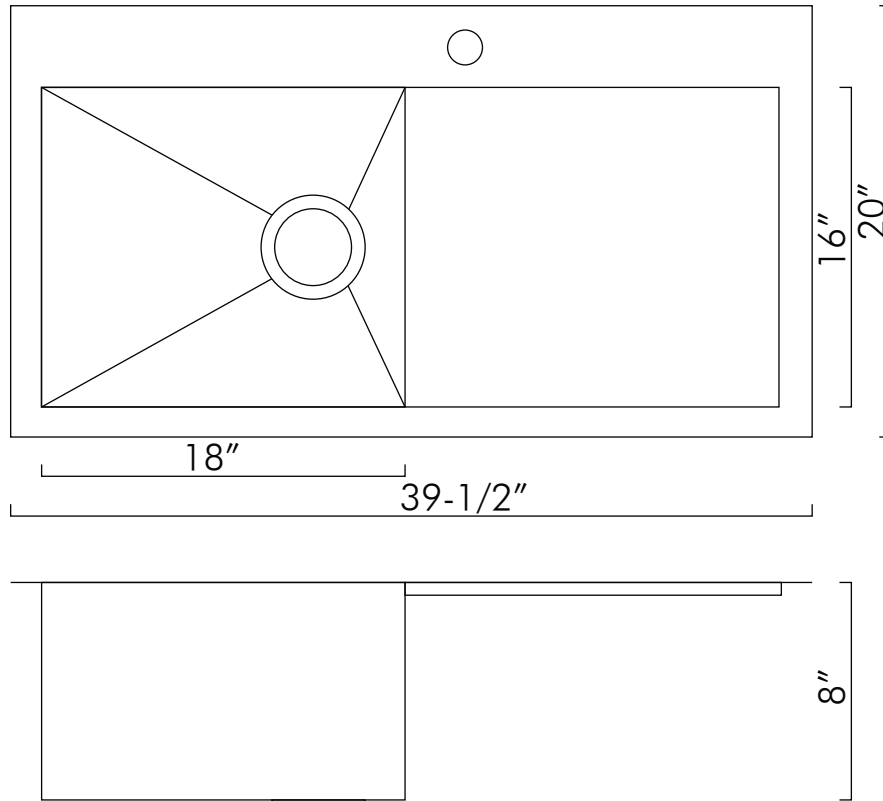

## FEATURES

- Handmade sink
- 0mm radius corner
- Overmount
- 304 Stainless Steel
- 18 gauge
- Brushed Stainless Steel
- Size W 39-1/2" x H 20" x D 8"
- Standard 3-1/2" drain opening
- Undercoated and sound pads
- Mounting clips and cutting template

## ACCESSORIES

- Bottom grid included
- Stainless steel standard strainer included
- Overflow drain (parts included)

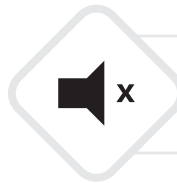

**TOP QUALITY  
SOUNDPROOFING**

Thick rubber dampening pads absorb vibration and noise, ensuring quieter use.



**PROTECTIVE  
UNDERCOATING**

Commercial-grade non-toxic undercoating provides extra soundproofing and prevents condensation buildup in the base cabinet

**HANDMADE**  
BY ARTISANS

UNIQUELY  
HAND CRAFTED  
BY **ARTISANS**

**x** SOUND  
DAMPENING

**EXTRA-THICK**  
3 mm  
RUBBER PADS

**18G**  
THICK STEEL

DURABLE  
**1.2 mm STEEL**  
CONSTRUCTION

PREMIUM GRADE  
**304**

**18% CHROMIUM**  
**10% NICKEL**  
COMPOSITION

HIGH QUALITY  
**DAX**  
WARRANTY  
PRODUCTS

CONSULTING  
AT **DAXIB.COM**



**KITCHEN SINK DAX-AT100SP**

MODEL	DAX-AT100SP
INNER BASIN WIDTH (in)	18"
INNER BASIN HEIGHT (in)	16"
HEIGHT	20"
DEPTH	8"
WIDTH	39-1/2"
BASIN RACK INCLUDED	No
BASIN SPLIT	No
BASKET STRAINER INCLUDED	Yes
COLANDER INCLUDED	No
DRAIN CONNECTION	Yes
DRAIN PLACEMENT	Yes
FARMHOUSE	No
FAUCET HOLES	One
GAUGE	18
INSTALLATION TYPE	Overmount
MATERIAL	SUS304
MOUNTING HARDWARE INCLUDED	Yes
NUMBER OF BASINS	One
PRODUCT WEIGHT	30.027 lb
SINK SHAPE	Rectangle
SOUND DAMPENING	Yes
STAINLESS STEEL GRADE	SUS304
UPC APPROVED	No
SINK FINISH TYPE	Brushed Stainless Steel
OVERFLOW	Yes

For parts or sale requirements please contact our customer service department:

 [CS@daxib.com](mailto:CS@daxib.com)

 1 888 685 8236