

VEGETABLE CUTTING MACHINE

USE – MAINTENANCE

GSV-112



1. INFORMATION ON SAFETIES

1.1. GENERAL PRECAUTIONS

- THE VEGETABLES CUTTING MACHINE MUST BE MANAGED BY SKILLED PERSONNEL, FAMILIAR WITH THE INSTRUCTIONS FOR USE AND SAFETY CONTAINED IN THIS MANUAL.
- IN THE CASE OF ROTATION OF THE PERSONNEL, VOCATIONAL TRAINING IS NECESSARY.
- EVEN IF THE MACHINE COMES WITH SEVERAL SAFETY SYSTEMS, AVOID SETTING THE HANDS NEAR THE CUTTING DISCS AND MOVING PARTS.
- BEFORE ANY CLEANING AND MAINTENANCE OPERATIONS, CHECK TO MAKE SURE THE MACHINE IS DISCONNECTED FROM THE MAINS.
- PERIODICALLY CHECK CABLES AND ELECTRIC ELEMENTS CONDITIONS.
- NEVER USE THE CUTTING MACHINE WITH FROZEN FOOD.
- NEVER REPLACE PARTS OF THE MACHINE BY YOURSELF, BUT APPLY TO THE ASSISTANCE SERVICE.

1.2. MECHANICAL SAFETIES

THE VEGETABLES CUTTING MACHINE WE PRODUCE AND WHICH IS DESCRIBED IN THIS MANUAL MEET, AS FAR AS SAFETIES ARE CONCERNED, THE PRESCRIPTIONS ON THE RISKS OF MECHANICAL TYPE ISSUED BY GB4706.38-2003.

1.3 ELECTRICAL SAFETIES

THE SAFETIES AGAINST ELECTRICAL RISKS COMPLY WITH THE REGULATIONS CENELEC GB4706.38-2003. A SECURITY MICROSWITCH IS MOUNTED ON THE MACHINE TO STOP THE MACHINE OPERATION WHEN THE COVER IS OPENED TO GAIN ACCESS TO THE CUTTING DISCS, AND ANOTHER MICROSWITCH ON THE INLET OF THE MATERIAL.

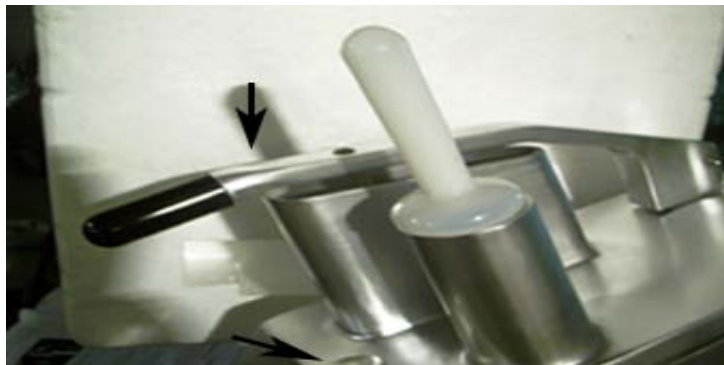

SETTING N.2 MICROSWITCHES

A RELAY REQUIRING REQUIRES THE VOLUNTARY RESTART (ACTIVATION) OF THE MACHINE WHEN THE CURRENT IS LACKING HAS BEEN SET ON THE LOW VOLTAGE CONTROL CIRCUIT. FOR THE PERFECT INSULATION OF ALL THE ELECTRIC ELEMENTS AND THE REMARKABLE RESISTANCE OF THE ALUMINIUM TREATMENT, COUPLED WITH THE MATERIAL USED, OUR MACHINES CAN BE INSTALLED TO WORK INSIDE MOIST PREMISES.

2. TECHNICAL FEATURES

TECHNICAL FEATURES OF VEGETABLE CUTTING MACHINE FOR MODEL HL300.

- THEIR USE, CLEANING AND MAINTENANCE IS QUITE SAFE.

THANKS TO THEIR DESIGN AND TO THE REALIZATION OF ALL PARTS IN ALUMINIUM AND MAGNESIUM ALLOY WITHOUT EDGES FOR EASY CLEANING OPERATIONS.

2.1. TABLE OF WEIGHT AND MEASURES

<u>MODEL</u>	<u>DIMENSIONS</u> <u>CM.</u>	<u>WEIGHT</u> <u>KG.</u>	<u>POWER</u> <u>WATT</u>	<u>ELECTRICAL</u> <u>CONNECTION</u>	<u>REVS</u> <u>DISC</u>
---------------------	---	---	---	--	--

HLC-300	57X23X51	22.50	550	220/1/50	270
---------	----------	-------	-----	----------	-----

2.2. SUPPLY CONDITIONS AND DISPOSAL OF PACKINGS

THE CUTTING MACHINE IS PACKED IN A STURDY CARDBOARD BOX WITH INTERNAL SHAPED EDGES WHICH GUARANTEE THE PERFECT INTEGRITY OF THE MACHINE DURING TRANSPORT.

THE EQUIPMENT INCLUDE:

- INSTRUCTIONS FOR USE AND MAINTENANCE
- HIGH EJECTING DISC AND LOW EJECTING DISC

ALL THE PACKING COMPONENTS (CARTON, FOAM, STRAPS, AND SO ON) CAN EASILY BE DISPOSED OF AS HOUSEHOLD RUBBISH

3. INSTALLATION

3.1. SETTING THE MACHINE

THE MACHINE CONNECTION AND THE SETTING AT WORK MUST BE MADE BY SKILLED PERSONNEL.

WARNING: BOTH THE SYSTEM AND LOCATION WHERE THE EQUIPMENT HAS TO BE SET MUST COMPLY WITH THE REGULATIONS FOR THE ACCIDENT PREVENTION AND ELECTRICAL REGULATIONS IN FORCE.

THE MANUFACTURER DECLINES ANY AND ALL RESPONSIBILITY FOR DIRECT OR INDIRECT DAMAGES WHICH MAY ENSUE FOR NON-COMPLIANCE WITH THE ABOVE MENTIONED REGULATIONS.

SET THE EQUIPMENT ON A WIDE, LEVELLED, DRY AND FIXED FACE, FAR FROM HEAT SOURCES AND WATER SPRAYS.

3.2. ELECTRIC CONNECTIONS

THE EQUIPMENT IS SUPPLIED WITH AN ELECTRIC CABLE TO BE CONNECTED TO A MAGNETO-THERMIC MAIN SWITCH WHICH STOPS THE MACHINE WHEN THE OPERATOR COMES IN FORTUITOUS CONTACT WITH THE ROTATING ELEMENTS.

IT IS IMPERATIVE THAT THE EQUIPMENT IS WELL GROUNDED ACCORDING TO THE REGULATIONS IN FORCE.

THE MANUFACTURER DECLINES ANY AND ALL RESPONSIBILITY FOR DIRECT AND INDIRECT DAMAGES WHICH MAY ENSUE FOR NON-COMPLIANCE WITH THE REGULATIONS IN FORCE.

THE CUTTING MACHINE IS MANUFACTURED INTO SINGLE-PHASE V.220/1/50 HZ.

WHENEVER THE VOLTAGE DIFFERS FROM THE ABOVE MENTIONED, PLEASE APPLY TO THE MANUFACTURER, OR THE AUTHORIZED DISTRIBUTOR. (SEE FIGURE)

THREE-PHASE CONNECTION

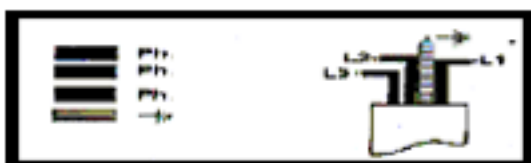

SINGLE-PHASE CONNECTION

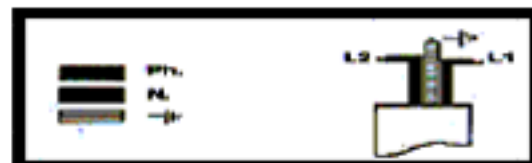

WARNING

OPEN THE COVER, ROTATE THE SIDE HANDLE AND REMOVE THE CUTTING DISC (IF ANY) WITH IDLE MACHINE, (OR WITH THE WHITE PLASTIC EJECTOR ONLY), THROUGH THE UPPER (ROUND) OPENING, AND BY PRESSING ONCE THE START GREEN BUTTON FOLLOWED BY STOP RED BUTTON, CHECK TO MAKE SURE THE CENTRAL PIN DIRECTION OF ROTATING IS ANTICLOCKWISE.

SHOULD NOT THE DIRECTION OF ROTATION BE CORRECT, REVERSE TWO OF THE THREE SUPPLY WIRES (INSIDE THE PLUG OR SOCKET).

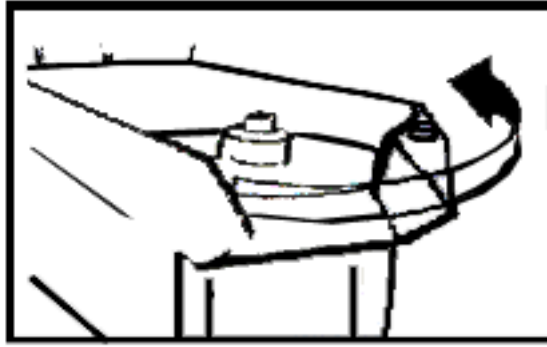

CHECKING THE DIRECTION OF ROTATION

3.3. SAFETY MEASURES AND TRAINING THE FINAL USER

THE SKILLED PERSONNEL IN CHARGE OF THE INSTALLATION AND ELECTRIC CONNECTIONS OF THE EQUIPMENT IS RESPONSIBLE OF THE TRAINING OF THE FINAL USER, WHICH MUST ALSO BE INFORMED ON THE SAFETY MEASURES TO COMPLY WITH. THIS INSTRUCTION MANUAL COMES WITH EACH EQUIPMENT.

4. USE OF THE EQUIPMENT

4.1. CONTROLS

THE CONTROLS AND PILOT LIGHT ARE SENT ON THE RIGHT SIDE OF THE BASE WHEN THE MACHINE IS LOCATED IN FRONT OF THE OPERATOR.

1. GREEN BUTTON FOR STARTING THE MACHINE
2. RED BUTTON FOR STOPPING THE MACHINE



4.2. SETTING THE DISCS ON THE MACHINE

ROTATE THE KNOB AS SHOWN IN FIGURE N.1 AND OPEN THE COVER. SET FIRST THE PLASTIC EJECTING DISC (2), THEN THE DISC SELECTED FOR THE CUTTING.

CLOSE THE COVER AND REVERSE THE ROTATION OF THE HANDLE. WORK ON THE START BUTTON TO AUTOMATICALLY HOOK THE DISCS IN THE CORRECT POSITION.



COVER OPENING (1)



DISC POSITION (2)

ATTENTION TO DISC BLADES!!

4.3. SETTING AND CUTTING THE FOOD

LIFT THE HANDLE AND SET THE FOOD INSIDE THE OPENING AS SHOWN IN FIGURE N.3, THEN CLOSE THE HANDLE.

PRESS THE GREEN START BUTTON WITH YOUR RIGHT HAND, AND WITH YOUR LEFT HAND, LIGHTLY MOVE THE HANDLE DOWNWARDS UNTIL FOOD IS FULLY USED UP.



(3)

LIFT THE HANDLE TO INTRODUCE OTHER FOOD.

THE MACHINE STARTS AUTOMATICALLY WHEN THE HANDLE IS CLOSED. REPEAT THESE OPERATIONS UNTIL THE FOOD IS FULLY USED UP.

IT IS POSSIBLE TO USE THE TWO OPENINGS WITH A SINGLE DISC. WHEN TWO DISCS ARE USED FOR CUTTING STICKS AND MATCH-LIKE FOOD, THE INLET OPENING SET OVER THE GRID MUST BE USED THE SMALLER ROUND OPENING IS USED TO SLIT VEGETABLES AS CARROTS, VEGETABLE MARROWS, AND SO ON.

WARNING: NEVER USE THE HAND, BUT PRESS THE VEGETABLE WITH THE PESTLE SUPPLIED.

4.4. RELEASE AND REPLACEMENT OF THE DISCS

TURN THE KNURLED HANDLE AND LIFT THE COVER. (FIG.1)

TURN THE DISC ANTICLOCKWISE AND COVER THE CUTTING EDGE WITH APPROPRIATE MATERIAL AS (RUBBER, FABRIC, ETC), THEN LIFT IT BY SETTING YOUR HAND UNDER THE DISC.

SIMPLY LIFT THE DISCS TO REMOVE THE GRID DISC FOR DICE CUTTING, OR THE DISC FOR STICK CUTTING WITH THE PLASTIC DISC. (FIG4-5)



(4)



(5)

5. CLEANING AND MAINTENANCE OPERATIONS

5.1. GENERALITIES AND PRODUCTS FOR CLEANING

BEFORE CARRYING OUT ANY CLEANING OR MAINTENANCE OPERATIONS, CHECK TO MAKE SURE THAT THE MAINS SWITCH BE OFF AND THE SUPPLY PLUG DISCONNECTED FROM THE MAINS.

ACCURATELY CLEAN THE EQUIPMENT AND THE DISCS EVERY DAY FOR A CORRECT OPERATION AND LIFE OF THE EQUIPMENT.

THE DISCS, THE GRID FOR CUTTING DICES, AND THE PLASTIC EJECTOR, CAN BE REMOVED FOR WASHING UNDER A WARM WATER JET.

CLEAN THE MACHINE, AND ABOVE ALL WHERE THE DISCS REST, WITH A CLOTH OR A SPONGE WET WITH

WARM WATER, ACCURATELY REMOVE ALL WASTES TO PREVENT THE DISCS FROM CHANGING THEIR POSITION.
 OPEN THE COVER AND LOOSEN THE 2 PINS AS SHOWN IN FIG.6. REMOVE THE COVER AND WASH UNDER A WATER JET.

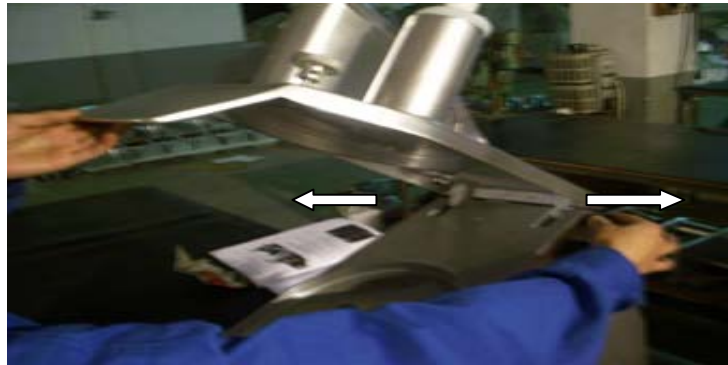

(6)

CLEAN THE SURFACES WITH WATER AND SOAP, ALCOHOL, DETERGENTS WITHOUT ABRASIVES OR SUBSTANCES BASED ON CHLORINE OR SODA (CHLORINE WATER, MURIATIC ACID). NEVER USE ABRASIVES, STEEL WOOL, OR SIMILAR PRODUCTS AS THEY MAY BRING DAMAGES TO THE PAINT, THE COAT, OT THE MACHINE BODY.
 FOR CLEANING, USE NON-TOXIC PRODUCTS AND ONES THAT GUARANTEE THE BEST HYGIENE.

5.2. OPERATIONS IN THE CASE OF FAILURES

WHEN THE WHITE POLIT LIGHT ON THE PANEL IN ON, BUT THE MACHINE DOES NOT START, CHECK TO MAKE SURE THAT THE HANDLE AND THE COVER ARE CLOSED. IN THIS WAY, BOTH THE SAFETY MICROSWITCHES. THE SAFETY MICROSWITCHES PREVENT THE MACHINE START WHENEVER ALL SECURITIES ARE NOT ACTIVATED.

IN THE CASE OF FAILURES, DISCONNECT THE MAIN WALL SWITCH AND EITHER WARN THE MAINTENANCE SERVICE, OR THE SKILLED PERSONNEL. NEITHER START NOR TAMPER WITH THE EQUIPMENT PERSONALLY.

5.3. MACHINE IDLE FOR A LONG TIME

SHOULD THE MACHINE BE IDLE FOR A LONG TIME, DISCONNECT THE MAIN WALL SWITCH AND CLEAN THE MACHINE AND ITS ACCESSORIES ACCURATELY. USE WHITE VASELINE OIL (OR SIMILAR PRODUCTS) TO PROTECT ALL THE MACHINE'S ELEMENTS.
 THESE PRODUCTS, MAINLY MADE UP OF OILY AND DETERGENT SUBSTANCES, AND NOW AVAILABLE IN SPRAY CYLINDERS FOR EASY APPLICANT, BESIDES GIVING A GLOSSY ASPECT TO THE ALUMINIUM MAGNESTISM ALLOY, PREVENT MOISTURE AND DIRT FROM GETTING INSIDE THE MACHINE, HENCE, ITS CORROSION. WE ADVISE COVERING THE MACHINE WITH A NYLON (OR SIMILAR) CLOTH.

ILLUSTRATIONS

110V

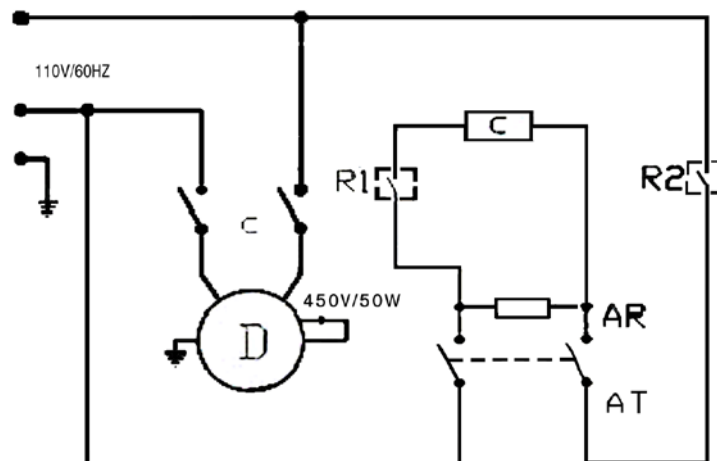

220V

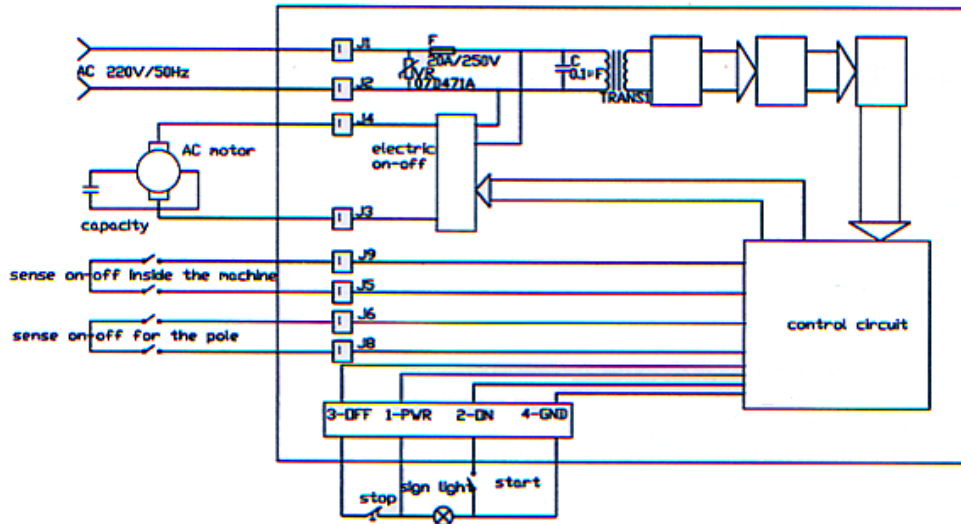

380V

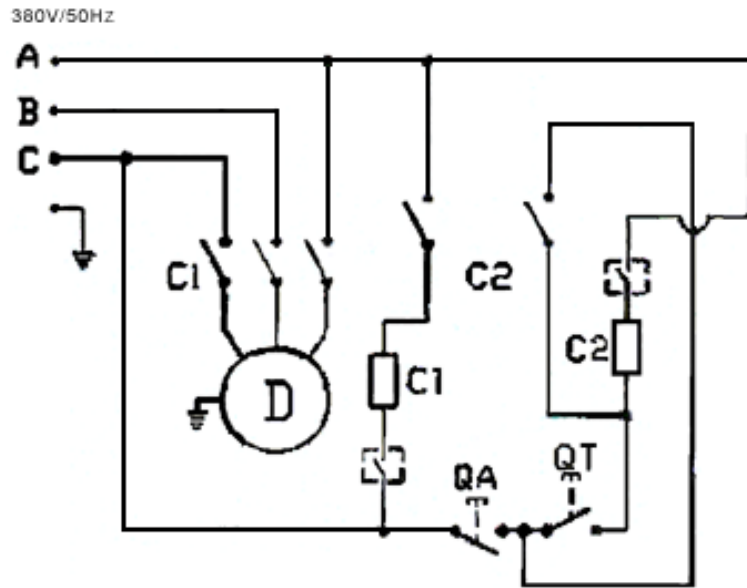

(A)

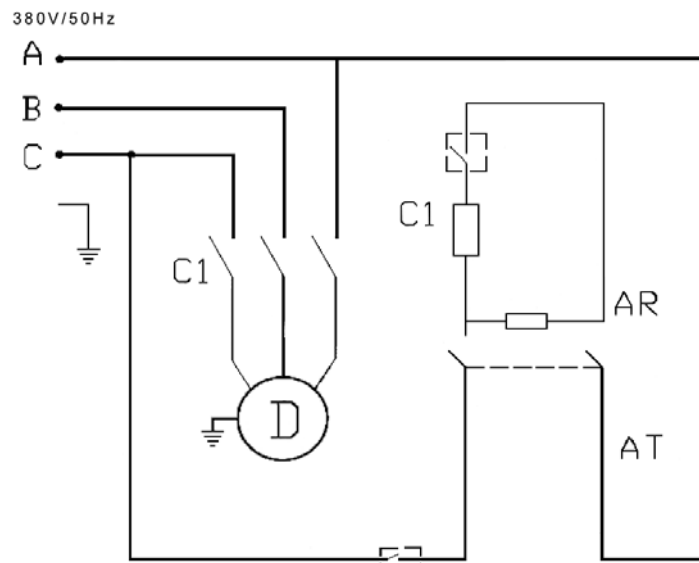

(B)

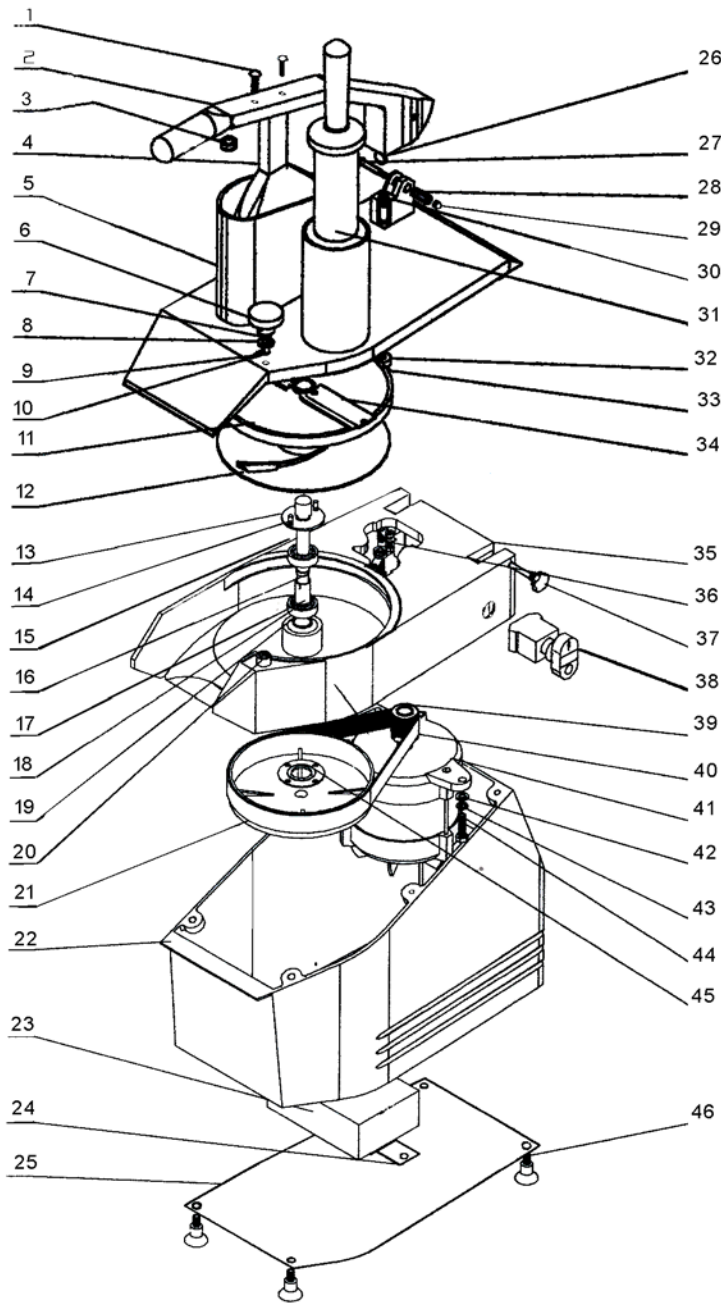

No.	Part Name
300-001	Bolt
300-002	Handlebar
300-003	Nylon gasket
300-004	Pressing piece
300-005	Input body
300-006	Anchor knob
300-007	Spring
300-008	Gasket
300-009	Pin
300-010	Anchor spindle
300-011	Knife disc
300-012	Drain disc
300-013	Anchor board
300-014	Pin
300-015	Oil envelope
300-016	Central spindle
300-017	Isolated sheath
300-018	Gear
300-019	Block circle
300-020	Anchor sheath
300-021	Belt wheel
300-022	Seat of body
300-023	Electric box
300-024	Bottom board of electric box
300-025	Bottom board of body
300-026	Magnet steel
300-027	Umbrella bolt
300-028	Steel sheath
300-029	Nut
300-030	Adjusting bolt
300-031	Plastic pressing stick
300-032	Seat of magnet
300-033	Magnet steel
300-034	Knife
300-035	Body
300-036	Microswitch
300-037	Waved bolt
300-038	Switch
300-039	Strapped wheel
300-040	Belt
300-041	Motor
300-042	Gasket
300-043	Gasket
300-044	Bolt
300-045	Gear cover
300-046	Bolt