



# BEVERAGE-AIR

Project: _____	AIA#
Item: _____	
Location: _____	SIS#
Approved: _____	

**VISTA® BOTTOM MOUNT REACH-IN FREEZER**  
 FB49HC Glass Door Reach-in Freezer  
 Hydrocarbon Series

**MODEL:**  
**FB49HC-1G**

**FB49HC BOTTOM MOUNT MODELS: VISTA® SERIES**



**3 Year Parts/Labor Warranty**  
**Additional 4 Year Compressor Warranty**

**CABINET CONSTRUCTION**

- Stainless steel front and doors, gray painted sides
- Gray painted aluminum interior
- Full electronic control
- LED lighting
- Anti-microbial door handles
- Self-closing doors with 120° Stay-open feature, on spring-loaded hinges
- One-piece grille allow easy removal/installation for preventative maintenance
- Three (3) heavy duty epoxy coated wire shelves per door section
- 6" casters standard with (2) brakes

**OPTIONS & ACCESSORIES**

- Stainless steel universal tray slide (AC)
- Additional epoxy shelves
- Shelf clips
- 3" caster or 6" legs
- Remote option\* (see note on back page)

**REFRIGERATION SYSTEM**

- Uses environmentally friendly, energy efficient R290 refrigerant, and meets all regulatory requirements for CARB, SNAP, DOE & more
- Hot gas condensate evaporator
- Adaptive defrost
- Epoxy coated evaporator coil
- Maintains product temperatures of 0° F and below



  
 Please verify qualifying units by visiting:  
[www.energystar.gov/cfs](http://www.energystar.gov/cfs)

3779 Champion Blvd., Winston-Salem, NC 27105  
 1-888-845-9800 Fax: 1-336-245-6453  
 Beverage-Air.com Sales@bevair.com



# BEVERAGE-AIR

MODEL	FB49HC-1G
<b>EXTERNAL DIMENSIONAL DATA</b>	
Width Overall	52"
Depth Overall with Handle	33 3/4"
Height Overall with 6" Casters	84 1/4"
Number of Doors	2
Depth with Door Open 90°	56 1/8"
Door Opening	22 3/4" x 52 5/8"
<b>INTERNAL DIMENSIONAL DATA</b>	
NET Capacity (cubic ft.)	46.2
Internal Width Overall (in)	49"
Internal Depth Overall (in)	25 7/8"
Internal Height Overall (in)	61 5/8"
Internal Height Useable (in)	53"
Number of Shelves	6
<b>ELECTRICAL DATA</b>	
Full Load Amperes 115/60/1	11.0
<b>REFRIGERATION DATA</b>	
Horsepower	3/4
Capacity (BTU/Hr)*	2312
<b>SHIPPING DATA</b>	
Gross Weight - Crated	564 lbs
Height - Crated	85"
Width - Crated	54"
Depth - Crated	36"

\*NOTE: Remote units are field wired and come with 6" legs. Refrigerant must be specified at time of order.

## Bottom Mount Reach-in Freezer

Model: FB49HC-1G

### Model Views

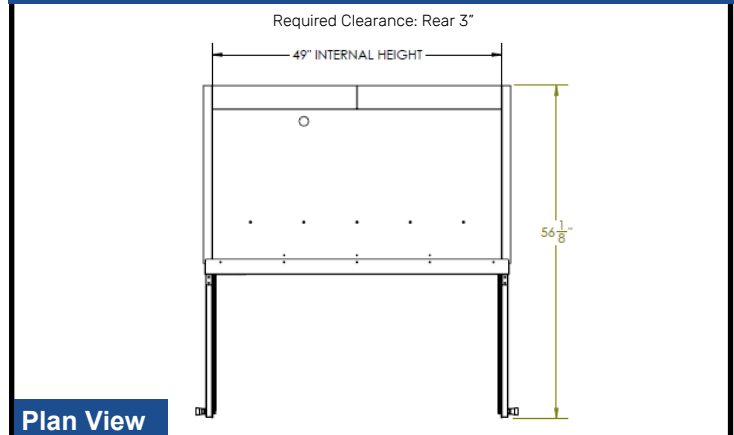

Plan View

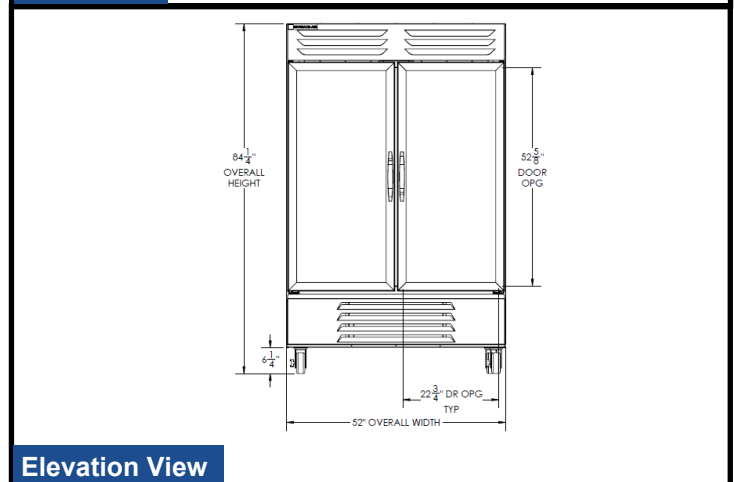

Elevation View

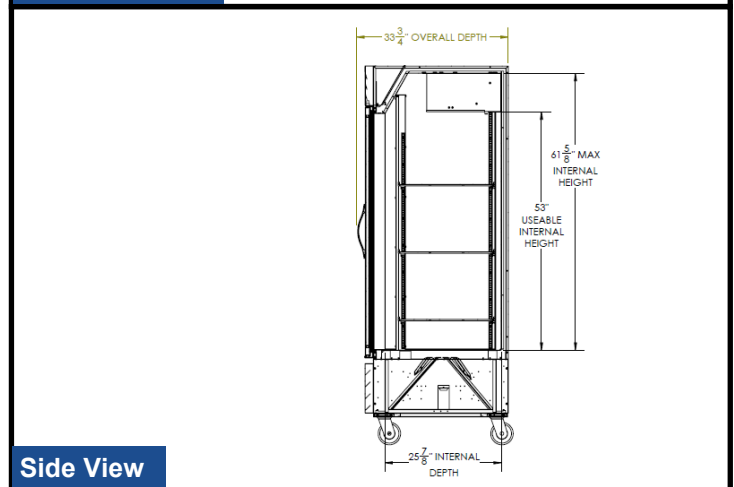

Side View

### ELECTRICAL CONNECTION



115/60/1  
NEMA-5-15P

Units pre-wired at factory and include 8' long cord and plug set.



3779 Champion Blvd., Winston-Salem, NC 27105 1-888-845-9800 Fax: 1-336-245-6453 Beverage-Air.com Sales@bevair.com

an Ali Group Company



The Spirit of Excellence