

AMERICAN RANGE

QUALITY COMMERCIAL COOKING EQUIPMENT

SUHP HOT PLATES

GAS TYPE: NATURAL LP

STANDARD FEATURES

- Easy clean, removable 32,000 BTU burner heads
- Step-Up rear burners are elevated 4" higher than front burners
- Heavy duty removable, 12" x 12" cast iron top grates
- Manual gas control valve for each burner
- Stainless steel pilots for instant ignition on each burner
- Full-width removable crumb tray for easy cleaning
- Die cast, black control knob
- One year limited warranty, parts and labor.

OPTIONS

- Set of 4, 4" counter legs (12" to 48" models)
- Set of 6, 4" counter legs (60" models)
- Saute and wok burner heads
- Stainless steel wok ring adapter



Model SUHP-36-6



American Range ARHP series is designed with safety, durability and convenience in mind, with heavy duty construction and uniquely designed top grates. These products will provide years of trouble-free performance in the most demanding service operation. Uncompromising quality, performance and service at an affordable price.

SUHP HEAVY DUTY OPEN-BURNER HOT PLATES

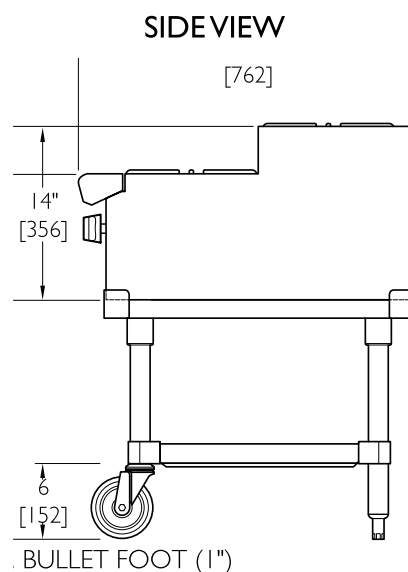
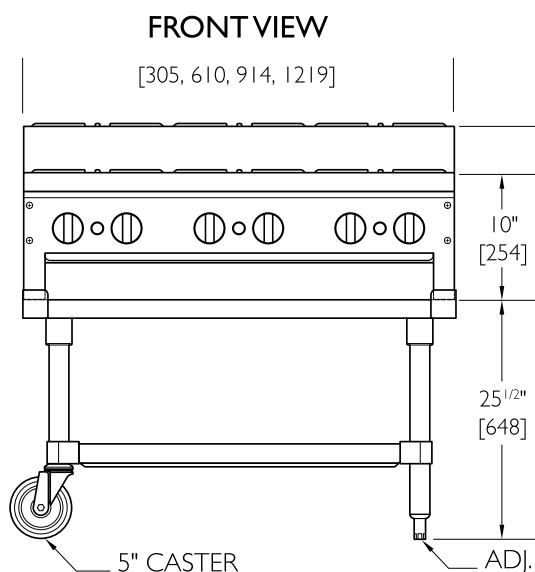

SUHP

Shown with optional Heavy Duty Equipment Stand, Swivel Casters & Adjustable Legs



ARHP-12-2

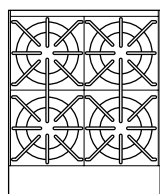

ARHP-24-4

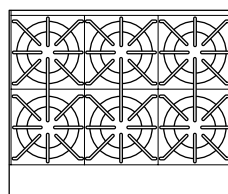

ARHP-36-6

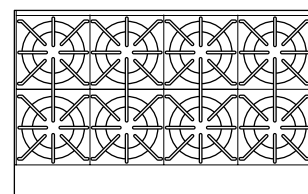

ARHP-48-8

HEAVY DUTY SET-UP HOT PLATES

Model	Width	Depth	Height	Burners	Total BTU	(KW)	Shipping Weight Lbs.	(Kg.)
SUHP-12-2	12"	30"	14"	2	64,000	(18)	185	61
SUHP-24-4	24"	30"	14"	4	128,000	(37)	210	95
SUHP-36-6	36"	30"	14"	6	192,000	(56)	355	161
SUHP-48-8	48"	30"	14"	8	256,000	(75)	380	172

GAS SUPPLY:

3/4" NPT Gas inlet. Manifold pressure is 5.0" W.C. for natural gas or 10.0" W.C. for propane gas. Specify type of gas and altitude if over 2000 feet.

CLEARANCES:

For use only on non-combustible floors. Legs or casters are required, or 2" (51) overhang is required when curb mounted. Clearance from non-combustible walls is 0". When unit is placed next to combustible walls, clearances must exceed 12" (305) on sides, and 4" (102) from rear. Radiant broilers for non-combustible locations only.

American Range is a quality manufacturer of commercial cooking equipment. Because of continuing product improvements these specifications are subject to change without prior notice.