

# METAL CUTTING BAND SAW MACHINE

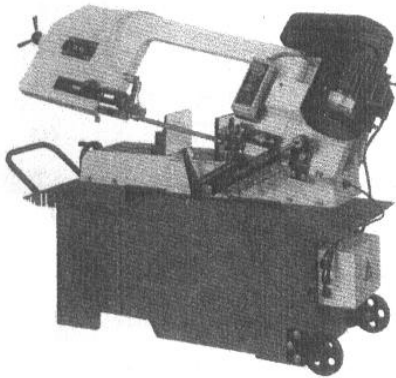

912B

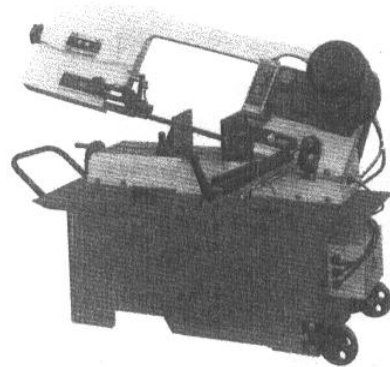

912G

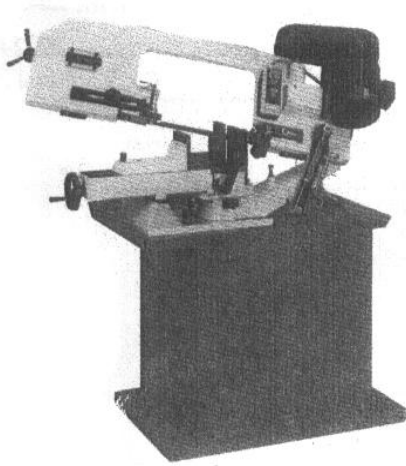

912DR

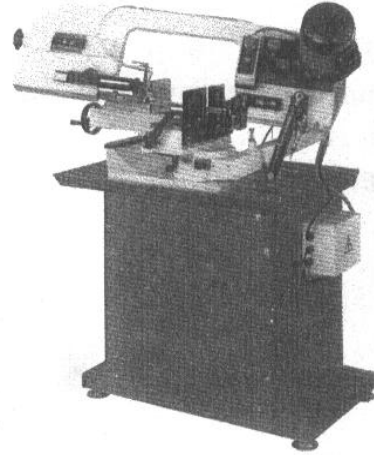

912GDR

## MODEL 912 SERIES INSTRUCTION MANUAL

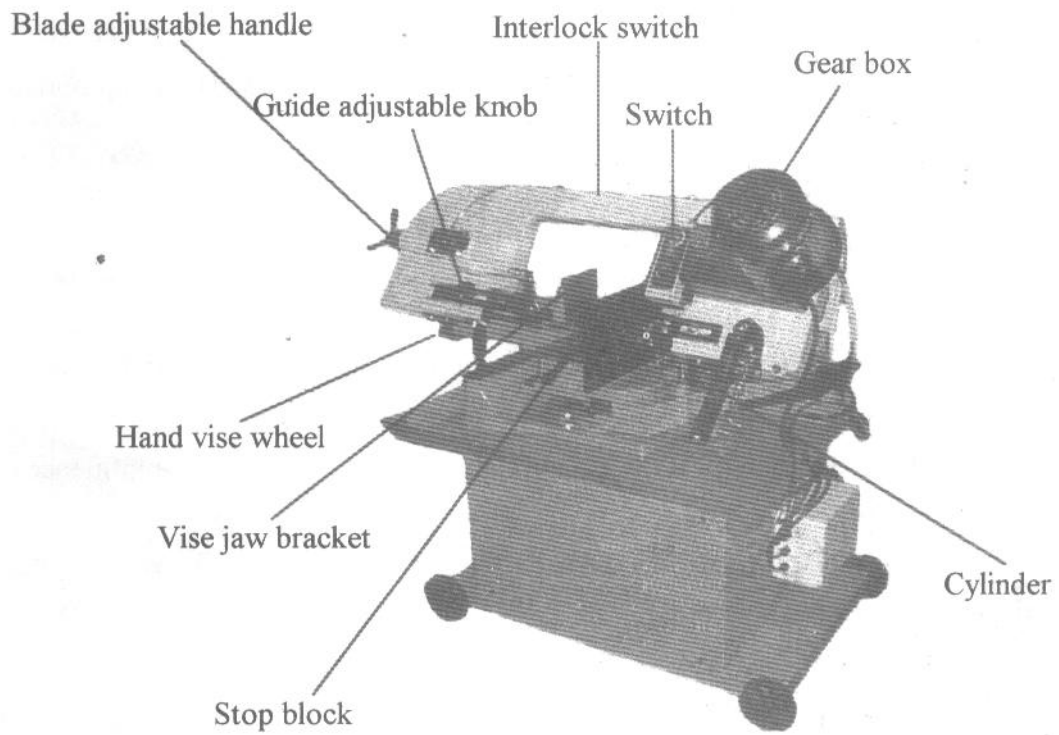
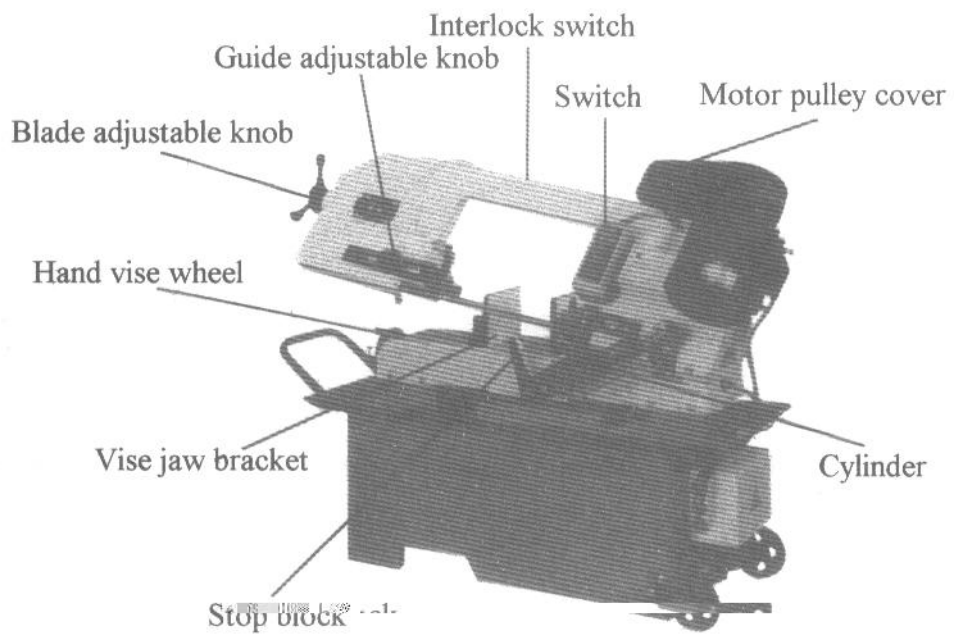

**WARNING: FAILURE TO FOLLOW THESE RULES  
MAY RESULT IN SERIOUS PERSONAL INJURY**

As with all machinery there are certain hazards involved with operation and use of the machine. Using the machine with respect and caution will considerably lessen the possibility of personal injury. However, if normal safety precautions are overlooked or ignored, personal injury to the operator may result.

This machine was designed for certain applications only. We strongly recommend that this machine NOT be modified and/or used for any application other than for which it was designed. If you have any questions relative to its application DO NOT use the machine until you contact with us and we have advised you.

**You machine might not come with a power socket or plug. Before using this machine, please do ask your local dealer to install the socket or plug on the power cable end.**

**SAFETY RULES FOR ALL TOOLS**

**A. USER:**

- (1). **WEAR PROPER APPAREL.** No loose clothing, gloves, rings, bracelets, or other jewelry to get caught in moving parts.
- (2). **ALWAYS WEAR EYE PROTECTION.** Refer to ANSLZ87.1 standard for appropriate recommendations.  
Also use face dust mask if cutting operation is dusty.
- (3). **DON'T OVERREACH.** Keep proper footing and balance at all times.
- (4). **NEVER STAND ON TOOL.** Serious injury could occur if the tool is tipped or if the cutting tool is accidentally contacted.
- (5). **NEVER LEAVE TOOL RUNNING UNATTENDED. TURN POWER OFF.** Don't leave tool until it comes to a complete stop.

- (6). **DRUGS, ALCOHOL, MEDICATION.** Do not operate tool while under the influence of drug, alcohol or any medication.
- (7). **MAKE SURE TOOL IS DISCONNECTED FROM POWER SUPPLY.** While motor is being mounted, connected or reconnected.
- (8). **ALWAYS** keep hands and fingers away from the blade.
- (9). **STOP** the machine before removing chips.
- (10). **SHUT-OFF** power and clean the **BAND SAW** and work area before leaving the machine.

#### **B. USE OF MACHINE:**

- (1). **REMOVE ADJUSTING KEYS AND WRENCHES.** Form habit of checking to see that keys and adjusting wrenches are removed from tool before turning it “on”.
- (2). **DON'T FORCE TOOL.** It will do the job better and be safer at the rate for which it was designed.
- (3). **USE RIGHT TOOL.** Don't force tool or attachment to do a job for which it was not designed.
- (4). **SECURE WORK.** Use clamps or a vise to hold work when practical. It's safer than using your hand frees both hands to operate tool.
- (5). **MAINTAIN TOOLS IN TOP CONDITION.** Keep tools sharp and clean for best and safest performance. Follow instructions for lubricating and changing accessories.
- (6). **USE RECOMMENDED ACCESSORIES.** Consult the owner's manual for recommended accessories. The use of improper accessories may cause hazards.
- (7). **AVOID ACCIDENTAL STARTING.** Make sure switch is in “**OFF**” position before plugging in power cord.
- (8). **DIRECTION OF FEED.** Feed work into a blade or cutter against the

direction of rotation of the blade or cutter only.

(9). **ADJUST AND POSRTION** the blade guide arm before starting the cut.

(10). **KEEP BLADE GUIDE ARM TIGHT**, A loose blade guide arm will affect sawing accuracy.

(11). **MAKE SURE** blade speed is set correctly for material being cut.

(12). **CHECK** for proper blade size and type.

(13). **STOP** the machine before putting material in the vise.

(14). **ALWAYS** have stock firmly clamped in vise before starting cut.

(15). **GROUNDALL TOOLS**. If tool is equipped with three-prong plug, it should be plugged into a three-hole electrical receptacle. If an adapter is used to accommodate atwoprong receptacle, the adapter lug must be attached to a known ground. Never removed the third prong.

### **C.ADJUSTMENT:**

MAKE all adjustments with the power off. In order to obtain the machine precision and correct ways of adjustment while assembling, the user should read detailed instruction in this manual.

### **D.WORKING ENVIRONMENT:**

(1). **KEEP WORK AREA CLEAN**. Cluttered areas and benches invite accidents.

(2). **DON'T USE IN DANGEROUS ENVIRONMENT**. Don't use power tools in damp or wet locations, or expose them to rain. Keep work area well-lighted.

(3). **KEEP CHILEREN AND VISITIORS AWAY**. All children and visitors should be kept a safe distance from work area.

(4). **DON'T** install & use this machine in explosive, dangerous

environment.

## **E. MAINTENANCE**

- (1). **DISCONNECT** machine from power source when making repairs.
- (2). **CHECK DAMAGED PARTS.** Before further use of the tool, a guard part that is damaged should be carefully checked to ensure that it will operate properly and perform its intended function check for alignment of moving parts, binding of moving parts, breakage of parts, mounting, and any other conditions that may affect its operation. A guard or other part that is damaged should be properly repaired or replaced.
- (3). **DISCONNECT TOOLS** before servicing and when changing accessories such as blades, bits, cutters, etc.
- (4). **MAKE SURE** that blade tension and blade tacking are properly adjusted.
- (5). **RE-CHECK** blade tension after initial cut with a new blade.
- (6). **TO PROLONG BLADE LIFE ALWAYS** release blade tension at the end of each work day.
- (7). **CHECK COOLANT DAILY** . Low coolant level can cause foaming and high blade temperatures. Dirty or weak coolant can clog pump, cause crooked. Cast low cutting rate and permanent blade failure. Dirty coolant can cause the growth of bacteria with ensuing skin irritation.
- (8). **WHEN CUTTING MAGNESIUM NEVER** use soluble oils or emulsions (oil-water mix) as water will greatly intensify any accidental magnesium chip fire. See your industrial coolant supplier for specific coolant recommendations when cutting magnesium.
- (9). **TO PREVENT** corrosion of machined surfaces where a soluble one is used as coolant, pay particular attention on wiping dry the surfaces where fluid accumulates and does not evaporate quickly, such as between the

machine bed and vise.

**F. SPECTIFIED USAGE:**

This machine is used only fir general cutting within the range of cutting capacity.

**G. NOISE**

A weighted sound pressure level: 80 dB

**H. SAFETY DEVICE:**

By the time the saw arm cover is opened, the interlock switch will function to stop the machine, do not remove this switch from machine for any reason, and check its function frequently.

**1. SPECIFICATION**

MOTOR		3 $\phi$ 0.75KW(1HP) 1 $\phi$ 1.1KW(1-1/2HP)			
Saw Blade Speed (MPM)	912G. 912GDR	60HZ	38 78 115	50HZ	31 65 95
	912B7	60HZ	32 60 88 115	50HZ	26 50 73 95
	912DR	60HZ	32 60 88 115	50HZ	26 50 73 95
Saw Blade Speed (FPM)	912G. 912GDR	60HZ	125 255 380	50HZ	104 212 316
	912B	60HZ	105 196 288	50HZ	85 164 240 312
			3 7 7		
912DR	60HZ	105 196 288	50HZ	85 164 240 312	
			3 7 7		
Blade Size		27x0.9x2655mm/1"x0.035"x104.5"			
Dimension LxWxH(mm)		1325x630x1050(G) 1380x460x1050(B) 1350x650x1100 (DR.GDR)			
N.W/G.W(kgs)		155/180(G..DR.GDR) 140/165(B)			
Working Capacity	0°	○(mm)	230(9")		
		□(mm)	178x305x(7"x12")(G.B)127x300(5"x12")(DR.GDR)		
	±45°	○(mm)	150(6")(G.B) 165(6-1/2")(DR. GDR)		
		□(mm)	127x150(5"x6")(G.B) 100x200(4"x8")(DR.GDR)		

Packing Measurement(mm) LxWxH	1420x690x1100(G) 1420x530x1100(B) 1450x740x1140(DR.GDR)
Overall height (w/o stand)	1600mm(63")
Noise	80dB MAX

## 2. TRANSPORTATION OF MACHINE:

### Unpacking

1. Transportation to desired location before unpacking, please use lifting jack. (Fig. B)

2. Transportation after unpacking, please use heavy duty fiber belt to lift p the machine.



Fig. B

**ALLWAYS KEEP PROPER FOOTING &BALANCE WHILE MOVING THIS MACHINE.**

As this machine weight 155kg. It is recommended that the machine shall be transported, with help of lifting jack.

Transportation Recommendation:

(1). Tighten all locks before operation.

(2). Always Keep proper footing & balance while moving this 155kgs machine, and only use heavy duty fiber to lift the machine as Fig. A

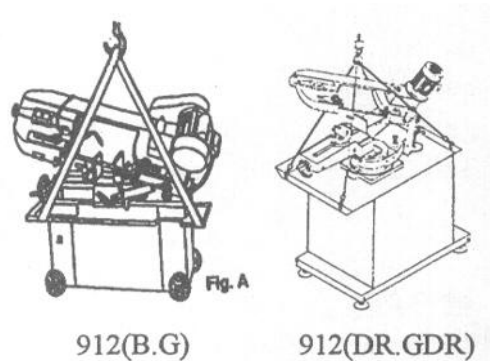

(3). **TURN OFF** the power before wiring, &be sure machine in proper grounding, overload & circuit breaker is recommended for safety wiring.



(4). **CHECK** carefully if the saw blade is dunning in counter-clockwise direction in not, reverse the wiring per circuit diagram the repeat the running test.

(5). **KEEP** machine always out from sun, dust, wet, raining area.

## 6. MINIMUM ROOM SPACE FOR MACHINE OPERATION

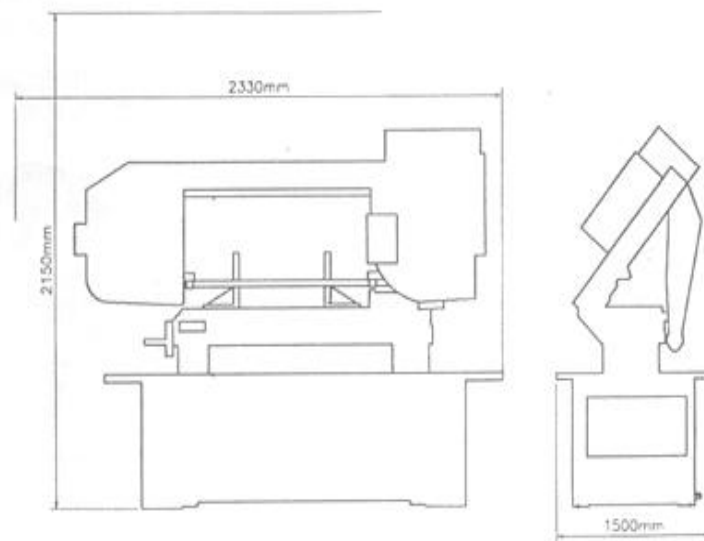

## 7. MAKE PROPER TOOTH SELECTION

For maximum cutting efficiency and lowest cost pre cut, it is important to select the blade with the right number of teeth per inch (TPI) for the material being cut. The material size and shape dictate tooth selection.

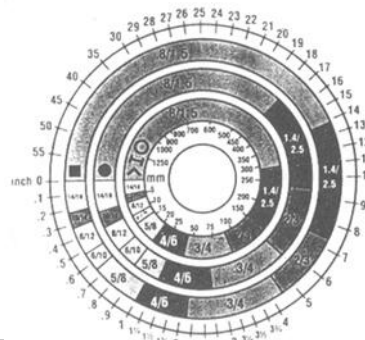

### TOOTH SELECTION

You need to consider

1. The width of the cut. That is the distance in the cut that each tooth must travel from the point it enters the workpiece until it leaves the workpiece.

2. The shape of the workpiece.

● **Squares, Rectangles, Flats (Symbol :■)**

Locate the width of cut on the chart. (Inches on the outer circle and millimeters on the inner circle.) Select the tooth pitch on the ring marker with the square shape which aligns with the width of cut.

EXAMPLE: 6” (150mm) square, use a 2/3 Vari-Tooth.

● **Round Solids (Symbol :●)**

Locate the diameter of your workpiece on the chart. Select the tooth pitch on the ring marked with the round shape which aligns with the size of stock you are cutting.

EXAMPLE: 4” (100mm) round, use a 3/4 Vari-Tooth.

● **Tubing, Pipe, Structural (Symbol: O H ^ )**

Determine the average width of cut by dividing the area of the workpiece by the distance the saw blade must travel to finish the cut.

Locate the average width of cut on the chart. Select the tooth Ditch on the ring marked with the tubing and structural shape which aligns with the average width you are cutting.

EXAMPLE: 4” (100mm) outside diameter, 3”(75mm) inside diameter tubing.

$$\begin{array}{r} 4'' (100\text{mm}) \text{ OD} = 12.5 \text{ sq.In. } (79\text{c m}^2) \\ \hline 3'' (75\text{mm}) \text{ I D} = 7.0 \text{ sq.In. } (44\text{c m}^2) \\ \hline \text{Area} = 5.5 \text{ sq.In. } (35\text{c m}^2) \end{array}$$

5.5 sq.In. (35c m<sup>2</sup>)/4” (100mm) distance =1.38(35mm) average width  
1.38” (35mm), use a 4/6 Vari- Tooth

**NOTE:** The band speed and cutting rate recommendations presented on this chart are approximations and are to be used as a starting point for most applications. For exact sawing parameters’ consult your saw blade

supplier.

## 8. BI-METAL SPEEDS AND FEEDS

These figures are a guide to cutting 4”(100mm) material (with a 314 Vari-tooth when using a cutting fluid.

Increase Band Speed:

15% When cutting 1/4” (6.4mm) material (10/14 Vari-Tooth)

12% When cutting 3/4” (19mm) material ( 6/10 Vari-Tooth )

10% When cutting 1-1/4” (32mm) material ( 5/8 Vari-Tooth )

5% When cutting 2-1/2” (64mm) material ( 4/6 Vari-Tooth )

Decrease Band Speed:

12% When cutting 8” (200mm) material ( 2/3 Vari-Tooth )

MATERIAL	ALLOY ASTM NO	BAND SPEED	
		FT./MIN	M/MIN
Copper Alloy	173,932	314	96
	330,365	284	87
	623,624	264	81
	230,260,272	244	74
	280,264,632,655	244	74
	101,102,110,122,172	234	71
	1751,182,220,510	234	71
	625,706,715,934	234	71
	630	229	70
	811	214	65
Carbon Steel	1117	339	103
	1137	289	88

	1141,1144	279	85
	1141HI STRESS	279	85
	1030	329	100
	1008,1015,1020,1025	319	97
	1035	309	94
	1018,1021,1022	299	91
	1026,1513	299	91
	A36 (SHAPES),1040	269	82
	1042,1541	249	76
Carbon Steel	1044,1045	219	67
	1060	199	61
	1095	184	56
Ni-Ci-Mo Alloy Steel	8615,86120,8622	239	73
	4340,E4340,8630	219	67
Ni-Ci-Mo Alloy Steel	8640	199	61
	E9310	174	53
Tool Steel	A-6	199	61
	A-2	179	55
	A-10	159	49
	D-2	90	27
	H-11,H-12,H-13	189	58
Stainless Steel	420	189	58
	430	149	46
	410,502	140	43
	414	115	35
	431	95	29

	440C	80	24
	304,324	120	36
	304L	115	35
	347	110	33
	316,316L	100	30
	416	189	58

### TELLTALE CHIPS

Chips are the best indicator of correct feed force. Monitor chip information and adjust feed accordingly.

Thin or powdered chips-increase feed rate or reduce band speed.



Burned heavy chips-reduce feed rate and/or band speed.



Curly silvery and warm chips-optimum feed rate band speed.



### 9. ASSEMBLY

A 1 HP, motor, split phase or capacitor-start it recommended for best economical performance. Counterclockwise rotation is required. Note that rotation can be reversed by following directions given on terminal nameplate.

- (1). Assemble the motor Mounting plate to the head using the long bolt  
Note that the flat side of the plate faces up.
- (2). Assemble the guard plate to the head using the screw and Lock Washer and the Carriage Bolt Washer and Wing Nut are used to secure the motor mounting plate to the Guard plate through the slotted hole in the Guard plate. These components also serve to position and lock the motor in place for proper speed/ belt adjustment.
- (3). Place the spacer over the long Bolt and secure it with the nut.
- (4). Secure the Motor to the Motor Mounting plate with the four bolts and nuts. Note that the motor shaft is placed through the large opening in the Guard plate and must be parallel with the drive Shaft.
- (5). Assemble the Motor Pulley, the smaller of the two provided, to the motor shaft Note, the larger diameter must be closest to the motor. Do not tighten the set screw.
- (6). Assemble the Driven Pulley, the larger of the two provided, to the protruding drive Shaft Note the small diameter must be closest to the bearing. Do not tighten the set screw.
- (7). Place the belt into one of the pulley grooves and the other end into the respective grooves of the second pulley.
- (8). Line up the belt and both pulleys such that the belt is running parallel in the pulley grooves.
- (9). Tighten the set screws of both pulleys in this position.
- (10). Place the belt into proper pulley combination for proper blade speed. See material cutting chart.
- (11). Adjust the position of the Motor to obtain approximately 1/2" depression in the belt when applying pressure with your thumb.
- (12). Tighten the head screw Holding the Motor Mounting plate to the Guard plate.

(13). Connect the Electrical Harness to the motor terminal box. The motor should be protected with a time delay fuse or circuit breaker with rated amperage slightly greater than the full load amperage of the motor.

**10. OPERATION**

WORK SET UP

- (1). Raise the saw head to the highest position.
- (2). Open vise to accept the Piece to be cut by rotating the wheel at the end the base.
- (3). Place workpiece on saw bed. If the piece is long, support the end.
- (4). Clamp workpieced securely in vise.

WORK STOP ADJUSTMENT

- (1). Loosen the thumb screw holding the work stop casing to the shaf.
- (2). Adjust the work stop casing to the desired length position.
- (3). Rotate the work stop to as close to the bottom of the cut as possible.
- (4). Tighten thumbscrew.
- (5). DO NOT ALLOW the blade to rest on the work while the motor is shut off.

BLADE SPEEDS

When using your Band saw always change the blade speed to best suit the material being cut the material Cutting Shirt gives suggested settings for several materials.

Material	Speed F.P.M				Belt Groove Used	
	912(G.GDR)		912 (B.DR)		Motor pulley	Saw Pulley
	60Hz	50Hz	60Hz	50Hz		

Tool,Stainless Alloy Steels Bearing Bronze	125	104	105	85	small	largest
Medium to High Carbon Steels Hard Brass or Bronze	255	212	196	164	Medium	Large
Low to Medium Carbon Steel Soft Brass			288	240	Large	Medium
Aluminum Plastic	380	316	377	12	Largest	Small

### **MANUAL OF GEAR TYPE SPEED CHANGING**

- (1) Select the proper cutting speed according to the material of work-pieces and blade select chart.
- (2) Turn the speed-changing handle directly for the necessary speed.
- (3) Changing speed during cutting is prohibited.
- (4) But changing speed when machine is stopped and sunning (before cutting)

### **BALDE DIRECTION OF TRAVEL**

Be sure the Made is assembled to the pulley such that the vertical edge engages the work piece first.

#### **BLADE MOVEMENT**

BLADE MOVEMENT

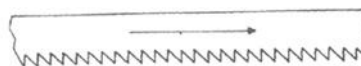

Blade Direction



## **STARTING SAW**

Switch button function description

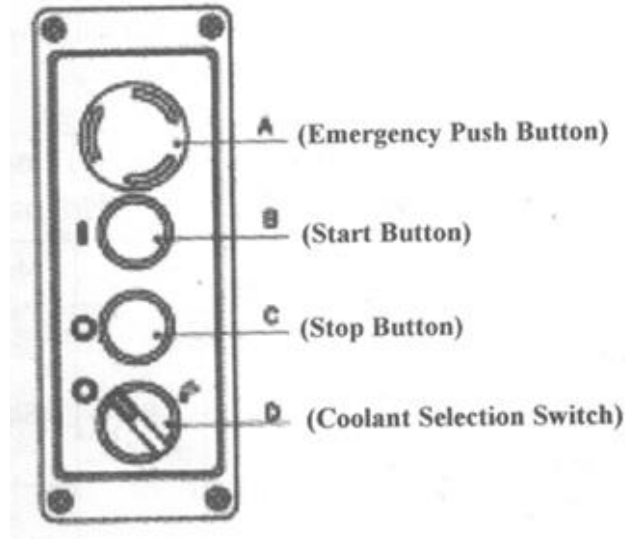

**CAUTION : NEVER OPERATE SAW WITHOUT BLADE GUARDS IN PLACE.**

Be sure the blade is not in contact with the work when the motor is started. Start the motor, allow the saw to come to full speed, and then begin the cut by letting the head down slowly onto the work. **DO NOT DROP OR FORCE.** Let the weight of the saw head provide the cutting force. The saw automatically shuts off at the end of the cut.

## **BLADE SELECTION**

A 8-tooth per inch, general-use blade is furnished with metal Cutting Band Saw. Additional blades in 4, 6, 8, and 10 tooth sizes are available. The choice of blade pitch is governed by the thickness of the work to be cut: the thinner the workpiece, the more teeth advised. A minimum of three (3) teeth should engage to workpiece at all times for proper cutting. If the teeth of the Blade are so far apart that they straddle the work, severe damage to the workpiece and to the Machine can result.

## **CHANGING BLADE**

Raise saw head to the highest position and open the blade guards. Loosen

tension screw knob sufficiently to allow the saw blade to slip off the wheels.

Install the new blade with teeth slanting toward the motor as follows:

- (1). Place the blade in between each of the guide bearings.
- (2). Slip the blade around the motor pulley (bottom) with the left hand and hold in position.
- (3). Hold the blade taut against the motor pulley by pulling the blade upward with the right hand which is placed at the top of the Made.
- (4). Remove left hand from bottom pulley and place is at the top aide of the Made to continue the application on the upward pull on the blade
- (5). Remove right hand from blade and adjust the position of the top pulley to permit left hand to slip the blade around the pulley using the thumb, index and little finger as guides.
- (6). Adjust the blade tension knob clockwise until it is just right enough so no blade slippage occurs. Do not tighten excessively.
- (7). Replace the blade guards.
- (8). Place 2-3 drops of oil on the blade.

### **TRU-LOCK VISE SYSTEM INSTRUCTIONS**

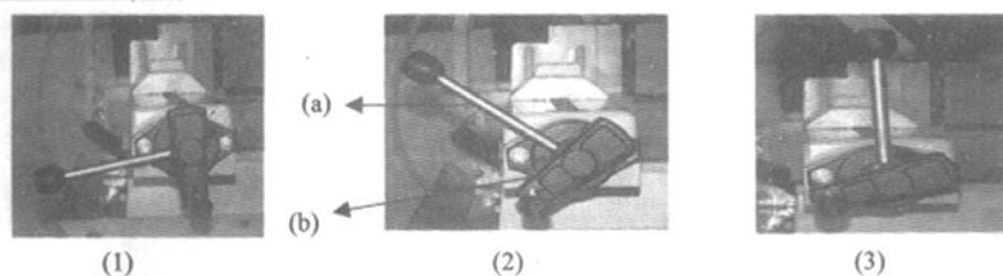

- (1). The position of the vise when tightened.
- (2). The position of the vise when loosened. (Half opened).
- (3). The position of the vise when loosened.(Completely opened).

**To operate, proceed as follows:**

- 1) Rise the arm 2" above the workpiece, close the cylinder valve to

maintain the arm 2" above the workpiece.

- 2) Put your workpiece on the table. Move the vise handle (a) upwards to an angle of 45 degree (a-half opened) to loosen the vise. Move the vise jaw bracket against the workpiece by turning the rectangular handle (b). Push down on the vise handle (a) to lock the workpiece in position.
- 3) To loosen the workpiece from the vise, hold the workpiece and lift the vise handle (a) to a 90 degree position (completely opened). Remove workpiece.

### **QUICK VISE ADJUSTMENT FOR ANGLE CUT (912B. 912G)**

- (1). Loosen the A. B. C. D. Screw.
- (2). Adjust rear vise to the threaded hole position. (E)
- (3). Set the scale to the desired angle.
- (4). Adjust the front vise (F) to parallel the rear vise (E)
- (5). Tighten the A. B. C. D. Screw.

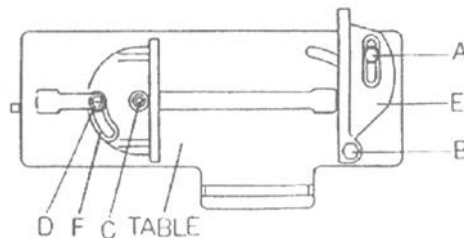

### **QUICK VISE ADJUSTMENT FOR ANGLE CUT (912DR. 912GDR)**

- (1). Pull out plastic knob (A). Turn and lock the plastic knob.
- (2). Loosen grip (B). Then rotate the Body Frame for the desired angle. Be aware the blade position is higher than the Vise Table by pulling up the Body Frame when count-clockwise rotation for angle cutting and for clockwise rotation for angle cutting higher the Body Frame and keep the blade position higher than the vise. Then pull forward the vise Jaw Bracket (Front) to a proper

location.

(3). Fasten the grip (B) when the cutting angle is reached.

(4). There is angle set-screw for  $\pm 45^\circ$  rotation.

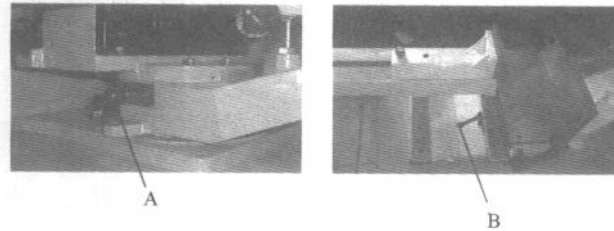

## 11. BLADE GUIDE BEARING ADJUSTMENT

**ATTENTION:** This is the most important adjustment on your saw. It is impossible to get satisfactory work from your saw if the blade guides are not properly adjusted. The blade guide bearing on your metal. Cutting Band Saw are adjusted and power tested with several test cuts before leaving the factory to insure proper setting. The need for adjustment should rarely occur straight, and if the situation is not corrected it will cause serious blade damage. Because guide adjustment is a critical factor in the performance of your saw, it is always best to try a new blade to see if this will correct poor cutting before beginning to adjust. If a blade becomes dull on one side sooner than the other, for example, it will begin cutting crooked. A blade change will correct this problem the guide adjustment will not. If a new blade does not correct the problem, check the blade guides for proper spacing.

**NOTE:** There should be from 000(just touching) 001 clearance between the blade and guide bearings to obtain this clearance adjust as follows:

1. The inner guide bearing is fixed and cannot be adjusted.
2. The outer guide bearing is mounted to an eccentric bushing and can be adjusted.
3. Loosen the nut while holding to an eccentric bushing and can be

adjusted.

4. Position the eccentric by turning the bolt to the desired position of clearance.
5. Tighten the nut.
6. Adjust the second blade guide bearing in the same manner.

**REMARK:**

1. Adjust the tension of blade until the back of the blade (A) against the blade wheel (front) lightly.
2. Be sure the nut (E) is tightened.
3. Turn the eccentric shaft (B) counterclockwise, when the bearing (D) touches the saw blade properly, tighten the nut (E).
4. To adjust, loosen set screw (F) and move the blade adjustable up or down until it lightly touches the back of the blade (A).
5. The carbide blade guides (L) Fig.1, should also be adjusted so they lightly touch the blade by loosening screws (M).
6. Repeat 1, 2, 3,4and 5 steps to adjust the other side's blade guide bearings (G).
7. Correct the base and blade to be a vertical position with a scale. If necessary, loosen set screw (F).
8. Set down the blade frame, correct the jaw vise (H) and blade to be a vertical position with a scale then tighten the set screws (I)
9. Loosen set screw 9K), move front jaw vise (J) to against rear jaw vise (H) tightly. Finish correcting by tightening set screw (K).

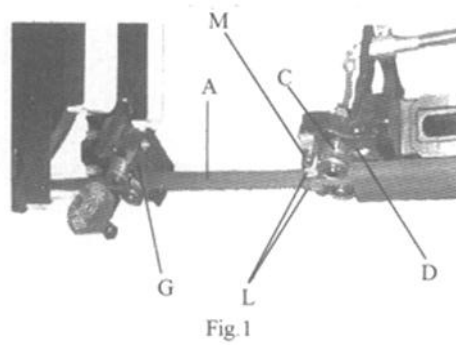

Fig.1

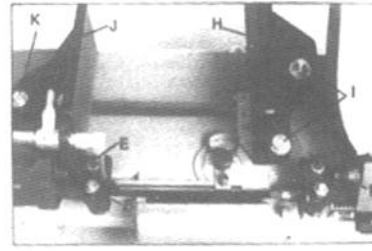

Fig.2

## 12. BLADE TRACK ADJUSTMENT

- (1). Open the blade guard.
- (2). Remove the blade guide assemblies (top and bottom).
- (3). Loosen the hex head screw in the tilting mechanism to a point where it is loosen but snug.
- (4). With the machine running, adjust both the set crew and blade tension knob simultaneously to keep constant tension on the blade. The set screw and blade tension knob are always turned in opposite directions, ie, when one is turned clockwise the other is turned counterclockwise. The blade is tracking properly when the back side just touches the shoulder of pulley or a slight gap appears near the center line of the pulley. Care should be taken not to over-tighten the saw blade since this will give a false adjustment and limit life of the blade.
- (5). Tighten the hex head screw in tilting mechanism. **IMPORTANT:** Sometimes in trying to make this critical adjustment it is possible to cause the basic setting to be misaligned. Should this occur, proceed as follows:
  - a. Loosen the set screw and back it out as far as it can go and still remain in the threaded hole.
  - b. Turn the hex head screw clockwise until it stops (do not tighten).
  - c. Turn the set screw clockwise until it bottoms, then continue for

half a turn and check the tracking by turning on the machine.

d. if further adjustment is required, go back to step 4.

- (6). Turn off power to the machine.
- (7). Replace the blade guide assemblies--it may be necessary to loosen the blade tension slightly.
- (8). Adjust the vertical position of blade guide bearing assemblies so that the back side of the blade just touches the ball bearing.
- (9). Make a final run to check tracking. If required, touch up adjustment (see step 4)
- (10). Replace the blade guards.

### **Hydraulic Feed Adjustment**

- (1). To adjust the feeding rate when in cutting. Turn the volume valve (A) clockwise for faster feeding.
- (2). When cutting feed is too fast, raise the saw arm, then slow the feed rate to prevent blade damage.

### **13. MAINTENANCE**

CAUTION: MAKE CERTAIN THAT UNIT IS DISCONNECTED FROM THE POWER SOURCE BEFORE ATTEMPTING TO SERVICE OR REMOVE ANY COMPONENT.

That's easier to keep machine in good condition or best performance by means of maintaining it at any time than remedy it after it is out of order.

- (1). Daily Maintenance (by operator)
  - (a) Fill the lubricant before starting machine everyday.
  - (b) If the temperature of spindle caused over-heating or strange noise, stop machine immediately to check it for keeping accurate performance.
  - (c) Keep work area clean; release vise, cutter, work-piece from table; switch off power source; take chip or dust away from machine and

follow instructions lubrication or coating rust proof oil before leaving.

(2). Weekly Maintenance

- (a) Clean and coat the leading screw been loose.
- (b) Check to see if sliding surface and turning parts lack of lubricant. If the lubricant is insufficient, fill it.

(3). Monthly Maintenance

- (a) Check if the fixed portion have been loose.
- (b) Lubricate bearing, worm, and worm shaft to avoid the wearing.

(4). Yearly Maintenance

- (a) Adjust table to horizontal position for maintenance of accuracy.
- (b) Check electric cord, plugs, switches at least once a year to avoid loosening or wearing.

#### **14. LUBRICATION**

Lubricate the following components using SAE-30 oil as noted.

- (1). Ball-bearing none.
- (2). Driven pulley bearing 6-8 drop a week.
- (3). Vise lead screw as needed.
- (4). The drive gears run in an oil bath and will not require a lubricant change more often than once a year, unless the lubricant is accidentally contaminated or a leak occurs because of improper replacement of the gear box cover. During the first few days of operation, the worm gear drive will run hot. Unless the temperature exceeds 200F, there is no cause for alarm.

The following lubricants may be used for-the gear box:

Atlantic Refinery Co. Mogul Cyl. Oil

Cities Service Gptimus No.6

Gulf Refinery Co Medium Gear Oil



## 15. TROUBLE SHOOTING

Symptom	Possible Cause(s)	Corrective Action
Excessive Blade Breakage	<ol style="list-style-type: none"> <li>1. Materials loosen in vise.</li> <li>2. Incorrect speed or feed</li> <li>3. Blade teeth spacing too large</li> <li>4. Material too coarse</li> <li>5. Incorrect blade tension</li> <li>6. Teeth in contact with material before saw is started</li> <li>7. Blade rubs on wheel flange</li> <li>8. Miss-aligned guide bearings</li> <li>9. Blade too thick</li> <li>10. Cracking at weld</li> </ol>	<ol style="list-style-type: none"> <li>1. Clamp work securely</li> <li>2. Adjust speed or feed</li> <li>3. Replace with a small teeth spacing blade</li> <li>4. Use a blade of slow speed and small teeth spacing</li> <li>5. Adjust to where blade just does not slip on wheel</li> <li>6. Place blade in contact with work after motor is started</li> <li>7. Adjust wheel alignment</li> <li>8. Adjust guide bearings</li> <li>9. Use thinner blade</li> <li>10. Weld again, note the weld skill</li> </ol>
Premature Blade Dulling	<ol style="list-style-type: none"> <li>1. Teeth too coarse</li> <li>2. Too much speed</li> <li>3. Inadequate feed pressure</li> <li>4. Hard spots or scale on material</li> <li>5. Work hardening of material</li> <li>6. Blade twist</li> <li>7. Insufficient blade</li> <li>8. Blade slide</li> </ol>	<ol style="list-style-type: none"> <li>1. Use finer teeth</li> <li>2. Decrease speed</li> <li>3. Decrease spring tension on side of saw</li> <li>4. Reduce speed, increase feed pressure</li> <li>5. Increase feed pressure by reducing spring tension</li> <li>6. Replace with a new blade, and adjust blade tension</li> <li>7. Tighten blade tension adjustable knob</li> <li>8. Tighten blade tension</li> </ol>

Unusual Wear on Side/Back of Blade	<ol style="list-style-type: none"> <li>1. Blade guides worn</li> <li>2. Blade guide bearing not adjust properly</li> <li>3. Blade guide bearing bracket is loose</li> </ol>	<ol style="list-style-type: none"> <li>1. Replace</li> <li>2. Adjust as per operators manual</li> <li>3. Tighten</li> </ol>
Teeth Ripping from Blade	<ol style="list-style-type: none"> <li>1. Tooth too coarse for work</li> <li>2. Too heavy pressure; too slow speed</li> <li>3. Vibrating work-piece</li> <li>4. Gullets loading</li> </ol>	<ol style="list-style-type: none"> <li>1. Use finer tooth blade</li> <li>2. Decrease pressure; increase speed</li> <li>3. Clamp work piece securely</li> <li>4. Use coarser tooth blade or brush to remove chips</li> </ol>
Motor running too hot	<ol style="list-style-type: none"> <li>1. Blade tension too high</li> <li>2. Drive belt tension too high</li> <li>3. Blade is too coarse for work</li> <li>4. Blade is too fine for work</li> <li>5. Gears aligned improperly</li> <li>6. Gears need lubrication</li> <li>7. Cut is binding blade</li> </ol>	<ol style="list-style-type: none"> <li>1. Reduce tension on blade</li> <li>2. Reduce tension on drive belt</li> <li>3. Use finer blade</li> <li>4. Use coarse blade</li> <li>5. Adjust gears so that worm is in center of gear</li> <li>6. Check oil path</li> <li>7. Decrease reed anti speed</li> </ol>
Bad Cuts (Crooked)	<ol style="list-style-type: none"> <li>1. feed pressure too great</li> <li>2. Guide bearings not adjusted properly</li> <li>3. Inadequate blade tension</li> <li>4. Dull blade</li> <li>5. Speed incorrect</li> <li>6. Blade guides spaced out too much</li> </ol>	<ol style="list-style-type: none"> <li>1. Reduce pressure by increasing spring tension on side of saw</li> <li>2. Adjust guide bearing, the clearance can't greater than 0.001</li> <li>3. Increase blade tension by adjust blade tension</li> <li>4. Replace blade</li> <li>5. Adjust speed</li> <li>6. Adjust guides space</li> </ol>

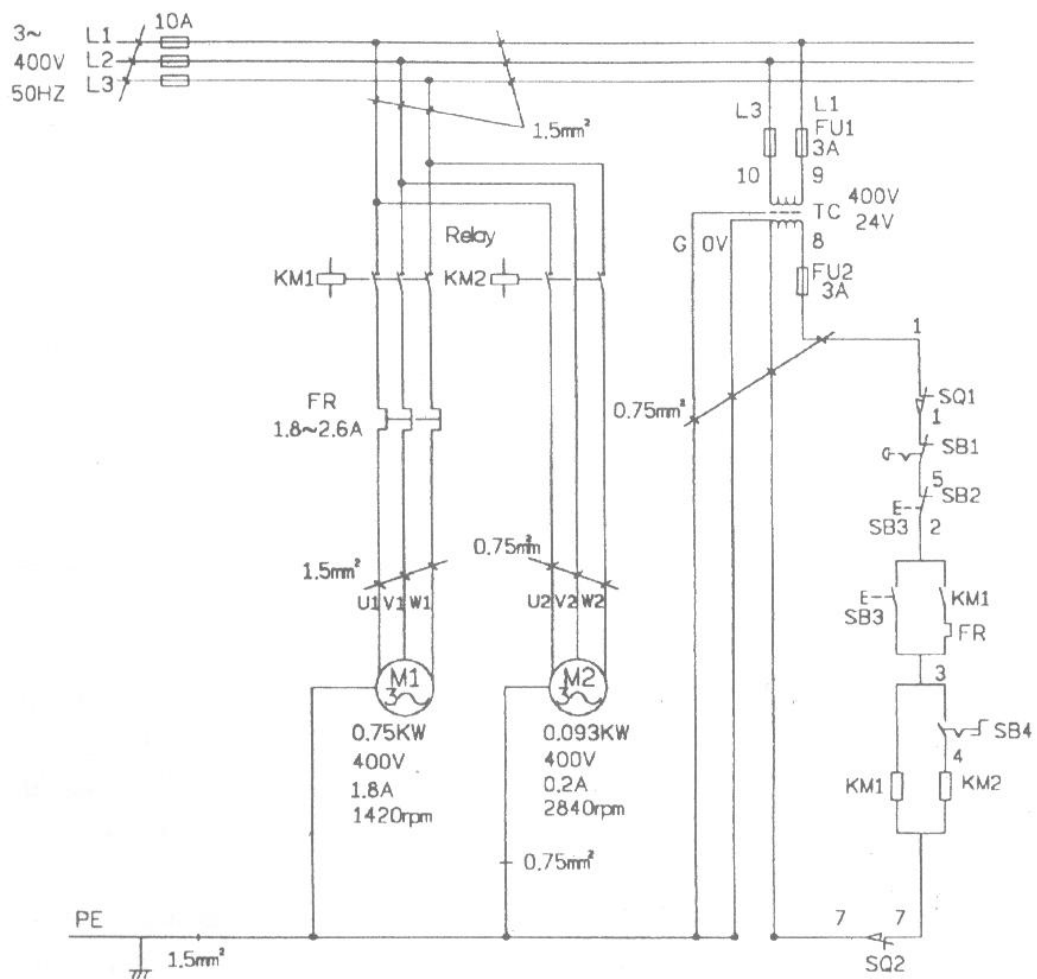

	7. Blade guide assembly loose 8. Blade truck too far away from wheel flanges	7. Tighten 8. Re-track blade according to operating instructions.
Bad Cuts (Rough)	1. Too much speed or feed 2. Blade is too coarse 3. Blade tension loose	1. Decrease speed or feed 2. Replace with finer blade 3. Adjust blade tension
Blade is twisting	1. Cut is binding blade 2. Too much blade	1. Decrease reed pressure 2. Decrease blade tension

### CIRCUIT DIAGRAM





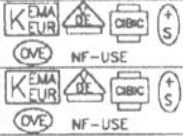

## ELECTRICAL SPECIFICATION

912		SCHEDULE OF ELECTRICAL EQUIPMENT			Sheet:	
Item	Designation and function	Technical data	QTY	Supplier	Supplier reference	REMARK
SQ1	LIMIT SWITCH	AC15 2A/400V	1	TELEMECA- NIQUE  OMRON	D4D-1532N	IEC947-5-1
SQ2	LIMIT SWITCH	AC15 2A/400V	1	TELEMECA- NIQUE  OMRON	D4D-1562N	IEC947-5-1
SB1	EMERGENCY STOP	TE XB2-ES542	1	TE		
SB2	POWER OFF	TE XB2-EA142R	1	TE		
SB3	POWER ON	TE XB2-EA131G	1	TE		
SB4	PUMP POWER ON	TE XB2-E021	1	TE		
KM1	CONTACTOR	1 $\frac{1}{2}$ -20A V $\frac{1}{2}$ 690V	1	TELEMECA- NIQUE	LC1 K0910B7	IEC NF C VDE BS 947 63110 0660 5424
KM2	RELAY	12A 300VAC	1	SOHRACH		
FR	OVERLOAD RELAY	1.8~2.6A	1	TELEMECA- NIQUE	LR2	IEC947-4-1
FU1	FUSE	3A	2	WAGO		
FU2	FUSE	3A	1	WAGO		
TC	TRANSFORMER	400V/24V 20VA	1	WAGO	SC-TRA	
M1	MOTOR	0.75KW 400V 1.8A 1420rpm	1	CHU TA	JEF-H	
M2	PUMP	0.093KW 400V 0.2A 2840rpm	1	CHU TA	JEF-VPP	
	CABLE FOR MAIN MOTOR	H05VV-F 4x1.5mm <sup>2</sup>	1	I-SHENG	H05VV-F	
	CABLE FOR COOLANT PUMP MOTOR	H05VV-F 4x0.75mm <sup>2</sup>	1	I-SHENG	H05VV-F	
	BOX		1	RONG FU		

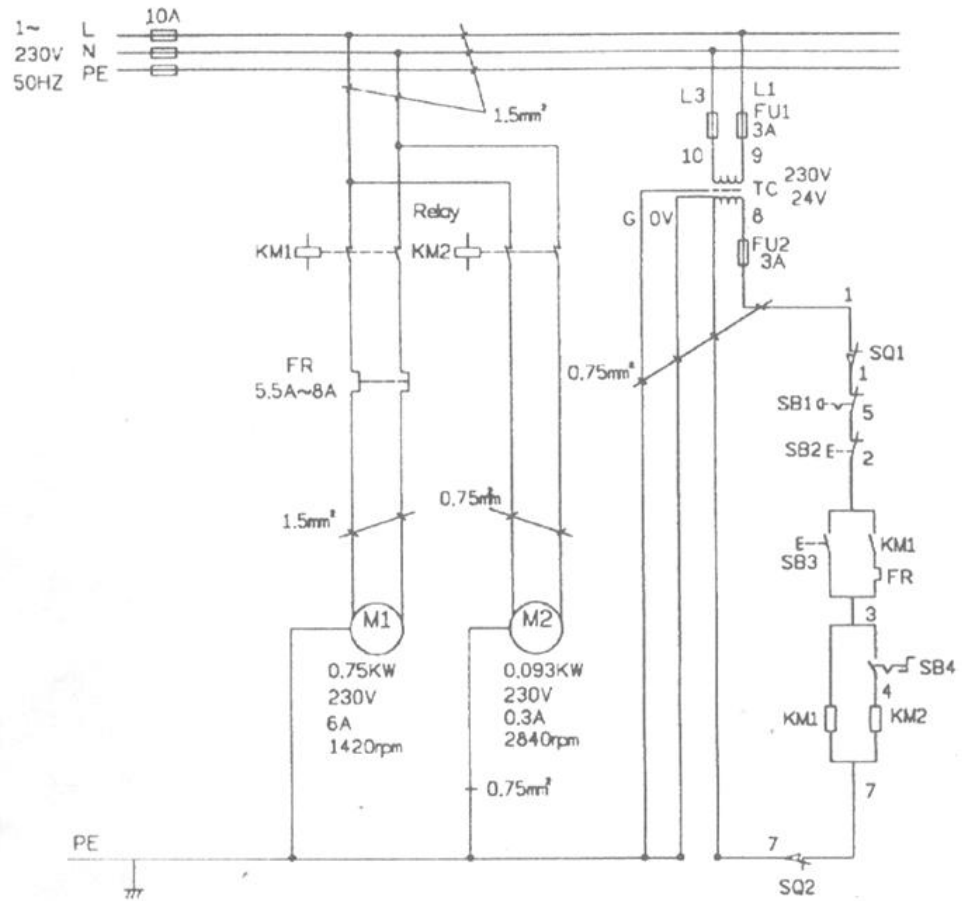
# CIRCUIT DIAGRAM



## ELECTRICAL SPECIFICATION

		SCHEDULE OF ELECTRICAL EQUIPMENT			Sheet:	
Item	Designation and function	Technical data	QTY	Supplier	Supplier's reference	REMARK
SQ1	LIMIT SWITCH	AC15 2A/400V	1	TELEMECA-NIQUE OMRON	D4D-1532N	IEC947-5-1
SQ2	LIMIT SWITCH	AC15 2A/400V	1	TELEMECA-NIQUE OMRON	D4D-1582N	IEC947-5-1
SB1	EMERGENCY STOP	TE XB2-ES542	1	TE		
SB2	POWER OFF	TE XB2-EA142R	1	TE		
SB3	POWER ON	TE XB2-EA131G	1	TE		
SB4	PUMP POWER ON	TE XB2-E021	1	TE		
KM1	CONTACTOR	Ith=20A V1890V	1	TELEMECA-NIQUE	LC1 K0910B7	IEC NF C VDE BS 947 63110 0660 5424
KM2	RELAY	12A 300VAC	1	SCHRACH		
FR	OVERLOAD RELAY	5.5A~6A	1	TELEMECA-NIQUE	LR2	IEC947-4-1
FU1	FUSE	3A	2	WAGO		
FU2	FUSE	3A	1	WAGO		
TC	TRANSFORMER	230V/24V 20VA	1	WAGO	SC-TRA	
M1	MOTOR	0.75KW 230V 6A 1420rpm	1	CHU TA	JEF-H	
M2	PUMP	0.093KW 230V 0.3A 2840rpm	1	CHU TA	JEF-VPP	
	CABLE FOR MAIN MOTOR	H05VV-F 4x1.5mm <sup>2</sup>	1	I-SHENG	H05VV-F	
	CABLE FOR COOLANT PUMP MOTOR	H05VV-F 4x0.75mm <sup>2</sup>	1	I-SHENG	H05VV-F	
	BOX		1	RONG FU		

# CIRCUIT DIAGRAM

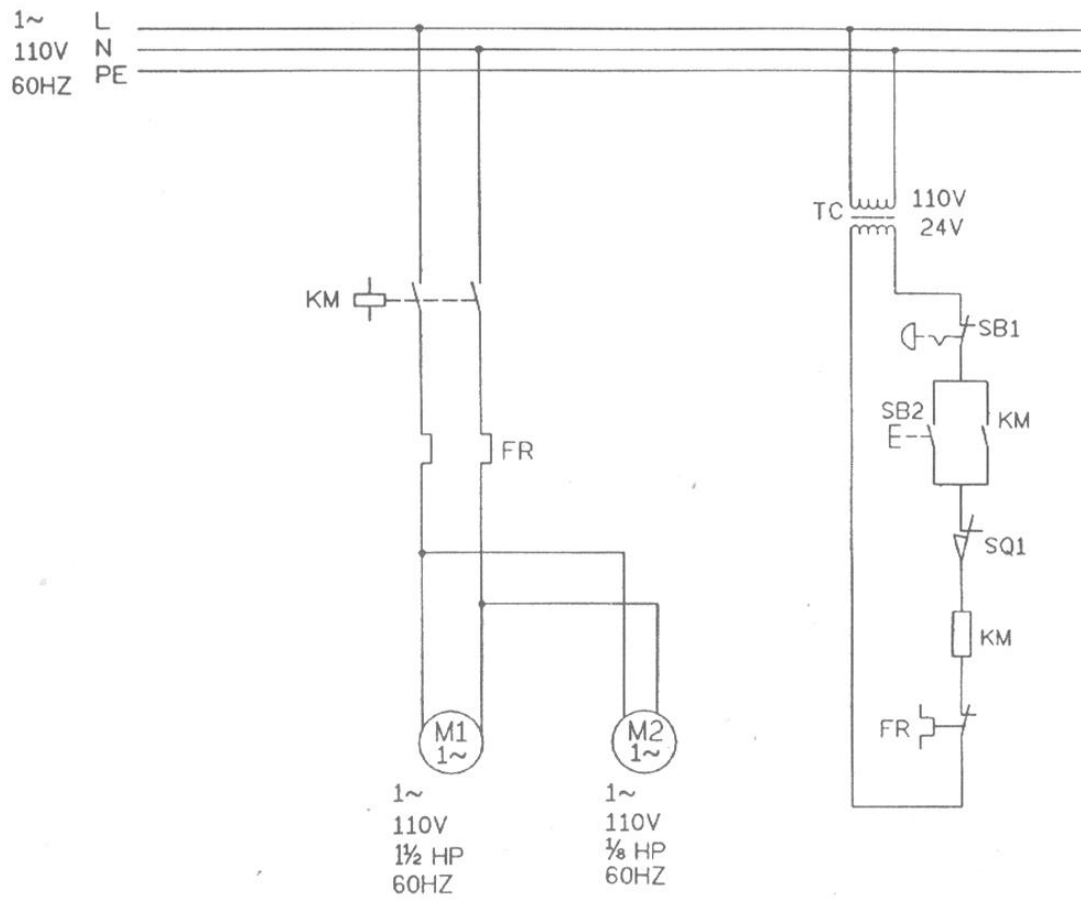

- TC : TRANSFORMER
- SB1: EMERGENCY STOP
- SB2: START SWITCH
- SQ1: LIMIT SWITCH
- KM : CONTACTOR
- FR : OVERLOAD
- M1 : MOTOR
- M2 : PUMP



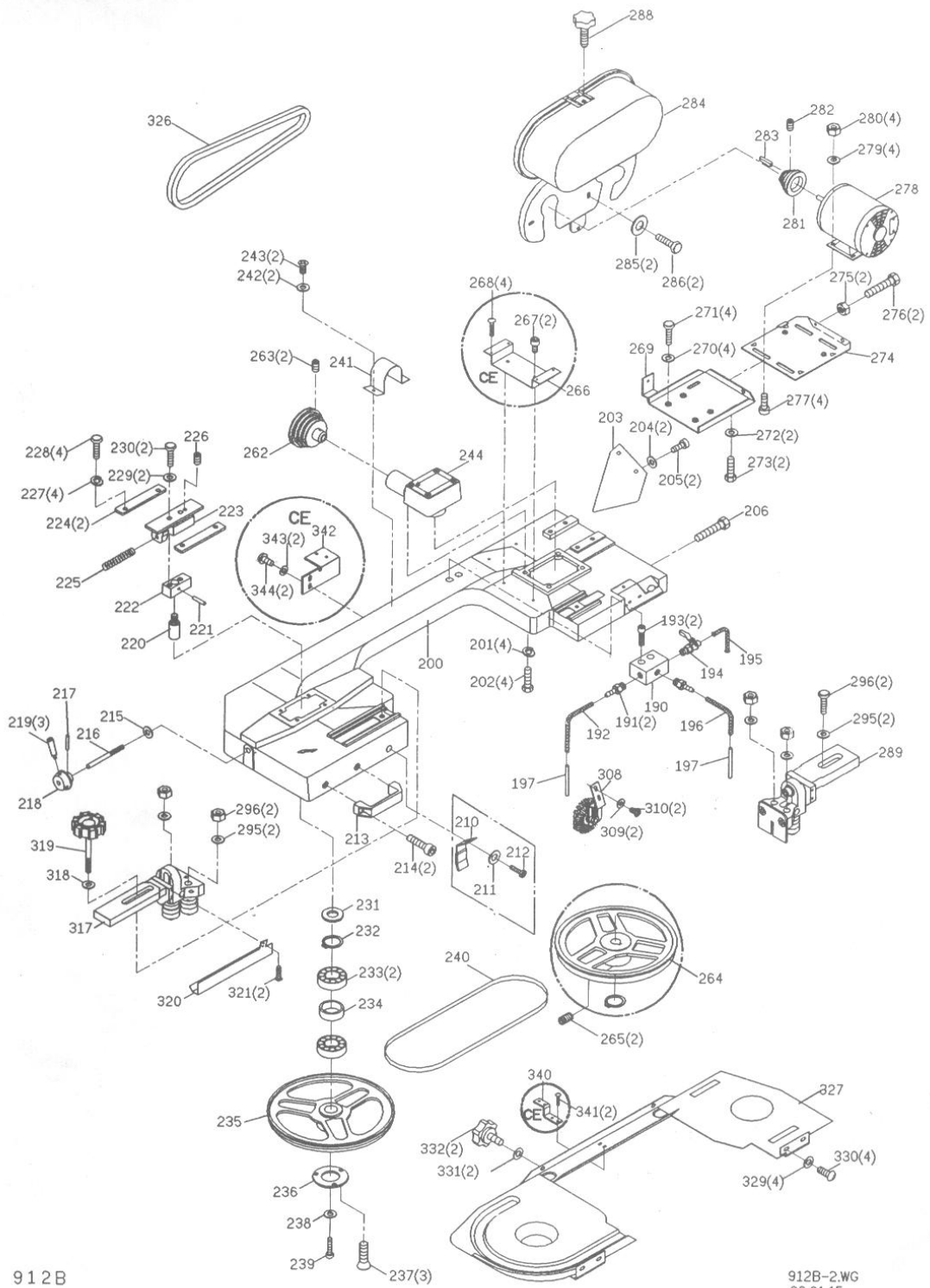

912B

912B-2.WG  
90.01.15

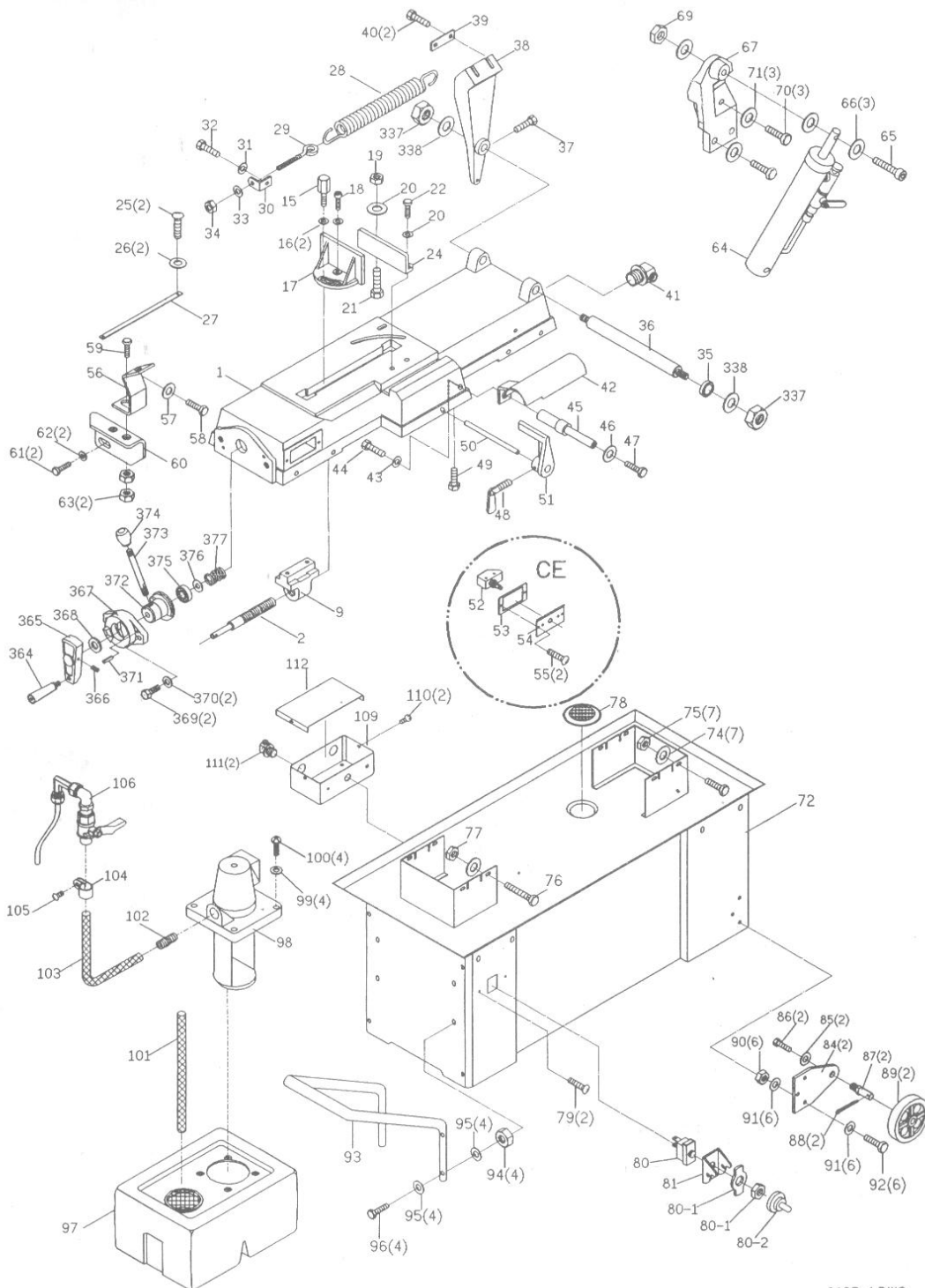

912B

912B-1DWG  
90.01.04

## MODEL NO. 912B

### PART LIST

CODE	PART NO.	DESCRIPTION	SPECIFICATION	Q'TY
1	192012A	Swivel Base		1
2	192009A	Acme Screw		1
9	1811388B	Acme Nut		1
15	181266	Fixed Bolt		1
16	W008	Spring Washer	3/8"x25xt2	2
17	192015	Vise Jaw Bracket (Front)		1
18	S410	Hex. Socket Head Screw	3/8"x1-1/2"L	1
19	N001	Hex. Nut	1/2"	1
20	W002	Spring Washer	1/2"x28xt2	2
21	S501	Carriage Screw	1/2"x2"L	1
22	S003	Hex. Head Screw	1/2"x2"L	1
24	192008	Vise Jaw Bracket (Rear)		1
25	S708	Cross Round Head Screw	3/16"x3/8"L	2
26	W007	Spring Washer	3/16"x12xt0.8	2
27	192044	Scale		1
28	181117-1	Spring		1
29	181118	Spring Adjusting Screw		1
30	192040	Spring Handle Bracket		1
31	W016	Spring Washer	5/16"x23xt2	1
32	S022	Hex. Head Screw	5.16"x3/4"L	1
33	W014	Spring Washer	3/8"x23xt2	1
34	N005	Hex. Nut	3/8"	1
35	192051	Bushing		1
36	192042A	Support Rod		1

37	S022	Hex. Head Screw	5/16"x3/4"L	1
38	192003	Pivot Bracket		1
39	181270	Washer		1
40	S012	Hex. Head Screw	3/8"x1-1/2"L	2
41	ET2108	Wire Nipple	5/8"	1
42	192033	Cylinder Protector		1
43	W018	Spring Washer	5/16"x23xt3	2
44	S022	Hex. Head Screw	5/16"x3/4"L	2
45	181301-2	Cylinder Lower Support		1
46	W016	Spring Washer	5/16"x19xt1.5	1
47	S018	Hex. Head Screw	5/16"x1/2"L	1
48	191224	Thumb Screw		1
49	S022	Hex. Head Screw	5/16"x3/4"L	1
50	3021	Stock Stop Rod		1
51	181125	Distance Set Bracket		1
52	ET1624	Limit Switch		1
53	181431	Gear Box Gasket		1
54	181420	Cover		1
55	S708	Cross Round Head Screw	3/16"x3/8"L	2
56	192011	Fixed Plate		1
57	W005	Spring Washer	1/4"x16xt1.5	1
58	S019	Hex. Head Screw	5/16"x1-1/2"L	1
59	S014	Hex. Head Screw	3/8"x3/4"L	1
60	181112A	Support Plate		1
61	S022	Hex. Head Screw	5/16"x3/4"L	2
62	W017	Spring Washer	5/16"x18xt1.5	2
63	N005	Hex. Nut	3/8"	2
64	181304-2	Cylinder Complete Set	RF-712N	1

65	S412	Hex. Socket Head Screw	3/8"x2-1/4"L	1
66	W013	Spring Washer	3/8"x20xt2	3
67	181302-2	Cylinder Upper Support		1
69	N005	Hex. Nut	3/8"	1
70	S017	Hex. Head Screw	5/16"x1"L	3
72	192045S	Stand Complete Assembly		1
73	S017	Hex. Head Screw	5/16"x1"L	7
74	W017	Spring Washer	5/16"x18xt1.5	8
75	N007	Hex. Nut	5/16"	7
76	S013	Hex. Head Screw	3/8"x1-1/4"L	1
77	N005	Hex. Nut	3/8"	1
78	191106A	Filter		1
79	S708	Cross Round Head Screw	3/16"x3/8"L	2
80	ET1401	Toggle Switch		1
81	3131	Switch Cover		1
82	181932	Toggle Switch Cover		1
84	192019	Wheel Setting Bracket		2
85	W019	Spring Washer	5/8"x40xt3	2
86	S016	Hex. Head Screw	3/8"x3/4"L	2
87	192022	Wheel Rod		2
88	P202	Cotter Pin	φ 3x25L	2
89	181129	Wheel		2
90	N007	Hex. Nut	5/16"	6
91	W015	Spring Washer	5/16"x12xt2	12
92	S022	Hex. Head Screw	5/16"x3/4"L	6
93	192039	Knob W/Shaft		1
94	N005	Hex. Nut	3/8"	4
95	W014	Spring Washer	3/8"x23/t2	8

96	S013	Hex. Head Screw	3/8"X1-1/4"1	4
97	181256	Coolant Tank		1
98		Pump		1
99	W004	Spring Washer	1/4"x19xt1.5	4
100	S701	Cross Round Head Screw	1/4"x1/2"L	4
101	181854	Hose	OD16mmxID13mmx260m	1
102	181852	Coupler	3/8"PT	1
105	S708	Cross Round Head Screw	3/16x3/8"L	2
109	181401	Electrical Box		1
110	S708	Cross Round Head Screw	3/16x3/8"L	2
111	ET2107	Wire Nipple	1/2"	2
112	181402	Cover		1
190	101073	3 Way Valve		1
191	1341089	Hose Fitting	1/4PTx1/4"	2
192	192056	Hose	OD8xID6x1100L	1
193	S475	Hex. Socket Head Screw	1/4x1-1/4"L	2
194	192053	Valve	1/4"PTx5/16"	1
195	192058	Hose	OD12xID8x14000L	1
196	192057	Hose	OD8xID6x400L	1
197	101079	Hose Bib		2
200	192001	Body Frame		1
201	W204	Spring Washer	3/8"	4
202	S013	Hex. Head Screw	3/8"x1-1/4"L	4
203	192041	Supper Plate		1
204	W005	Spring Washer	1/4"x16xt1.5	2
205	S201	Cross Round Head Screw	1/4"x1/2"L	2
206	S608	Hex. Socket Headless Screw	5/16"x3/4"L	1
208	S708	Cross Round Head Screw(For CE Only)	3/16"x3/8"L	2

209	W007	Spring Washer(For CE Only)	3/16"x12xt0.8	2
210	192023A	Switch Cut Off Tip		1
211	W005	Spring Washer	1/4"x16x1.5	1
212	S201	Cross Round Head Screw	1/4"x1/2"L	1
213	1965052	Knob		1
214	S414	Hex. Socket Head Screw	5/16"x1"L	2
215	W008	Spring Washer	3/8"x25xt2	1
216	192038A	Blade Tension Bar		1
217	P003	Pin	φ 3x20L	1
218	192037A	Handle Body		1
218	192037B	Handle Body	<b>For Special Request</b>	1
219	3027-1	Knob		3
220	193050	Blade Wheel Shaft		1
221	P005	Pin	φ 4x22L	1
222	193052	Sliding Plate Draw Block		1
223	192052	Blade Tension Sliding Block		1
224	181210	Sliding Plate		2
225	192026	Spring		1
226	S608	Hex. Socket Headless Screw	5/16"x3/4"L	1
227	W205	Spring Washer	5/16"	4
228	S020	Hex. Head Screw	5/16"x1"L	4
229	W015	Spring Washer	5/16"x12xt2	2
230	S019	Hex. Head Screw	5/16"1-1/2"L	2
231	193051	Bushing		1
232	HCR06	C-Retainer Ring	R52	1
233	CA6205	Ball Bearing Ring(6202LLB)	6205	2
235	192016A	Idler Wheel		1
238	W017	Spring Washer	5/16"x18xt1.5	1

239	S022	Hex. Head Screw	5/16"x3/4"L	1
240	192050A	Blade	27x0.9x2655x5-8T	1
241	192014	Gear Box protector(For CE Only)		1
242	W005	Spring Washer( <b>For CE Only</b> )	1/4"x16xt1.5	2
243	S704	Cross Round Head Screw( <b>For CE Only</b> )	1/4"x3/8"L	2
244	181216-1AS	Gear Box Assembly		1
262	181226B	Spindle Pulley		1
263	S604	Hex. Socket Headless Screw	1/4"x3/8"L	2
264	192017A	Drive Wheel		1
265	S604	Hex. Socket Headless Screw	1/4"x3/8"L	2
266	181991	Emergency Switch Bracket(For CE Only)		1
267	S449	Hex. Socket Head Screw( <b>For CE Only</b> )	M6x15L	2
268	S708	Cross Round Head Screw( <b>For CE Only</b> )	3/16"x3/8"L	4
269	192034	Motor Mount Bracket		1
270	W016	Spring Washer	5/16"x23xt2	4
271	S022	Hex. Head Screw	5/16"x3/4"L	4
272	S022	Hex. Head Screw	5/16"x3/4"L	2
273	W018	Spring Washer	5/16"x23xt3	2
274	181234A	Motor Mount Plate		1
275	N007	Hex. Nut	5/16"	2
276	S021	Hex. Head Screw	5/16"x2"L	2
277	S503	Carriage Screw	5/16"x1"L	4
278		Motor		1
279	W016	Spring Washer	5/16"x23xt2	4
280	N007	Hex. Nut	5/16"	4
281	181235B	Motor Pulley		1
282	S604	Hex. Socket Headless Screw	1/4"x3/8"L	1
283	K008	Key	5x5x30L	1



284	181237I	Motor Pulley Cover		1
285	W202	Spring Washer	1/4"	2
286	S006	Hex. Head Screw	1/4"x1/2"L	2
288	3058	Plum Screw		1
289	192004S	Adjustable Bracket Assembly		1
290	W008	Spring Washer	3/8"x25xt2	3
291	S013	Hex. Head Screw	3/8"x1-1/4"L	1
295	W208	Spring Washer	3/8"	4
296	N006	Hex. Nut	3/8"UNF	4
301	W017	Spring Washer	5/16"x18xt1.5	1
302	W205	Spring Washer	5/16"	1
303	S416	Hex. Socket Head Screw	5/16"x1-1/4"L	1
308	192027S	Brush Assembly		1
317	192005S	Adjustable Bracket Assembly(Front		1
318	W008	Spring Washer	3/8"x25xt2	1
319	3066-3	Blade Adjustable Knob		1
320	181231A	Blade Cover (Front)		1
321	S711	Cross Round Head Screw	5/32"x1/4"L	2
326	181874	Belt	3Vx270	1
327	192002B	Blade Back Cover		1
329	W005	Spring Washer	1/4"x16xt1.5	4
330	S701	Cross Round Head Screw	1/4"x1/2"L	4
331	W005	Spring Washer	1/4"x16xt1.5	2
332	181202	Knob		2
337	N016	Nut	1/2"	2
338	W002	Spring Washer	1/2"x28xt2	2
339	192049	Bushing		1
340	181306	Bracket		1

340	181306A	Bracket	For Special Request	1
341	S720	Cross Round Head Screw	M4x5L	4
342	181305	Switch base		1
342	181305A	Switch base	For Special Request	1
343	W023	Spring Washer	M5	4
344	S721	Cross Round Head Screw	M5x10L	2
364	3027-1	Knob		1
365	193057	Knob		1
366	S601	Hex. Socket Headless Screw	1/4"x1/2"L	1
367	193055	Pressure Lump		1
368	HW007	Spring Washer	M12xt2	1
369	S013	Hex. Head Screw	3/8"x1-1/4"L	2
370	W013	Spring Washer	3/8"x20xt2	2
371	HP018	Pin	φ 5x20L	1
372	193056	Pressure Shaft		1
373	193059	Knob W/Shaft		1
374	290086	Plastic Round Knob		1
375	CA51101	Bearing		1
376	193063	Washer		1
377	193058	Spring		1

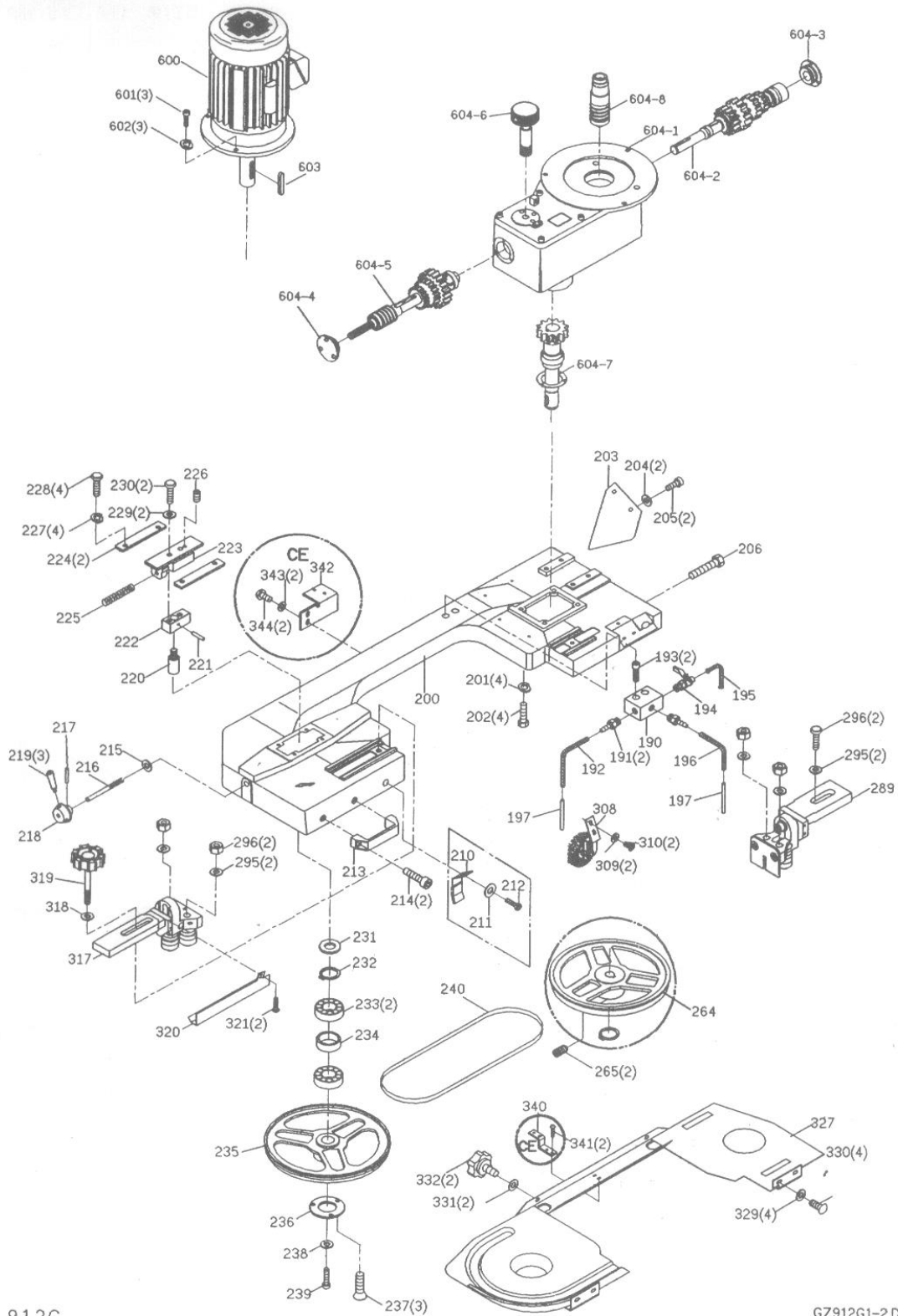

912G

GZ912G1-2.DWG  
90.02.23

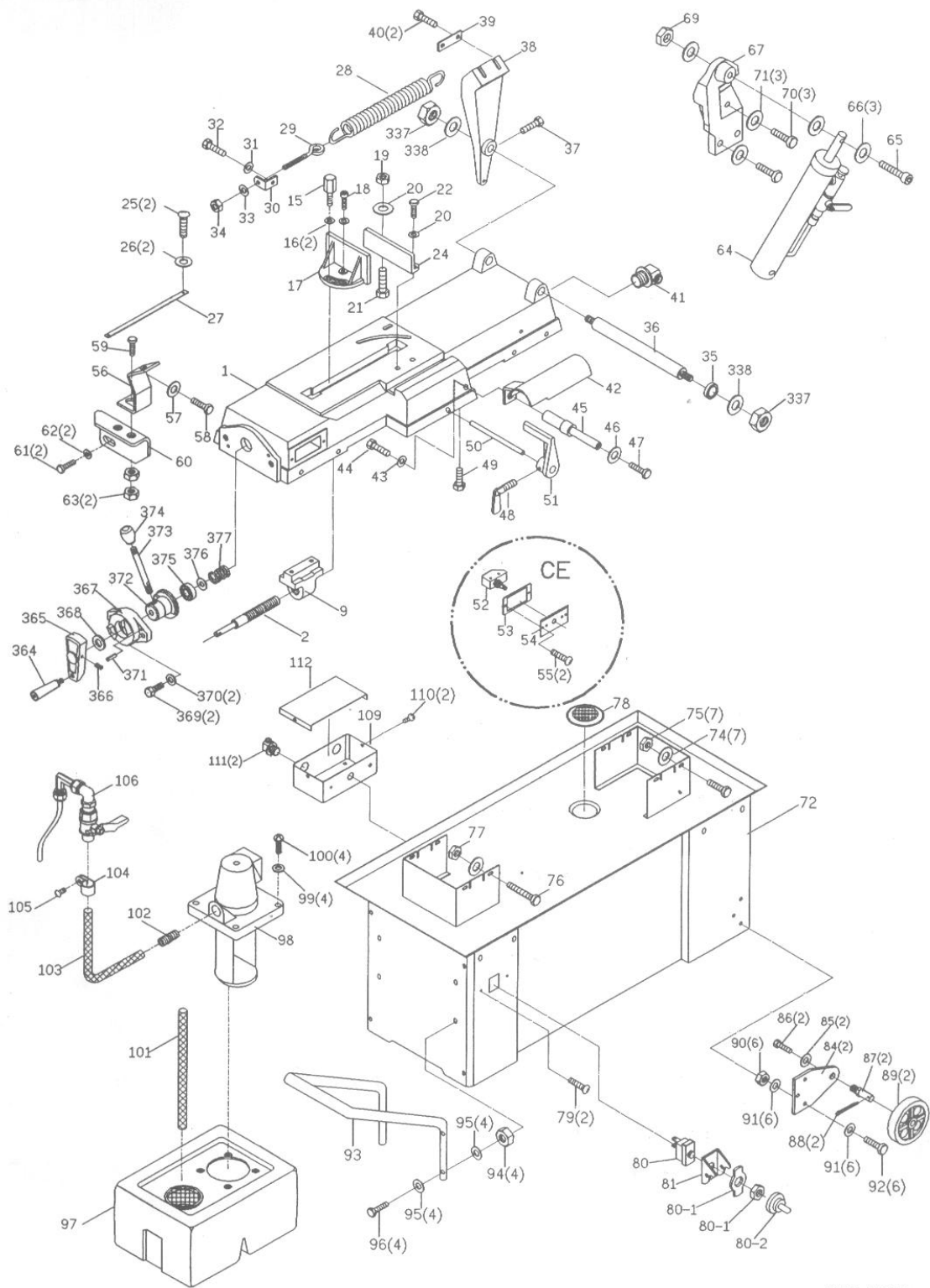

912 G

912B-1DWG  
90.01.04

## MODEL NO. 912G

### PART LIST

CODE	PART NO.	DESCRIPTION	SPECIFICATION	Q'TY
1	192012A	Swivel Base		1
2	192009A	Acme Screw		1
9	1811388B	Acme Nut		1
15	181266	Fixed Bolt		1
16	W008	Spring Washer	3/8"x25xt2	2
17	192015	Vise Jaw Bracket (Front)		1
18	S410	Hex. Socket Head Screw	3/8"x1-1/2"L	1
19	N001	Hex. Nut	1/2"	1
20	W002	Spring Washer	1/2"x28xt2	2
21	S501	Carriage Screw	1/2"x2"L	1
22	S003	Hex. Head Screw	1/2"x2"L	1
24	192008	Vise Jaw Bracket (Rear)		1
25	S708	Cross Round Head Screw	3/16"x3/8"L	2
26	W007	Spring Washer	3/16"x12xt0.8	2
27	192044	Scale		1
28	181117-1	Spring		1
29	181118	Spring Adjusting Screw		1
30	192040	Spring Handle Bracket		1
31	W016	Spring Washer	5/16"x23xt2	1
32	S022	Hex. Head Screw	5.16"x3/4"L	1
33	W014	Spring Washer	3/8"x23xt2	1
34	N005	Hex. Nut	3/8"	1
35	192051	Bushing		1
36	192042A	Support Rod		1

37	S022	Hex. Head Screw	5/16"x3/4"L	1
38	192003	Pivot Bracket		1
39	181270	Washer		1
40	S012	Hex. Head Screw	3/8"x1-1/2"L	2
41	ET2108	Wire Nipple	5/8"	1
42	192033	Cylinder Protector		1
43	W018	Spring Washer	5/16"x23xt3	2
44	S022	Hex. Head Screw	5/16"x3/4"L	2
45	181301-2	Cylinder Lower Support		1
46	W016	Spring Washer	5/16"x19xt1.5	1
47	S018	Hex. Head Screw	5/16"x1/2"L	1
48	191224	Thumb Screw		1
49	S022	Hex. Head Screw	5/16"x3/4"L	1
50	3021	Stock Stop Rod		1
51	181125	Distance Set Bracket		1
52	ET1624	Limit Switch		1
53	181431	Gear Box Gasket		1
54	181420	Cover		1
55	S708	Cross Round Head Screw	3/16"x3/8"L	2
56	192011	Fixed Plate		1
57	W005	Spring Washer	1/4"x16xt1.5	1
58	S019	Hex. Head Screw	5/16"x1-1/2"L	1
59	S014	Hex. Head Screw	3/8"x3/4"L	1
60	181112A	Support Plate		1
61	S022	Hex. Head Screw	5/16"x3/4"L	2
62	W017	Spring Washer	5/16"x18xt1.5	2
63	N005	Hex. Nut	3/8"	2
64	181304-2	Cylinder Complete Set	RF-712N	1

65	S412	Hex. Socket Head Screw	3/8"x2-1/4"L	1
66	W013	Spring Washer	3/8"x20xt2	3
67	181302-2	Cylinder Upper Support		1
69	N005	Hex. Nut	3/8"	1
70	S017	Hex. Head Screw	5/16"x1"L	3
72	192045S	Stand Complete Assembly		1
73	S017	Hex. Head Screw	5/16"x1"L	7
74	W017	Spring Washer	5/16"x18xt1.5	8
75	N007	Hex. Nut	5/16"	7
76	S013	Hex. Head Screw	3/8"x1-1/4"L	1
77	N005	Hex. Nut	3/8"	1
78	191106A	Filter		1
79	S708	Cross Round Head Screw	3/16"x3/8"L	2
80	ET1401	Toggle Switch		1
81	3131	Switch Cover		1
82	181932	Toggle Switch Cover		1
84	192019	Wheel Setting Bracket		2
85	W019	Spring Washer	5/8"x40xt3	2
86	S016	Hex. Head Screw	3/8"x3/4"L	2
87	192022	Wheel Rod		2
88	P202	Cotter Pin	φ 3x25L	2
89	181129	Wheel		2
90	N007	Hex. Nut	5/16"	6
91	W015	Spring Washer	5/16"x12xt2	12
92	S022	Hex. Head Screw	5/16"x3/4"L	6
93	192039	Knob W/Shaft		1
94	N005	Hex. Nut	3/8"	4
95	W014	Spring Washer	3/8"x23/t2	8

96	S013	Hex. Head Screw	3/8"X1-1/4"1	4
97	181256	Coolant Tank		1
98		Pump		1
99	W004	Spring Washer	1/4"x19xt1.5	4
100	S701	Cross Round Head Screw	1/4"x1/2"L	4
101	181854	Hose	OD16mmxID13mmx260m	1
102	181852	Coupler	3/8"PT	1
105	S708	Cross Round Head Screw	3/16x3/8"L	2
109	181401	Electrical Box		1
110	S708	Cross Round Head Screw	3/16x3/8"L	2
111	ET2107	Wire Nipple	1/2"	2
112	181402	Cover		1
190	101073	3 Way Valve		1
191	1341089	Hose Fitting	1/4PTx1/4"	2
192	192056	Hose	OD8xID6x1100L	1
193	S475	Hex. Socket Head Screw	1/4x1-1/4"L	2
194	192053	Valve	1/4"PTx5/16"	1
195	192058	Hose	OD12xID8x14000L	1
196	192057	Hose	OD8xID6x400L	1
197	101079	Hose Bib		2
200	192001	Body Frame		1
201	W204	Spring Washer	3/8"	4
202	S013	Hex. Head Screw	3/8"x1-1/4"L	4
203	192041	Supper Plate		1
204	W005	Spring Washer	1/4"x16xt1.5	2
205	S201	Cross Round Head Screw	1/4"x1/2"L	2
206	S608	Hex. Socket Headless Screw	5/16"x3/4"L	1
208	S708	Cross Round Head Screw(For CE Only)	3/16"x3/8"L	2



209	W007	Spring Washer(For CE Only)	3/16"x12xt0.8	2
210	192023A	Switch Cut Off Tip		1
211	W005	Spring Washer	1/4"x16x1.5	1
212	S201	Cross Round Head Screw	1/4"x1/2"L	1
213	1965052	Knob		1
214	S414	Hex. Socket Head Screw	5/16"x1"L	2
215	W008	Spring Washer	3/8"x25xt2	1
216	192038A	Blade Tension Bar		1
217	P003	Pin	φ 3x20L	1
218	192037A	Handle Body		1
218	192037B	Handle Body	<b>For Special Request</b>	1
219	3027-1	Knob		3
220	193050	Blade Wheel Shaft		1
221	P005	Pin	φ 4x22L	1
222	193052	Sliding Plate Draw Block		1
223	192052	Blade Tension Sliding Block		1
224	181210	Sliding Plate		2
225	192026	Spring		1
226	S608	Hex. Socket Headless Screw	5/16"x3/4"L	1
227	W205	Spring Washer	5/16"	4
228	S020	Hex. Head Screw(For CE Only)	5/16"x1"L	4
229	W015	Spring Washer	5/16"x12xt2	2
230	S019	Hex. Head Screw	5/16"1-1/2"L	2
231	193051	Bushing		1
232	HCR06	C-Retainer Ring	R52	1
233	CA6205	Ball Bearing Ring(6202LLB)	6205	2
235	192016A	Idler Wheel		1
238	W017	Spring Washer	5/16"x18xt1.5	1

239	S022	Hex. Head Screw	5/16"x3/4"L	1
240	192050A	Blade	27x0.9x2655x5-8T	1
264	192017A	Drive Wheel		1
265	S604	Hex. Socket Headless Screw	1/4"x3/8"L	2
266	181991	Emergency Switch Bracket	<b>For CE Only</b>	1
266	181991A	Emergency Switch Bracket	For Special Request	1
267	S449	Hex. Socket Head Screw(For CE Only)	M6x15L	2
268	S708	Cross Round Head Screw(For CE Only)	3/16"x3/8"L	4
289	192004S	Adjustable Bracket Assembly		1
290	W008	Spring Washer	3/8"x25xt2	3
291	S013	Hex. Head Screw	3/8"x1-1/4"L	1
295	W208	Spring Washer	3/8"	4
296	N006	Hex. Nut	3/8"UNF	4
301	W017	Spring Washer	5/16"x18xt1.5	1
302	W205	Spring Washer	5/16"	1
303	S416	Hex. Socket Head Screw	5/16"x1-1/4"L	1
308	192027S	Brush Assembly		1
317	192005S	Adjustable Bracket Assembly(Front		1
318	W008	Spring Washer	3/8"x25xt2	1
319	3066-3	Blade Adjustable Knob		1
320	181231A	Blade Cover (Front)		1
321	S711	Cross Round Head Screw	5/32"x1/4"L	2
327	192002B	Blade Back Cover		1
329	W005	Spring Washer	1/4"x16xt1.5	4
330	S701	Cross Round Head Screw	1/4"x1/2"L	4
331	W005	Spring Washer	1/4"x16xt1.5	2
332	181202	Knob		2
337	N016	Nut	1/2"	2

338	W002	Spring Washer	1/2"x28xt2	2
339	192049	Bushing		1
340	181306	Bracket		1
340	181306A	Bracket	For Special Request	1
341	S720	Cross Round Head Screw	M4x5L	4
342	181305	Switch base		1
342	181305A	Switch base	For Special Request	1
343	W023	Spring Washer	M5	4
344	S721	Cross Round Head Screw	M5x10L	2
364	3027-1	Knob		1
365	193057	Knob		1
366	S601	Hex. Socket Headless Screw	1/4"x1/2"L	1
367	193055	Pressure Lump		1
368	HW007	Spring Washer	M12xt2	1
369	S013	Hex. Head Screw	3/8"x1-1/4"L	2
370	W013	Spring Washer	3/8"x20xt2	2
371	HP018	Pin	φ 5x20L	1
372	193056	Pressure Shaft		1
373	193059	Knob W/Shaft		1
374	290086	Plastic Round Knob		1
375	CA51101	Bearing		1
376	193063	Washer		1
377	193058	Spring		1
600		Motor	<b>Vertical Style</b>	1
601	S414	Hex. Socket Head Screw	5/16"x1"	3
602	W205	Spring Washer	5/16"	3
603	K008	Key	5x5x30L	1
604-1	183002S	<b>Gear Box</b>		1

604-2	183006S	<b>Gear Shaft Assembly</b>	1
604-3	183021S	<b>Cover</b>	1
604-4	183022S	<b>Cover</b>	1
604-5	183016S	Variable Worm Shaft Assembly	11
604-6	183017AS	Variable Gear Shaft Assembly	1
604-7	183018S	Output Shaft Assembly	1
604-8	183004CS	<b>Worm Shaft Assembly</b>	1
	183001S	Gear Box Assembly	1

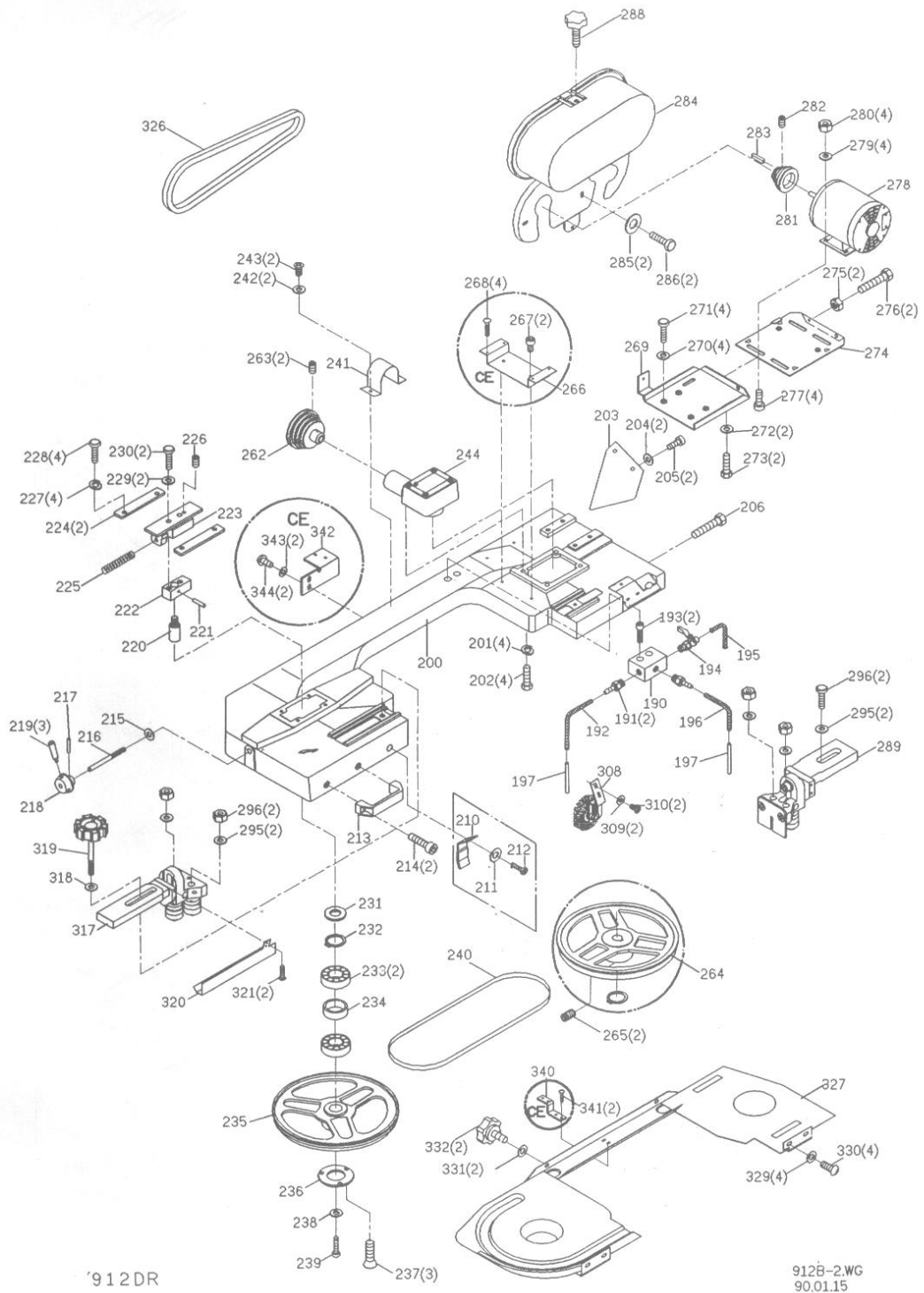

'912DR

912B-2.WG  
90.01.15

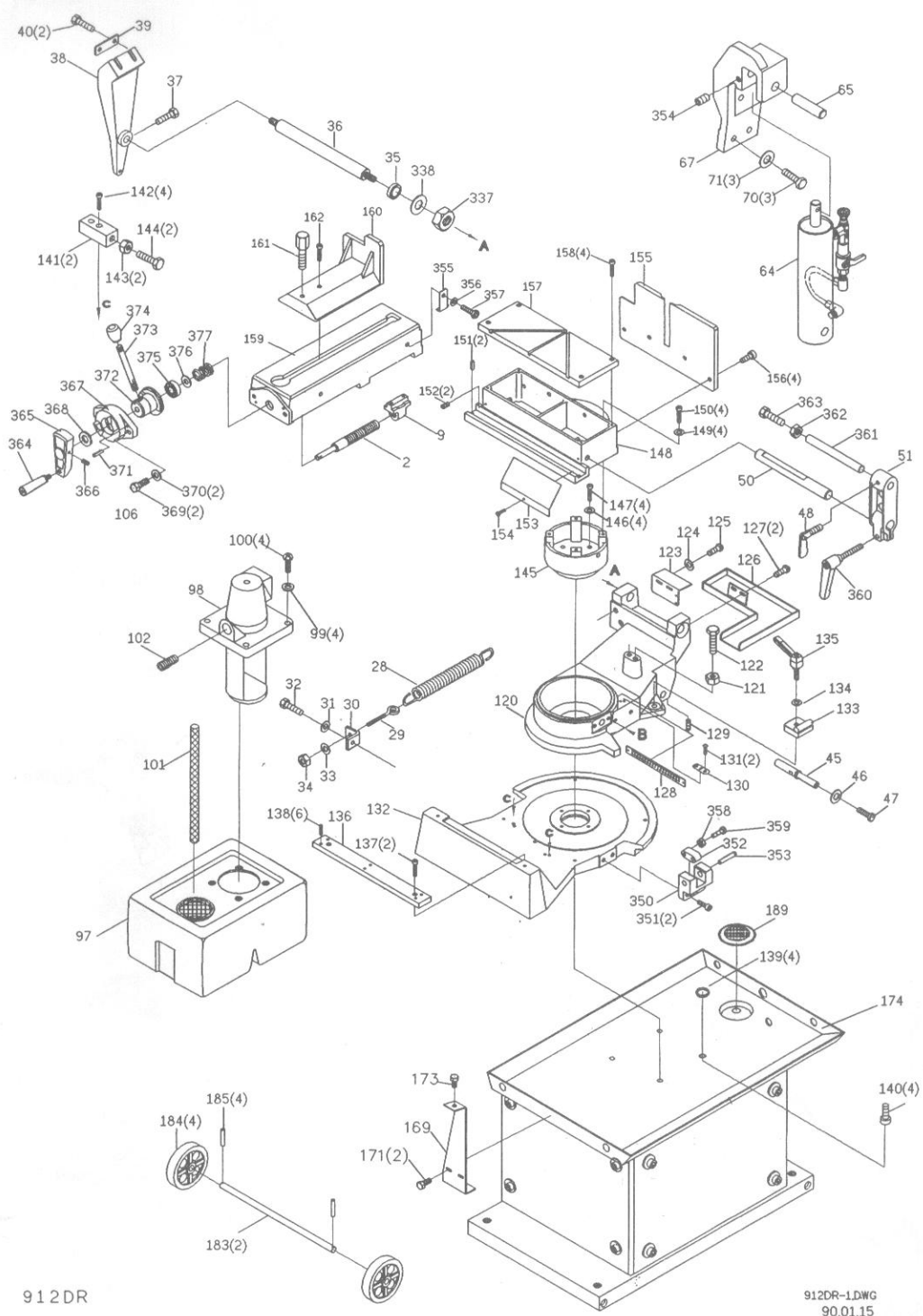

912DR

912DR-1DWG  
90.01.15

## MODEL NO. 912DR

### PART LIST

CODE	PART NO.	DESCRIPTION	SPECIFICATION	Q'TY
2	182037B	Acme Screw		1
9	1811388B	Acme Nut		1
28	181117-1	Spring		1
29	182049	Spring Adjusting Screw		1
30	193061	Spring Handle Bracket		1
31	W016	Spring Washer	5/16"x23xt2	1
32	S022	Hex. Head Screw	5.16"x3/4"L	1
33	W014	Spring Washer	3/8"x23xt2	1
34	N005	Hex. Nut	3/8"	1
35	193062	Bushing		1
36	192042A	Support Rod		1
37	S022	Hex. Head Screw	5/16"x3/4"L	1
38	192003	Pivot Bracket		1
39	181270	Washer		1
40	S012	Hex. Head Screw	3/8"x1-1/2"L	2
45	193036	Cylinder Lower Support		1
46	W016	Spring Washer	5/16"x19xt1.5	1
47	S018	Hex. Head Screw	5/16"x1/2"L	1
48	191224	Thumb Screw		1
50	3021A	Stock Stop Rod	For Special Request	1
50	196230	Distance Set Rod		
51	103039A	Stop Block Support		1
64	193048	Cylinder Complete Set		1
65	193037	Support Shaft		1

66	W013	Spring Washer	3/8"x20xt2	3
67	193038	Cylinder Upper Support		1
69	N005	Hex. Nut	3/8"	1
70	S017	Hex. Head Screw	5/16"x1"L	3
71	W017	Spring Washer	5/16"x18xt1.5	3
97	181256	Coolant Tank		1
98		Pump		1
99	W004	Spring Washer	1/4"x19xt1.5	4
100	S701	Cross Round Head Screw	1/4"x1/2"L	4
101	181854	Hose	OD16mmxID13mmx260m	1
102	181852	Coupler	3/8"PT	1
105	S708	Cross Round Head Screw	3/16x3/8"L	2
120	193009	Swivel Arm		1
121	N001	Hex. Nut	1/2"	1
122	193032	Bolt		1
123	193046	Power Cutting Bracket		1
124	W007	Spring Washer	M5	2
125	S721	Cross Round Head Screw	M5x10L	2
126	182061	Splash Board		1
127	S732	Cross Round Head Screw	5/16"x15L	2
128	193034	Degree-Meter		1
129	S607	Hex. Socket Headless Screw	5/16"x1/2"L	1
130	1976015	Meter Indicator		1
131	HH001	Rivet	φ 2x5L	2
132	193017	Swivel Base		1
133	193039	Swivel Arm Block		1
134	W008	Flat Washer	3/8"	1
135	191210A	Knob		1



136	193016	Adjustable Support		1
137	S404	Hex. Socket Head Screw	1/4"x3/4"L	2
138	S626	Hex. Socket Headless Screw	1/8"x1/2"L	6
139	HO028	O-Retainer Ring	φ 2x φ 10	4
140	S458	Hex. Socket Head Screw	M8x15L	4
141	193025	Swivel Locating Block		2
142	S007	Hex. Socket Head Screw	1/4"x1-1/4"L	4
143	N005	Hex. Nut	3/8"	2
144	S015	Hexagon Head Screw	3/8"x2"L	1
145	193010	Fixed Shaft		1
146	W204	Spring Washer	3/8"	4
147	S410	Hex. Socket Head Screw	3/8"x1-1/2"L	4
148	193012A	Vise Base		1
149	W008	Spring Washer	3/8"x25xt2	4
150	S410	Hex. Socket Head Screw	3/8"x1-1/2"L	4
151	P008	Pin	φ 5x16L	2
152	S607	Hex. Socket Headless Screw	5/16"x1/2"L	2
153	193022	Water Leading Board		1
154	S452	Hex. Socket Head Screw	M6x25L	1
155	193018	Vise Jaw Bracket (Rear)		1
156	S013	Hex. Socket Head Screw	3/8"x1-1/4"L	4
157	193014	Vise Base Plate		1
158	S404	Hex. Socket Head Screw	1/4:x3/4"L	4
159	193011A	Vise Jaw Base		1
160	193013	Vise Jaw Bracket(Front)		1
162	S015	Hex. Socket Head Screw	3/8"x2"L	2
169	193033A	Fixed Plate		1
171	S006	Hex. Head Screw	1/4"x1/2"L	1

173	S022	Hex. Head Screw	5/16"x3/4"L	1
174	193008S	Stand Complete Assembly	<b>For Standard Stand</b>	1
177	182030-2S	Stand Complete Assembly	<b>For Higher Stand</b>	1
178	193008ST	Stand Complete Assembly		1
183	181128	Wheel Rod	<b>For Standard Stand</b>	2
184	181129	Wheel	<b>For Standard Stand</b>	4
185	P202	Cotter Pin(For Standard Stand)	ϕ 3x25L	4
187	N001	Hex. Nut(For Higher Stand Only)	1/2"	4
188	182063	Coaster of Stand (For Higher Stand Only)	1/2"	4
189	191106A	Filter		1
190	101073	3 Way Valve		1
191	1341089	Hose Fitting	1/4PTx1/4"	2
192	192056	Hose	OD8xID6x1100L	1
193	S475	Hex. Socket Head Screw	1/4x1-1/4"L	2
194	192053	Valve	1/4"PTx5/16"	1
195	192058	Hose	OD12xID8x14000L	1
196	192057	Hose	OD8xID6x400L	1
197	101079	Hose Bib		2
200	192001	Body Frame		1
201	W204	Spring Washer	3/8"	4
202	S013	Hex. Head Screw	3/8"x1-1/4"L	4
203	192041	Supper Plate		1
204	W005	Spring Washer	1/4"x16xt1.5	2
205	S201	Cross Round Head Screw	1/4"x1/2"L	2
206	S608	Hex. Socket Headless Screw	5/16"x3/4"L	1
208	S708	Cross Round Head Screw(For CE Only)	3/16"x3/8"L	2
209	W007	Spring Washer(For CE Only)	3/16"x12xt0.8	2
213	1965052	Knob		1

214	S414	Hex. Socket Head Screw	5/16"x1"L	2
215	W008	Spring Washer	3/8"x25xt2	1
216	192038A	Blade Tension Bar		1
217	P003	Pin	φ 3x20L	1
218	192037A	Handle Body		1
218	192037B	Handle Body	<b>For Special Request</b>	1
219	3027-1	Knob		3
220	193050	Blade Wheel Shaft		1
221	P005	Pin	φ 4x22L	1
222	193052	Sliding Plate Draw Block		1
223	192052	Blade Tension Sliding Block		1
224	181210	Sliding Plate		2
225	192026	Spring		1
226	S608	Hex. Socket Headless Screw	5/16"x3/4"L	1
227	W205	Spring Washer	5/16"	4
228	S020	Hex. Head Screw	5/16"x1"L	4
229	W015	Spring Washer	5/16"x12xt2	2
230	S019	Hex. Head Screw	5/16"1-1/2"L	2
231	193051	Bushing		1
232	HCR06	C-Retainer Ring	R52	1
233	CA6205	Ball Bearing (6202LLB)	6205	2
235	192016A	Idler Wheel		1
238	W017	Spring Washer	5/16"x18xt1.5	1
239	S022	Hex. Head Screw	5/16"3/4"L	1
240	192050A	Blade	27x0.9x2655x5-8T	1
241	192014	Gear Box protector(For CE Only)		1
242	W005	Spring Washer( <b>For CE Only</b> )	1/4"x16xt1.5	2
243	S704	Cross Round Head Screw( <b>For CE Only</b> )	1/4"3/8"L	2

244	181216-1AS	Gear Box Assembly		1
262	181226B	Spindle Pulley		1
263	S604	Hex. Socket Headless Screw	1/4"x3/8"L	2
264	192017A	Drive Wheel		1
265	S604	Hex. Socket Headless Screw	1/4"x3/8"L	2
266	181991	Emergency Switch Bracket(For CE Only)		1
266	181991A	Emergency Switch Bracket	<b>For Special Request</b>	1
267	S449	Hex. Socket Head Screw(For CE Only)	M6x15L	2
268	S708	Cross Round Head Screw(For CE Only)	3/16"x3/8"L	4
269	192034	Motor Mount Bracket		1
270	W016	Spring Washer	5/16"x23xt2	4
271	S022	Hex. Head Screw	5/16"x3/4"L	4
272	S022	Hex. Head Screw	5/16"x3/4"L	2
273	W018	Spring Washer	5/16"x23xt3	2
274	181234A	Motor Mount Plate		1
275	N007	Hex. Nut	5/16"	2
276	S021	Hex. Head Screw	5/16"x2"L	2
277	S503	Carriage Screw	5/16"x1"L	4
278		Motor		1
279	W016	Spring Washer	5/16"x23xt2	4
280	N007	Hex. Nut	5/16"	4
281	181235B	Motor Pulley		1
282	S604	Hex. Socket Headless Screw	1/4"x3/8"L	1
283	K008	Key	5x5x30L	1
284	181237I	Motor Pulley Cover		1
285	W202	Spring Washer	1/4"	2
286	S006	Hex. Head Screw	1/4"x1/2"L	2
288	3058	Plum Screw		1

289	192004S	Adjustable Bracket Assembly(Rear)		1
290	W008	Spring Washer	3/8"x25xt2	3
291	S013	Hex. Head Screw	3/8"x1-1/4"L	1
295	W208	Spring Washer	3/8"	2
295	W208	Spring Washer	3/8"	2
296	N006	Hex. Nut	3/8"UNF	2
296	N006	Hex. Nut	3/8"UNF	2
301	W017	Spring Washer	5/16"x18xt1.5	1
302	W205	Spring Washer	5/16"	1
303	S416	Hex. Socket Head Screw	5/16"x1-1/4"L	1
308	192027S	Brush Assembly		1
317	192005S	Adjustable Bracket Assembly(Front		1
318	W008	Spring Washer	3/8"x25xt2	1
319	3066-3	Blade Adjustable Knob		1
320	181231A	Blade Cover (Front)		1
321	S711	Cross Round Head Screw	5/32"x1/4"L	2
326	181874	Belt	3Vx270	1
327	192002B	Blade Back Cover		1
329	W005	Spring Washer	1/4"x16xt1.5	4
330	S701	Cross Round Head Screw	1/4"x1/2"L	4
331	W005	Spring Washer	1/4"x16xt1.5	2
332	181202	Knob		2
337	N016	Nut	1/2"	2
338	W002	Spring Washer	1/2"x28xt2	2
339	192049	Bushing		1
340	181306	Bracket		1
340	181306A	Bracket	For Special Request	1
341	S720	Cross Round Head Screw	M4x5L	4

342	181305	Switch base		1
342	181305A	Switch base	For Special Request	1
343	W023	Spring Washer	M5	4
344	S721	Cross Round Head Screw	M5x10L	2
350	193029	Protractor Locating Bracket		1
351	S415	Hex. Socket Head Screw	5/16"x1/2"L	2
352	193030	Protractor Locating Bracket		1
353	103026	Bearing Pin		1
354	S601	Hex. Socket Headless Screw	1/4"x1/2"L	1
355	193047	Support Plate		1
356	W005	Spring Washer	1/4"x16xt1.5	1
357	S006	Hex. Head Screw	1/4"x1/2"L	1
358	N005	Hex. Nut	3/8"	1
359	S015	Hexagon Head Screw	3/8"x2"L	1
360	193053	Grip		1
361	103076	Distance Set Rod		1
362	HN006	Hex. Nut	M10	1
363	HS062	Hex. Head Screw	M10x40L	1
364	3027-1	Knob		1
365	193057	Knob		1
366	S601	Hex. Socket Headless Screw	1/4"x1/2"L	1
367	193055	Pressure Lump		1
368	HW007	Spring Washer	M12xt2	1
369	S013	Hex. Head Screw	3/8"x1-1/4"L	2
370	W013	Spring Washer	3/8"x20xt2	2
371	HP018	Pin	φ 5x20L	1
372	193056	Pressure Shaft		1
373	193059	Knob W/Shaft		1

374	290086	Plastic Round Knob	1
375	CA51101	Bearing	1
376	193063	Washer	1
377	193058	Spring	1

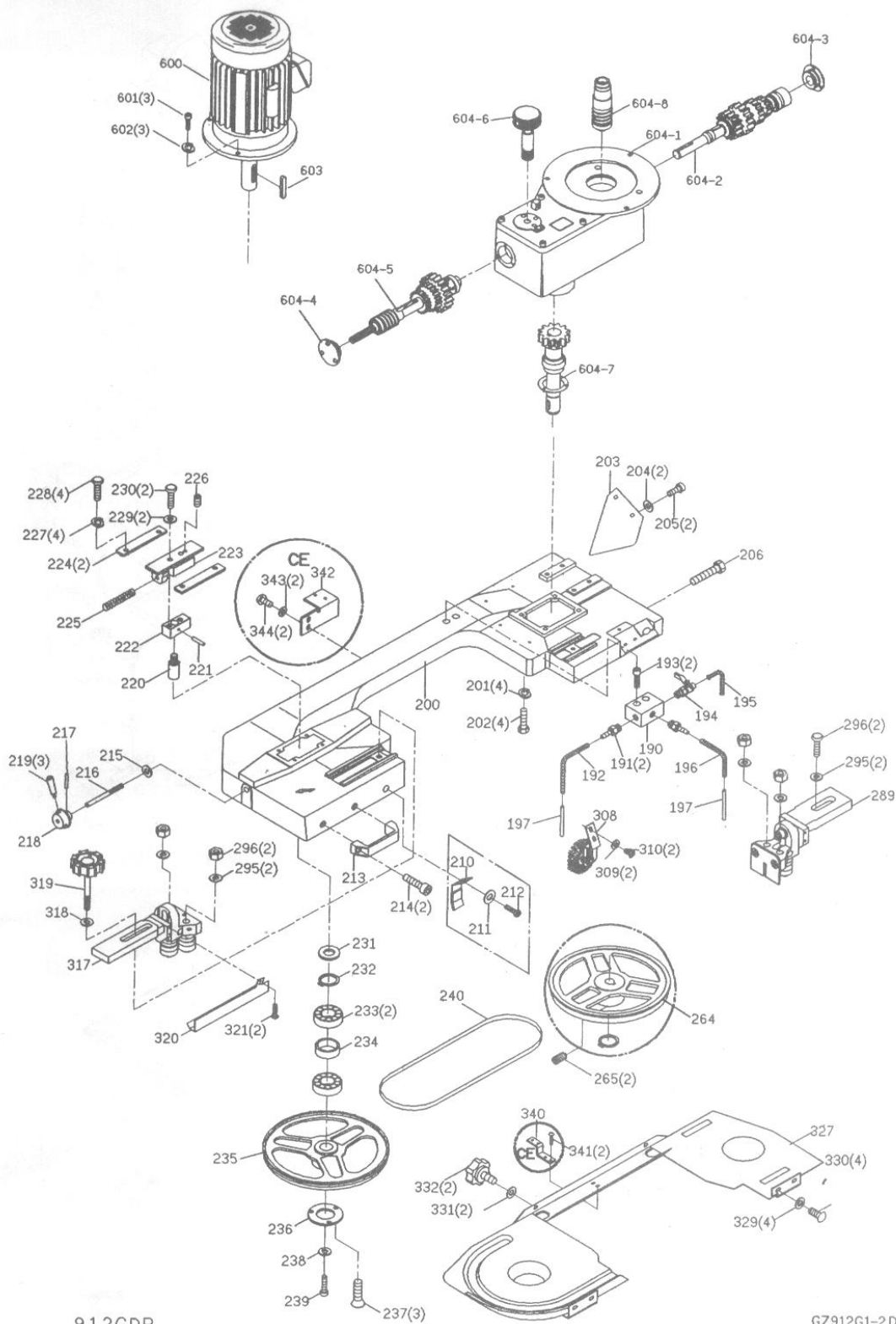

912GDR

GZ912G1-2.DWG  
90.02.23



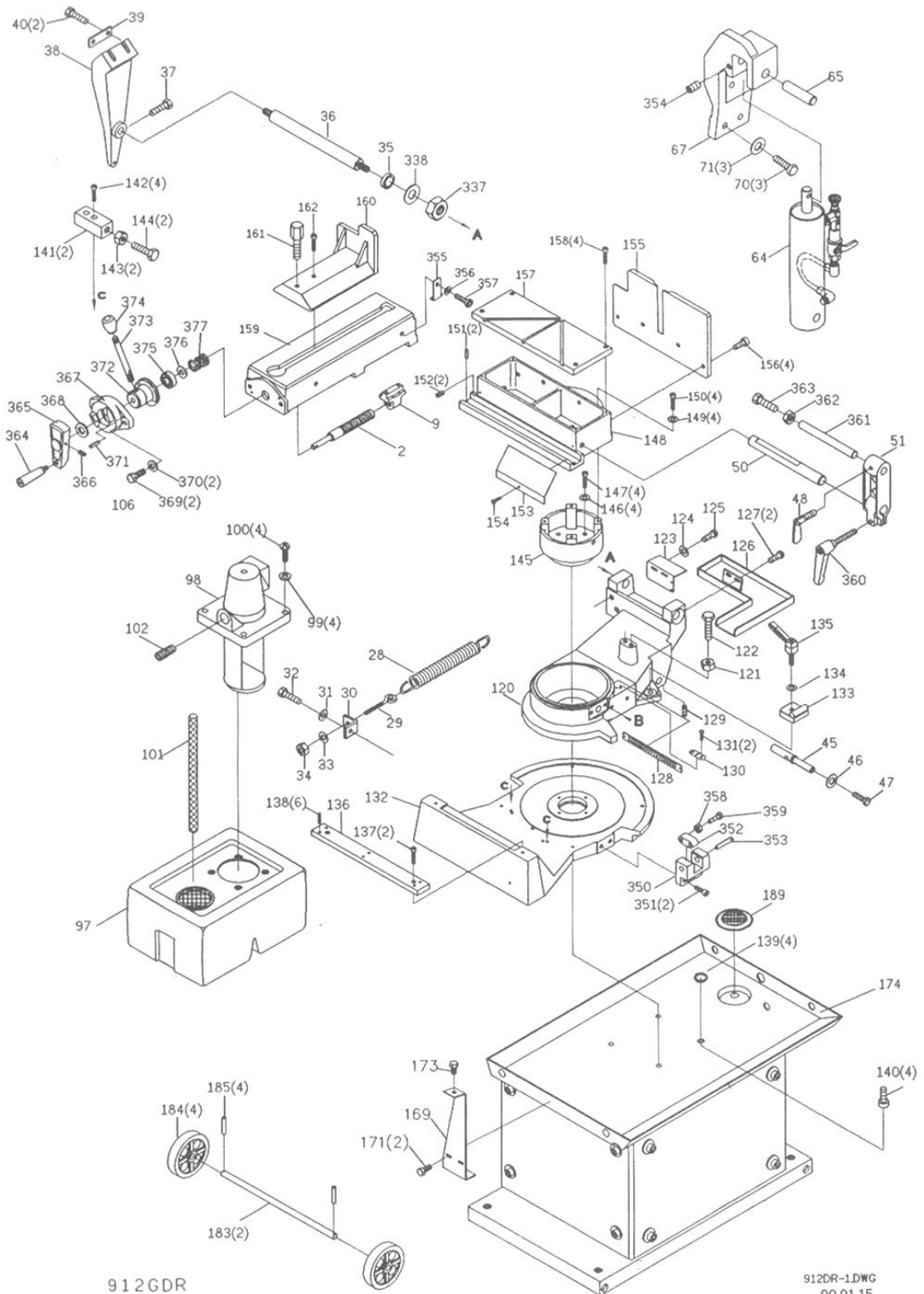

912GDR

912DR-1DWG  
90.01.15

## MODEL NO. 912GDR

### PART LIST

CODE	PART NO.	DESCRIPTION	SPECIFICATION	Q'TY
2	182037B	Acme Screw		1
9	1811388B	Acme Nut		1
28	181117-1	Spring		1
29	182049	Spring Adjusting Screw		1
30	193061	Spring Handle Bracket		1
31	W016	Spring Washer	5/16"x23xt2	1
32	S022	Hex. Head Screw	5.16"x3/4"L	1
33	W014	Spring Washer	3/8"x23xt2	1
34	N005	Hex. Nut	3/8"	1
35	193062	Bushing		1
36	192042A	Support Rod		1
37	S022	Hex. Head Screw	5/16"x3/4"L	1
38	192003	Pivot Bracket		1
39	181270	Washer		1
40	S012	Hex. Head Screw	3/8"x1-1/2"L	2
45	193036	Cylinder Lower Support		1
46	W016	Spring Washer	5/16"x19xt1.5	1
47	S018	Hex. Head Screw	5/16"x1/2"L	1
48	191224	Thumb Screw		1
50	3021A	Stock Stop Rod	<b>For Special Request</b>	1
50	196230	Distance Set Rod		
51	103039A	Stop Block Support		1
64	193048	Cylinder Complete Set		1
65	193037	Support Shaft		1

66	W013	Spring Washer	3/8"x20xt2	3
67	193038	Cylinder Upper Support		1
69	N005	Hex. Nut	3/8"	1
70	S017	Hex. Head Screw	5/16"x1"L	3
71	W017	Spring Washer	5/16"x18xt1.5	3
97	181256	Coolant Tank		1
98	H99049	Pump		1
99	W004	Spring Washer	1/4"x19xt1.5	4
100	S701	Cross Round Head Screw	1/4"x1/2"L	4
101	181854	Hose	OD16mmxID13mmx260m	1
102	181852	Coupler	3/8"PT	1
105	S708	Cross Round Head Screw	3/16x3/8"L	2
120	193009	Swivel Arm		1
121	N001	Hex. Nut	1/2"	1
122	193032	Bolt		1
123	193046	Power Cutting Bracket		1
124	W007	Spring Washer	M5	2
125	S721	Cross Round Head Screw	M5x10L	2
126	182061	Splash Board		1
127	S732	Cross Round Head Screw	5/16"x15L	2
128	193034	Degree-Meter		1
129	S607	Hex. Socket Headless Screw	5/16"x1/2"L	1
130	1976015	Meter Indicator		1
131	HH001	Rivet	φ 2x5L	2
132	193017	Swivel Base		1
133	193039	Swivel Arm Block		1
134	W008	Flat Washer	3/8"	1
135	191210A	Knob		1

136	193016	Adjustable Support		1
137	S404	Hex. Socket Head Screw	1/4"x3/4"L	2
138	S626	Hex. Socket Headless Screw	1/8"x1/2"L	6
139	HO028	O-Retainer Ring	φ 2x φ 10	4
140	S458	Hex. Socket Head Screw	M8x15L	4
141	193025	Swivel Locating Block		2
142	S007	Hex. Socket Head Screw	1/4"x1-1/4"L	4
143	N005	Hex. Nut	3/8"	2
144	S015	Hexagon Head Screw	3/8"x2"L	1
145	193010	Fixed Shaft		1
146	W204	Spring Washer	3/8"	4
147	S410	Hex. Socket Head Screw	3/8"x1-1/2"L	4
148	193012A	Vise Base		1
149	W008	Spring Washer	3/8"x25xt2	4
150	S410	Hex. Socket Head Screw	3/8"x1-1/2"L	4
151	P008	Pin	φ 5x16L	2
152	S607	Hex. Socket Headless Screw	5/16"x1/2"L	2
153	193022	Water Leading Board		1
154	S452	Hex. Socket Head Screw	M6x25L	1
155	193018	Vise Jaw Bracket (Rear)		1
156	S013	Hex. Socket Head Screw	3/8"x1-1/4"L	4
157	193014	Vise Base Plate		1
158	S404	Hex. Socket Head Screw	1/4:x3/4"L	4
159	193011A	Vise Jaw Base		1
160	193013	Vise Jaw Bracket(Front)		1
162	S015	Hex. Socket Head Screw	3/8"x2"L	2
169	193033A	Fixed Plate		1
171	S006	Hex. Head Screw	1/4"x1/2"L	1

173	S022	Hex. Head Screw	5/16"x3/4"L	1
174	193008S	Stand Complete Assembly	<b>For Standard Stand</b>	1
177	182030-2S	Stand Complete Assembly	<b>For Higher Stand</b>	1
178	193008ST	Stand Complete Assembly	<b>For Special Request</b>	1
183	181128	Wheel Rod	<b>For Standard Stand</b>	2
184	181129	Wheel	<b>For Standard Stand</b>	4
185	P202	Cotter Pin(For Standard Stand)	φ 3x25L	4
187	N001	Hex. Nut(For Higher Stand )	1/2"	4
188	182063	Coaster of Stand (For Higher Stan)	1/2"	4
189	191106A	Filter		1
190	101073	3 Way Valve		1
191	1341089	Hose Fitting	1/4PTx1/4"	2
192	192056	Hose	OD8xID6x1100L	1
193	S475	Hex. Socket Head Screw	1/4x1-1/4"L	2
194	192053	Valve	1/4"PTx5/16"	1
195	192058	Hose	OD12xID8x14000L	1
196	192057	Hose	OD8xID6x400L	1
197	101079	Hose Bib		2
200	192001	Body Frame		1
201	W204	Spring Washer	3/8"	4
202	S013	Hex. Head Screw	3/8"x1-1/4"L	4
203	192041	Supper Plate(Optional)		1
204	W005	Spring Washer	1/4"x16xt1.5	2
205	S201	Cross Round Head Screw	1/4"x1/2"L	2
206	S608	Hex. Socket Headless Screw	5/16"x3/4"L	1
208	S708	Cross Round Head Screw(For CE Only)	3/16"x3/8"L	2
209	W007	Spring Washer(For CE Only)	3/16"x12xt0.8	2
213	1965052	Knob		1

214	S414	Hex. Socket Head Screw	5/16"x1"L	1
215	W008	Spring Washer	3/8"x25xt2	1
216	192038A	Blade Tension Bar		1
217	P003	Pin	φ 3x20L	1
218	192037A	Handle Body		1
218	192037B	Handle Body	<b>For Special Request</b>	1
219	3027-1	Knob		3
220	193050	Blade Wheel Shaft		1
221	P005	Pin	φ 4x22L	1
222	193052	Sliding Plate Draw Block		1
223	192052	Blade Tension Sliding Block		1
224	181210	Sliding Plate		2
225	192026	Spring		1
226	S608	Hex. Socket Headless Screw	5/16"x3/4"L	1
227	W205	Spring Washer	5/16"	4
228	S020	Hex. Head Screw	5/16"x1"L	4
229	W015	Spring Washer	5/16"x12xt2	2
230	S019	Hex. Head Screw	5/16"1-1/2"L	2
231	193051	Bushing		1
232	HCR06	C-Retainer Ring	R52	1
233	CA6205	Ball Bearing (6202LLB)	6205	2
235	192016A	Idler Wheel		1
238	W017	Spring Washer	5/16"x18xt1.5	1
239	S022	Hex. Head Screw	5/16"3/4"L	1
240	192050A	Blade	27x0.9x2655x5-8T	1
264	192017A	Drive Wheel		1
265	S604	Hex. Socket Headless Screw	1/4"x3/8"L	2
266	181991	Emergency Switch Bracket	<b>For CE Only</b>	1

266	181991A	Emergency Switch Bracket	<b>For Special Request</b>	1
267	S449	Hex. Socket Head Screw(For CE Only)	M6x15L	2
268	S708	Cross Round Head Screw(For CE Only)	3/16"x3/8"L	4
289	192004S	Adjustable Bracket Assembly(Rear)		1
290	W008	Spring Washer	3/8"x25xt2	3
291	S013	Hex. Head Screw	3/8"x1-1/4"L	1
295	W208	Spring Washer	3/8"	2
295	W208	Spring Washer	3/8"	2
296	N006	Hex. Nut	3/8"UNF	2
296	N006	Hex. Nut	3/8"UNF	2
301	W017	Spring Washer	5/16"x18xt1.5	1
302	W205	Spring Washer	5/16"	1
303	S416	Hex. Socket Head Screw	5/16"x1-1/4"L	1
308	192027S	Brush Assembly		1
317	192005S	Adjustable Bracket Assembly(Front		1
318	W008	Spring Washer	3/8"x25xt2	1
319	3066-3	Blade Adjustable Knob		1
320	181231A	Blade Cover (Front)		1
321	S711	Cross Round Head Screw	5/32"x1/4"L	2
327	192002B	Blade Back Cover		1
329	W005	Spring Washer	1/4"x16xt1.5	4
330	S701	Cross Round Head Screw	1/4"x1/2"L	4
331	W005	Spring Washer	1/4"x16xt1.5	2
332	181202	Knob		2
337	N016	Nut	1/2"	2
338	W002	Spring Washer	1/2"x28xt2	2
339	192049	Bushing		1
340	181306	Bracket		1

340	181306A	Bracket	For Special Request	1
341	S720	Cross Round Head Screw	M4x5L	4
342	181305	Switch base		1
342	181305A	Switch base	For Special Request	1
343	W023	Spring Washer	M5	4
344	S721	Cross Round Head Screw	M5x10L	2
350	193029	Protractor Locating Bracket		1
351	S415	Hex. Socket Head Screw	5/16"x1/2"L	2
352	193030	Protractor Locating Bracket		1
353	103026	Bearing Pin		1
354	S601	Hex. Socket Headless Screw	1/4"x1/2"L	1
355	193047	Support Plate		1
356	W005	Spring Washer	1/4"x16xt1.5	1
357	S006	Hex. Head Screw	1/4"x1/2"L	1
358	N005	Hex. Nut	3/8"	1
359	S015	Hexagon Head Screw	3/8"x2"L	1
360	193053	Grip		1
361	103076	Distance Set Rod		1
362	HN006	Hex. Nut	M10	1
363	HS062	Hex. Head Screw	M10x40L	1
364	3027-1	Knob		1
365	193057	Knob		1
366	S601	Hex. Socket Headless Screw	1/4"x1/2"L	1
367	193055	Pressure Lump		1
368	HW007	Spring Washer	M12xt2	1
369	S013	Hex. Head Screw	3/8"x1-1/4"L	2
370	W013	Spring Washer	3/8"x20xt2	2
371	HP018	Pin	φ 5x20L	1



372	193056	Pressure Shaft		1
373	193059	Knob W/Shaft		1
374	290086	Plastic Round Knob		1
375	CA51101	Bearing		1
376	193063	Washer		1
377	193058	Spring		1
600		Motor	<b>Vertical Style</b>	1
601	S414	Hex. Socket Head Screw	5/16"x1"	3
602	W205	Spring Washer	5/16"	1
603	K008	Key	5x5x30L	1
604-1	183002S	<b>Gear Box</b>		1
604-2	183006S	<b>Gear Shaft Assembly</b>		1
604-3	183021S	<b>Cover</b>		1
604-4	183022S	<b>Cover</b>		1
604-5	183016S	Variable Worm Shaft Assembly		11
604-6	183017AS	Variable Gear Shaft Assembly		1
604-7	183018S	Output Shaft Assembly		1
604-8	183004CS	<b>Worm Shaft Assembly</b>		1
	183001S	Gear Box Assembly		1