

# Tube Notcher

**PN-1/2A**



**Operation manual**

## **Assembly:**

After unpacking the notcher it will need final assembly. The Bearing Block and V-Bracket assemblies shown in figure 2 and 3 have been pre-assembled at the factory. Refer to figures 1-3 for part identification. The completely assembled notcher is shown on the front cover.

1) Using two 3/8"x1" bolts and washers, attach the V-Bracket assembly onto the frame.

2) Using two 3/8"x1" bolts and washers, attach the Bearing Block assembly onto the frame.

3) Place the Tube Clamp Bracket onto the Tube Clamp and using two 3/8"x1 1/2" bolts only fasten it to the V-Bracket assembly.

4) Screw the T-Handle into the Tube Clamp as shown in figure 1.

5) Using one 3/8"x1" bolt and washer, attach the Swivel onto the Base as shown in figure 1. Next using one 3/8"x1" bolt and washer install this Base assembly onto the frame. Note: The Base and swivel are for operation of the notcher in the vertical position. Since this is NOT the recommended way to operate the notcher you may omit this step and leave the Base assembly off the notcher if desired. The advantages and operation of the notcher horizontally is explained later.

6) The notcher comes with a hole saw adapter and spacer. This adapter will generally need to be used for hole saws over 1" in diameter. To use, screw the adapter onto the shaft. Next place the spacer onto the adapter. Lastly, install the hole saw onto the adapter. The spacer must be installed between the adapter and the hole saw. Its purpose is to space the hole saw

away from the adapter's base so as to prevent the threads from being stripped off during operation. Note: Use only Bi-Metal hole saws for maximum blade life.

### **Mounting:**

Generally we do not recommend the notcher to be mounted vertically, such as in a drill press. The reason is simple, when you need to make an angled notch, 45 degrees for example, the tubing will be angled down towards the floor. Obviously, this will drastically restrict the length of tube you can notch without contacting the floor.

Mounting in a drill is also not recommended. The main problem is that every time you need to notch some tubing you must accurately install it on the drill press. This is not as easy as you would think. If the alignment of the drill press shaft and notcher shaft is not perfect, during operation the shaft's 1/2" tang will experience a bending force during rotation. Eventually, the tang may actually break off due to metal fatigue. If once installed in the drill press you decide to leave it there always, you have essentially tied up a piece of equipment that could be used for other operations. So in short, don't use a drill press.

So what do you do? First remove the Base assembly from the notcher if it has been installed. Position the notcher so that its face is pointing straight up and its shaft is toward you. Using a C-Clamp fasten it to your work surface making sure that the bolt heads on the rear of the notcher are over hanging the work surface's top. Now using the cheapest 1/2" drill money can buy, preferably one with a keyless chuck, attach the drill to the shaft's tang. Three flats have been milled into the shaft's tang to prevent drill slippage. You're done.

So what are the advantages of mounting the notcher

horizontally?

- 1) You haven't dedicated a drill press to notching.
- 2) You can easily notch long pieces of tubing at any angle the notcher allows because the tubing always remains parallel to the floor.
- 3) As you feed the hole saw into the tubing you have a better feel of what the hole saw is doing.

**Operation:**

Adjust the notcher to the angle desired. Place the tube into the notcher. As a general rule, try not to notch through the whole tube at one time. Place the tube into the notcher so that as the hole saw cuts through the tubing it barely misses the middle of the tube's end when cutting. This is shown in figure 4 . This allows the first half to break off before the hole saw cuts the second half. If you must cut through the entire tube you will probably bottom out the hole saw. This occurs when you notch angles. Simply retract the hole saw and using a pair of pliers bend back the cut piece so the saw may continue cutting. Don't worry, it's easier than it sounds. If the notcher is cutting slightly off center, you can loosen the V-Bracket bolts and adjust them to center the blade. Keep in mind that as you change blade sizes, the cutting forces change usually resulting in a very slight alignment error. However, once welded you will never notice it. Use a spray lubricant while cutting and feed the drill with a steady but unforced feed. Usually a notch can be made in 7-11 seconds.

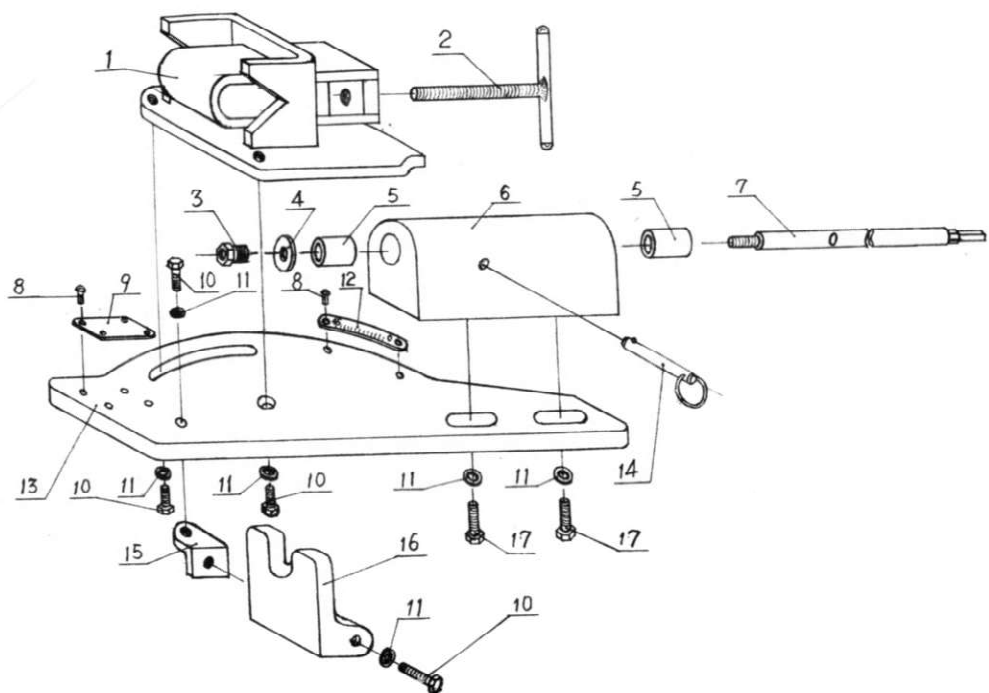

## Part list

No.	Description	Qty
1	Clamp Assembly	1
2	Handle /Clamp Screw	1
3	5/8" Hole Saw Adapter	1
4	5/8" Hole Saw Adapter Washer	1
5	Bushing	2
6	Spindle Support	1
7	Spindle	1
8	Rivet	2
9	Label	2
10	Bolt M8X20	4
11	Washer 8mm	6
12	Angle Indicator	1
13	Body	1
14	Retaining Pin	1
15	Adjustment Plate	1
16	Mounting Plate	1
17	Bolt M8 x 25	2