

KAKA Industrial®

Unpacking

The Hand Shear is shipped from the manufacturer in a carefully packed Carton box. Thoroughly inspect the product upon opening the package.

After unpacking the unit, carefully inspect for any damage that may have occurred during transit. Check for loose, missing, or damaged parts. Shipping damage claims must be filed with the carrier and are the responsibility of the user.

Specifications



Stock No.	172303
Model.....	HSG-8
Blade length.....	8" (203 mm)
Plate steel.....	0.24" (6 mm)
Flat steel.....	2.76"x0.24" (70x6 mm)
Round steel.....	0.51" (13 mm)
Packing size.....	20"x6"x18" (50x15x45 cm)
N.W/G.W.	42/44 lbs (19/20 kg)

Important:

Blades are coated with a protectant. To ensure proper fit and operation, remove coating. Coating is easily removed with mild solvents, such as mineral spirits, and a soft cloth. Avoid getting cleaning solution on paint or any of the rubber or plastic parts. Solvents may deteriorate these finishes. Use soap and water on paint, plastic or rubber components. After cleaning, cover all exposed surfaces with a light coating of oil.

▲ WARNING

Never use highly volatile solvents. Non-flammable solvents are recommended to avoid possible fire hazard.

SAVE THESE INSTRUCTIONS

Thank you for purchasing our HSG-8 Hand Shear. Before attempting to operate your new tool please read these instructions thoroughly. You will need these instructions for the safety warnings, precautions, assembly, operation, maintenance procedures, parts list and diagrams. Keep your invoice number with these instructions. Write the invoice number on the inside of front cover. Keep the instructions and invoice in a safe, dry place for future reference.

General Safety Information

▲ CAUTION

Always follow proper operating procedures as defined in this manual even if you are familiar with use of this or similar tools. Remember that being careless for even a fraction of a second can result in severe personal injury.

SAFETY RULES

1. Wear proper apparel. Do not wear loose clothing, gloves, neckties, rings, bracelets or other jewelry which may get caught in moving parts of machine.
2. Wear protective hair covering to contain long hair.
3. Wear safety shoes with non-slip soles.
4. Wear safety glasses complying with United States ANSI Z87.1.

Model HSG-8

Everyday glasses have only impact resistant lenses. They are NOT safety glasses.

5. Be alert and think clearly. Never operate tools when tired, intoxicated or when taking medications that cause drowsiness.

6. Keep work area clean. Cluttered work areas invite accidents.

7. Work area should be properly lit.

8. Keep visitors at a safe distance from work area.

9. Keep children out of workplace. Make workshop childproof. Use padlocks to prevent any unintentional use of tools.

10. Assemble only according to these instructions. Improper assembly can create hazards.

11. When tools are not in use, store them in a dry, secure place out of the reach of children. Inspect the tools prior to storage and before reuse.

12. Maintain product labels and nameplates. These carry important safety information.

▲ WARNING

The warnings, cautions, and instructions discussed in this instruction manual cannot cover all possible conditions or situations that could occur. It must be understood by the operator that common sense and caution are factors which cannot be built into this product, but must be used by the operator.

KNOW HOW TO USE TOOL

1. Use right tool for job. Do not force tool or attachment to do a job for which it was not designed.

2. Keep hands out of path of shear blades.

3. The maximum capacity of this machine is 1/4" mild steel or equivalent. Exceeding

capacity may be dangerous to operator and damage may occur to the machine.

4. Bolt machine to floor or sturdy stand that is bolted to floor to prevent sliding or tipping of machine.

▲ IMPORTANT

DO NOT attempt to shear hardened or stainless steel blocks or rod. You will damage or break your shear blades !

Assembly

MOUNT HANDLE

Remove two hex head bolts #7 from gear arm #3. Mount handle #4 into groove on pivot arm. Secure handle with hex head bolts. Tighten bolts securely.

INSTALLATION

Machine should be installed on a level surface, with proper lighting. Machine can be floor-mounted, stand-mounted or bench-mounted. Be sure to provide clearance for handle bar rotation. Use four mounting holes on the base to bolt machine securely to floor, bench or stand (fasteners not included).

Area around machine should be clear of scraps, oil or dirt. Apply a suitable non-skid material to floor.

Operation

Rotating handle #4 operates the shear. Be sure to keep hands clear of shear when rotating handle. The maximum capacity of the machines is 1/4" mild steel.

SHEARING PLATE AND FLAT BARS

1. Adjust hold-down plate #11 so that

KAKA Industrial®

workpiece can lie horizontally between shear blades. Place workpiece between blades #14 and #19 and underneath hold-down plate. Adjust hold-down plate to be positioned at the top surface of the workpiece, with the workpiece held horizontally. Secure the hold-down plate in position by tightening it.

2. Support workpiece between blades and underneath the hold down plate at position where cut is desired. Pull handles #4 forward with both hands until blade cuts through workpiece.

▲ CAUTION

Do not reach in back of shear to grasp fall out piece.

Shear thicker material is done by "snapping" crank handles so that upper blade impacts workpiece.

Upper blade is mounted at an angle so that workpiece can be sheared in small increments. To minimize distortion, approximately 5/8" of workpiece should be sheared with each impact.

SHEARING ROUND BARS

Round bars up to $\frac{1}{2}$ " diameter can be cut with this shear.

Place bar through holes in face of upper blade #19 and die #2. Position bar where cut is desired and pull handle #4 forward until bar is cut.

SHEAR BLADES

Always keep shear blades lubricated and clean of any dirt or rust. Abrasive particles on blades will drastically reduce life of blades. These blades should be sharpened according

to industry standards by a competent grinding service only.

▲ NOTE

If the material seems too thick or too hard, do not force the shear ! Instead, use a metal-cutting bandsaw to cut the workpiece.

Maintenance

1. Consult manual for specific maintaining and adjusting procedures.
2. Keep tool lubricated and clean for safest operation.
3. Remove adjusting tools. Form habit of checking to see that adjusting tools are removed before using machine.
4. Keep all parts in working order. Check to determine that the guard or other parts will operate properly and perform their intended function.
5. Check for damaged parts. Check for alignment of moving parts, binding, breakage, and mounting or any other condition that may affect a tool's operation.
6. Check the handle and base mounting bolts to ensure they are tight.
7. A guard or other damaged part should be properly repaired or replaced. Do not perform makeshift repairs. (Use parts list provided to order repair parts.)

Model HSG-8

Troubleshooting Chart

Symptom	Possible Cause(s)	Corrective Action
Machine will not shear	1. Workpiece material too thick	1. Do not exceed machine capacity of ¼" mild steel
	2. Blades too far apart or not parallel	2. Make sure hold-down plate #12 are tight and hold lower blade securely
	3. Dull blades	3. Have blades sharpened by a qualified grinding service

KAKA Industrial®

Drawing

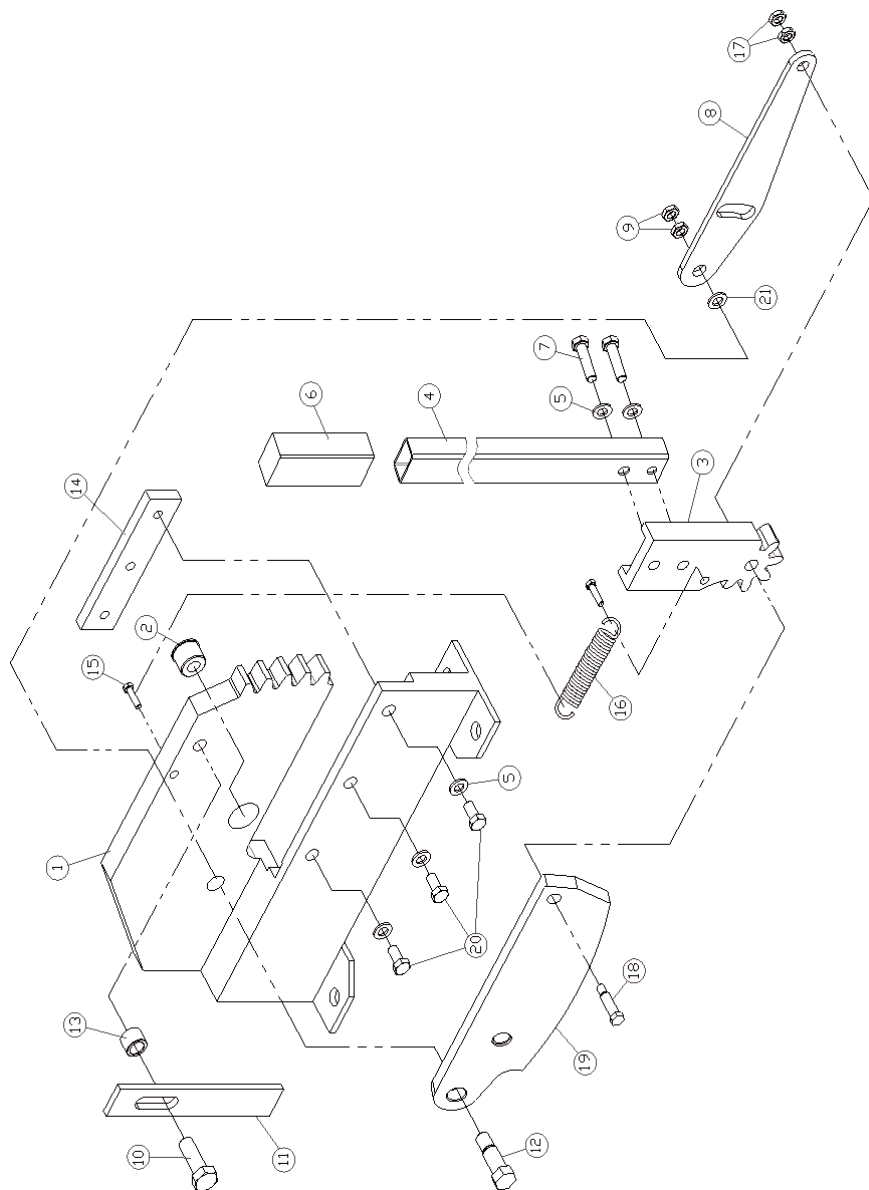

Model HSG-8

Parts List

Ref.No.	Description	QTY.
1	Base	1
2	Round die	1
3	Gear arms	1
4	Handle	1
5	Washer	5
6	Knot	1
7	Bolt M10x40	2
8	Connect plate	1
9	Nut M14	2
10	Screw M12x30	1
11	Hold down plate	1
12	Bolt	1
13	Washer	1
14	Lower blade	1
15	Bolt M8x25	2
16	Spring	1
17	Nut M10	2
18	Small shaft	1
19	Upper blade	1
20	Bolt M10x22	3
21	Washer	3

SERVICE RECORD

KAKA Industrial®

Date	Maintenance performed	Repair components require

NOTES

Stock No: 172303
Edition 1 08/2018
Copyright © 2018 KAKA



If you have any questions about the use of this product, please contact the nearest one to you as below:

KAKA INDUSTRIAL LLC
Mail:
info@kakaindustrial.com
Add: 4200 Steve Reynolds
Blvd Ste 6 Norcross,
GA 30093
U.S.A.

KAKA INDUSTRIAL LTD
Mail:
echo@kakaindustrial.com
Add: 3143 Underhill Avenue
Burnaby,
B.C V5A3C8
Canada

KANG INDUSTRIAL PTY LTD
Mail:
kang@kakaindustrial.com
Add: 3 Wayne Court
Dandenong,
VIC 3175
Australia