

# 8" MINI SHEAR/BRAKE

## ASSEMBLY AND OPERATING INSTRUCTIONS



---

## SPECIFICATIONS

Base Dimension		9" x 5"
Blade Length		8"
Maximum Cutting and Bending Length		7-7/8"
Capacity	Aluminum	1.2mm
	Copper	1.0mm
	Circuit Board	1.5mm
	Tinplate Sheet Metal	1.0mm
	Brass	1.0mm

## SAVE THIS MANUAL

You will need the manual for the safety warning and cautions, assembly instructions, operating procedures and maintenance procedures, trouble shooting, parts list and diagram. **Keep your invoice with this manual. Write the invoice number on the inside of the front cover.** Keep the manual and invoice in a safe, dry place for future reference.

## SAFETY WARNING & CAUTIONS

**WARNING:** When using electric tools, machines, or equipment, basic safety precautions should always be followed to reduce the risk of fire, electric shock, and personal injury. **READ ALL INSTRUCTIONS BEFORE USING THIS TOOL!**

1. **KEEP WORK AREA CLEAN.** Cluttered areas invite injuries.
2. **OBSERVE WORK AREA CONDITIONS.** Do not use machines or powered tools in damp, wet, or poorly lit locations. Don't expose to rain. Keep work area well lit. Do not use electrically powered tools in the presence of flammable gases or liquids.
3. **KEEP CHILDREN AWAY.** Children must never be allowed in the work area. Do not let them handle machines, tools, or extension cords.
4. **STORE IDLE EQUIPMENT.** When not in use, tools must be locked up in a dry location to inhibit rust. Always lock up tools and keep out of reach of children.
5. **DO NOT FORCE THE TOOLS.** It will do the job better and more safely at the rate for which it was intended. Do not use inappropriate attachments in an attempt to exceed the tool's capacities.

- 
6. **USE THE RIGHT TOOL FOR THE JOB.** Do not attempt to force a small tool or attachment to do the work of a large industrial tool. Do not use a tool for a purpose for which it was not intended.
  7. **DRESS PROPERLY.** Do not wear loose clothing or jewelry as they can be caught in moving parts. Protective, electrically non-conductive clothes and non-skid footwear are recommended when working. Wear restrictive hair covering to contain long hair.
  8. **USE EYE AND EAR PROTECTION.** Always wear ANSI approved chemical splash goggles when working with chemicals. Always wear ANSI approved impact safety goggles at other times. Wear a full-face shield if you are producing metal filings or wood chips. Wear an ANSI approved dust mask or respirator when working around metal, and chemical dusts and mists.
  9. **DO NOT ABUSE THE POWER CORD.** Do not yank it to disconnect it from the receptacle. Do not carry tools by the cord.
  10. **DO NOT OVERREACH.** Keep proper footing and balance at all times. Do not reach over or across running machines.
  11. **MAINTAIN TOOLS WITH CARE.** Keep tools sharp and clean for better and safer performance. Follow instructions for lubricating and changing accessories. The handles must be kept clean, dry, and free from oil and grease at all times.
  12. **DISCONNECT POWER.** Unplug when not in use, before servicing, and when changing accessories.
  13. **STAY ALERT.** Watch what you are doing; use common sense. Do not operate any tool when you are tired.
  14. **REPLACEMENT PARTS AND ACCESSORIES.** When servicing, use only identical replacement parts. Use of any other parts will void the warranty. Only use accessories intended for use with this tool. Approved accessories are available from the distributor.
  15. **DO NOT OPERATE TOOL IF UNDER THE INFLUENCE OF ALCOHOL OR DRUGS.** Read warning labels on prescriptions to determine if your judgment of reflexes are impaired while taking drugs. If there is any doubt, do not operate the tool.

**Note:** The warning and instructions contained in this instruction manual cannot cover all possible conditions and situations that may occur when using this product. It must be understood that common sense and caution are factors, which cannot be built into this product. These factors must be supplied by the person whom operating this piece of equipment.

---

## UNPACKING

<b>Ref</b>	<b>Item Description</b>	<b>Quantity</b>
N/A	Shear/Brake Assembly	1
1	Bolt & Nut Set (for mounting)	4
4	Allen Wrench Set	2
9	Bending Tool	1
10	Bending Tool	1
11	Bending Tool	1
12	Bending Tool	1
N/A	Handle Assembly	1

## ASSEMBLY

Your Shear/Brake comes assembled with the BENDING TOOL (#8) already installed. To complete assemble and prepare your Shear/Brake for use, follow the Steps below.

### **Mounting to a Wood Workbench**

- Step 1:** Measure the thickness of your workbench. It is suggested that to securely mount your Shear/Brake to a wooden workbench, you mount lengths of wood underneath the mounting points.
- Step 2:** If the supplied BOLT & NUT SET (#4) is not in the correct length for your needs, purchase four bolts, nuts, and flat washers the appropriate length for your workbench plus 1" of length for the Shear/Brake.
- Step 3:** Mark and drill holes through the workbench, using the BASE (#5) as a template, for the four Mounting Holes on the BASE of the Shear/Brake.
- Step 4:** Position the Shear/Brake on your workbench and line up the holes you drilled in Step 3 with the Mounting Holes in the BASE.

---

**Step 5:** Insert the BOLT & NUT SET (#1) into the Mounting Holes and through the workbench as shown in Figure 1.

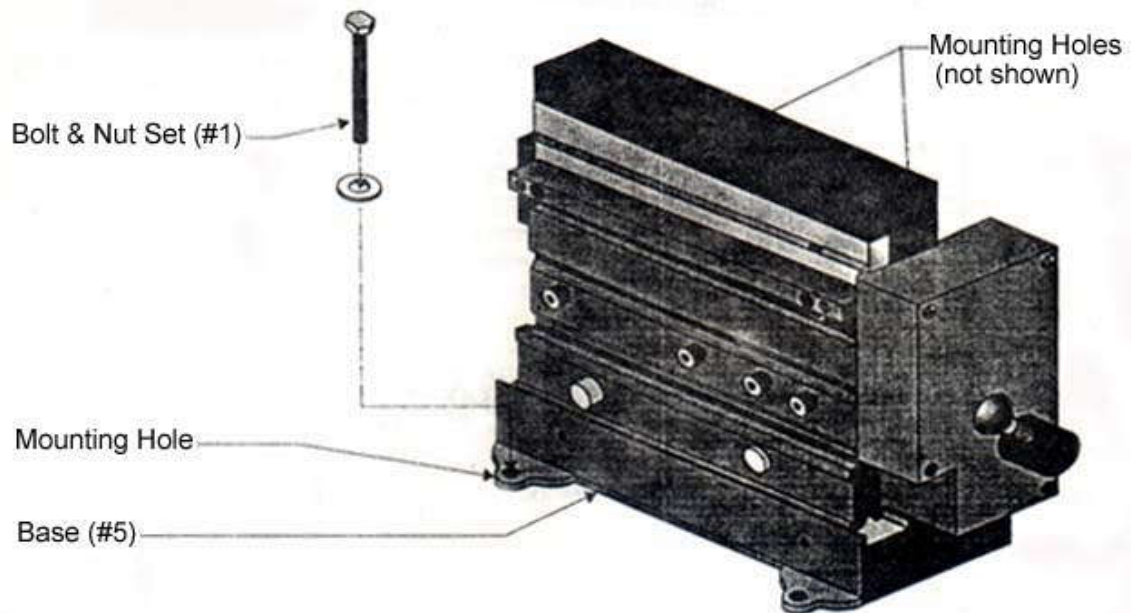

**Figure 1 -- Mounting Shear/Brake to a Wood Workbench**

**Step 6:** Tighten Bolts.

### **Mounting to a Metal Workbench**

**Step 1:** Measure the thickness of your workbench. It is suggested that a metal reinforcing plate be cut and ready to mount beneath the workbench for Step 7.

**Step 2:** If the supplied BOLT & NUT SET (#4) is not in the correct length for your needs, purchase four bolts, nuts, and flat washers the appropriate length for your workbench plus 1" of length for the Shear/Brake.

**Step 3:** Mark and drill holes through the workbench, using the BASE as a template, for the four Mounting Holes on the Base of the Shear/Brake.

**Step 4:** Mark and drill the reinforcing plate, using the BASE of the Shear/Brake as a template, for the four Mounting Holes on the BASE of the Shear/Brake.

**Step 5:** Position the Shear/Brake on your workbench and line up the holes you drilled in Step 3 with the holes in the BASE.

**Step 6:** Mount the Shear/Brake to the workbench. Refer to Figure 1.

**Step 7:** Remember to attach the reinforcing plate underneath the workbench then thread on the nuts and tighten the bolts.

### **Handle Assembly**

**Step 1:** Loosen the Knob located at the Handle Pivot on the right side of the Shear/Brake.

---

**Step 2:** Insert the HAND LEVER (#2) into the Handle Pivot, grooved end first. When the groove in the HAND LEVER is centered in the Handle Pivot, tighten the Knob as shown in Figure 2.

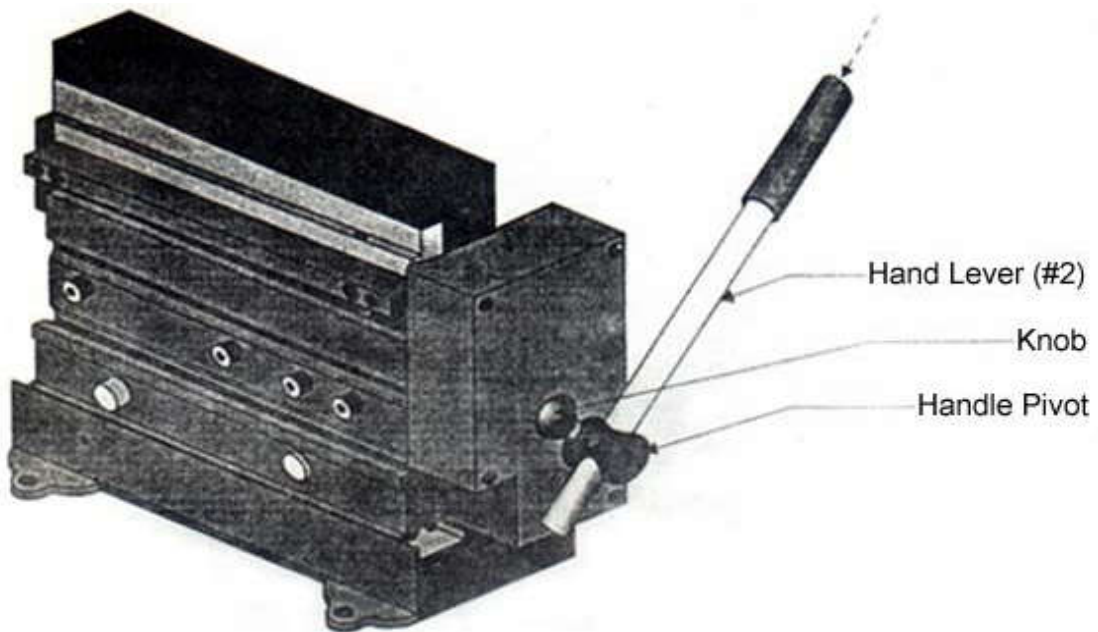

**Figure 2 -- Hand Lever Installation**

### **Bending Tool Adjustment and Removal**

The BENDING TOOL (#8-12) come in various widths and can be used for varying sizes of box and pan forming. When forming a smaller box or pan, choose the desired size BENDING TOOL finger, center it and remove the others. See the Steps below for adjustment instructions.

**Step 1:** Loosen the HEX HEAD SCREWS (#17) holding the BENDING TOOL fingers in place.

**Step 2:** Remove any unneeded BENDING TOOL fingers by sliding them out the left of the Shear/Brake as shown in Figure 3.

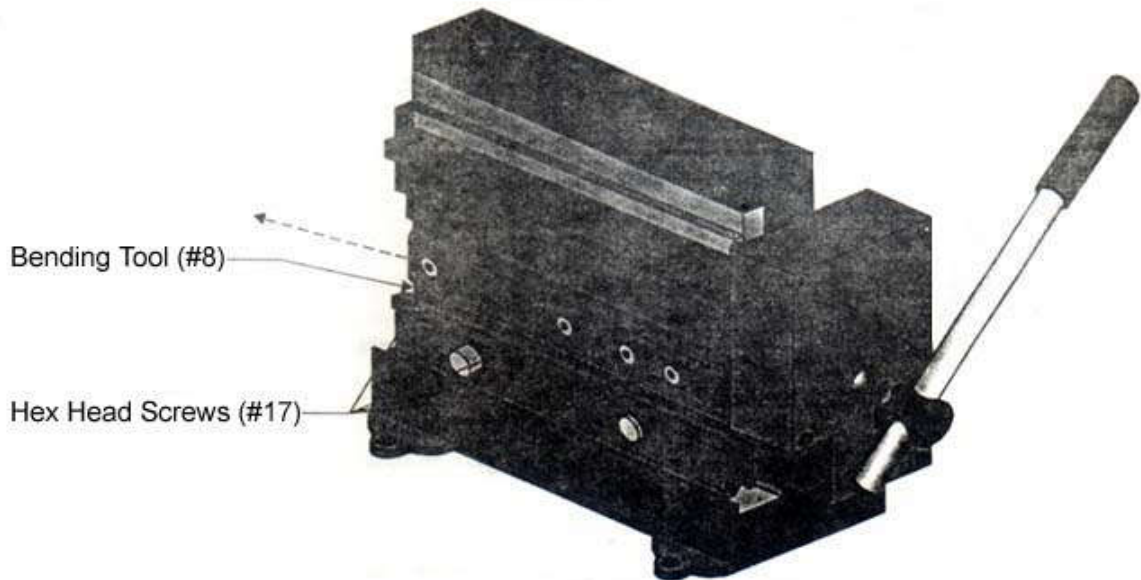

**Figure 3 -- Bending Tool Removal**

**Step 3:** Insert any needed BENDING TOOLS appropriate for the job you will be doing behind the CLAMPING BAR (#16).

**Step 4:** Lower the HAND LEVER (#2) to lower the installed BENDING TOOLS. This will adjust the alignment of the BENDING TOOLS.

**Step 5:** Tighten the HEX HEAD SCREWS.

### **Bending Prism Adjustment**

You can adjust the radius of the bend you will make by changing the BENDING PRISM (#13) as described below.

**Step 1:** Loosen the CLAMP SCREW (#15) located on the backside of the Shear/Brake as shown in Figure 4.

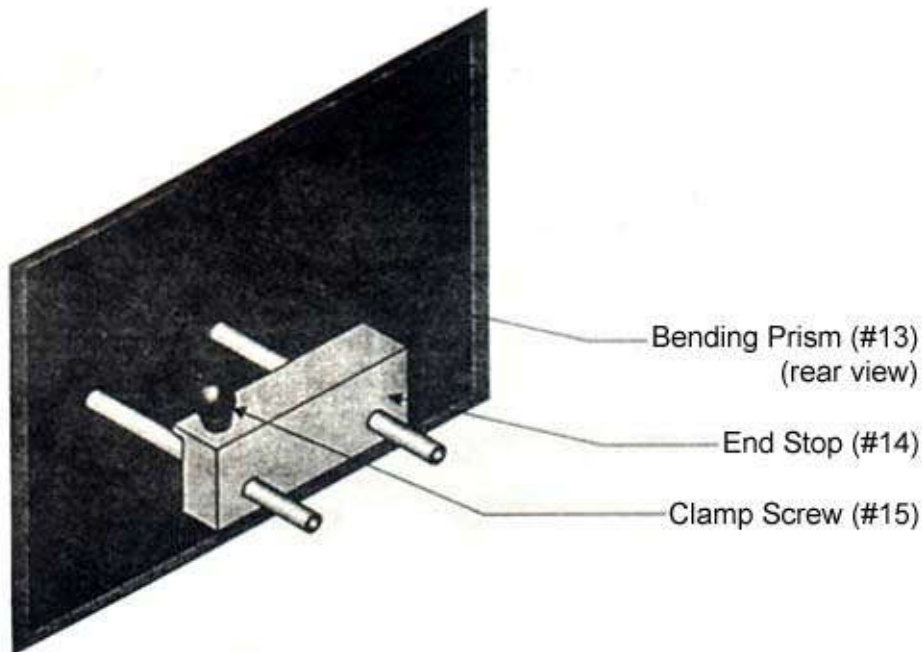
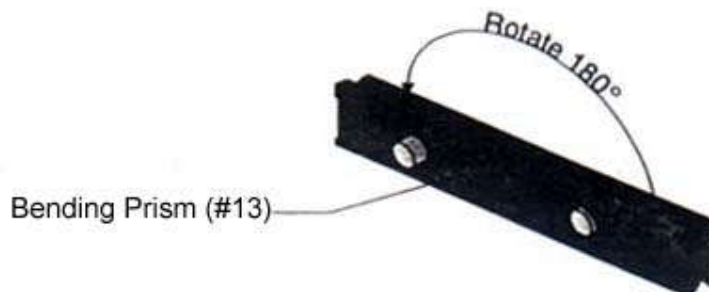

**Figure 4 -- Loosening the Clamp Screw**

**Step 2:** Raise the HAND LEVER to raise the Bending Assembly.

**Step 3:** Lift the BENDING PRISM out of the groove in the BASE (#5). Pull the BENDING PRISM forward out of the END STOP (#14).

**Step 4:** Rotate the BENDING PRISM 180° to use the optional radius as shown in Figure 5. Fit the BENDING PRISM back into the groove.



**Figure 5 -- Rotating the Bending Prism**

**Step 5:** Slide the END STOP (#14) back onto the BENDING PRISM (#13). Tighten the CLAMP SCREW (#15).

### **Removal and Installation of Upper Cutter**

**Step 1:** Lower the HAND LEVER to lower the LOWER CUTTER (#7).



---

**Step 2:** Loosen the four MOUNTING SCREWS (#19) from the Upper CUTTER HOLDER (#20). Completely remove the two MOUNTING SCREWS (#19) holding the UPPER CUTTER (#6) in place.

**Step 3:** Remove the UPPER CUTTER as shown in Figure 6. There are four cutting edges on the UPPER CUTTER. If you have not used all four cutting edges, you can rotate the UPPER CUTTER to expose a sharp edge and reinstall without purchasing a replacement UPPER CUTTER.

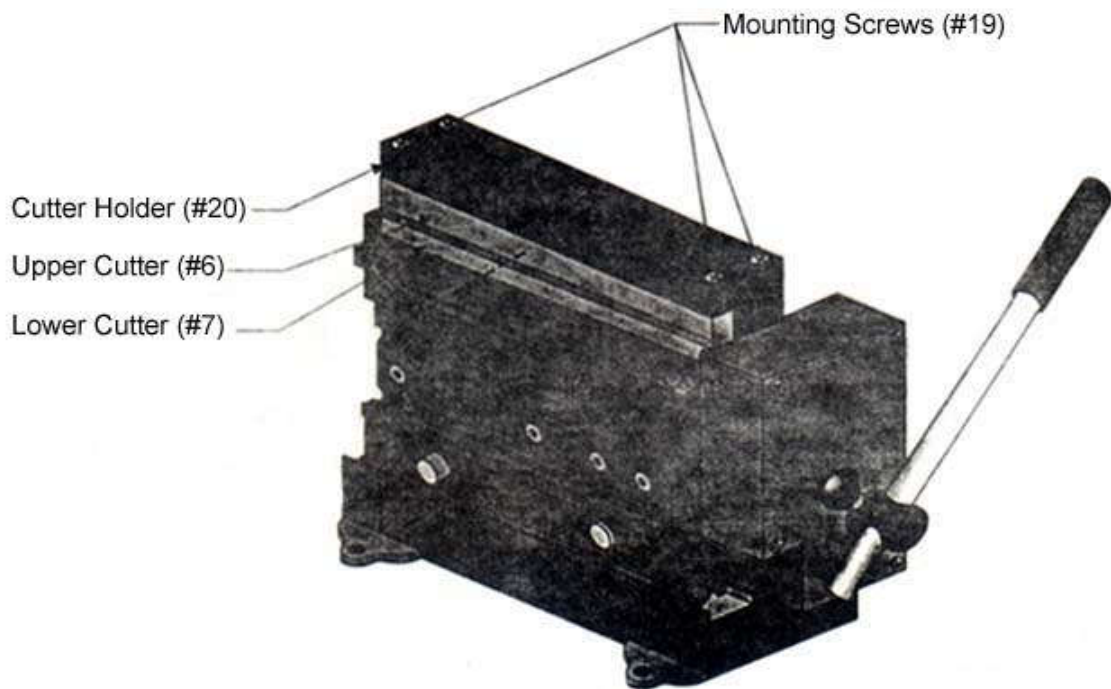

**Figure 6 -- Removing the Upper Cutter**

**Step 4:** Align the UPPER CUTTER (#6) so that it is flush with the LOWER CUTTER (#7) and secure with its MOUNTING SCREWS (#19).

**Notice:** The screws that hold the UPPER CUTTER (#6) must be tightened before tightening the CUTTER HOLDER Screws; otherwise, the cutter will jam.

---

## Removal and Installation of Lower Cutter

**Step 1:** Raise the HAND LEVER to raise the LOWER CUTTER.

**Step 2:** Loosen and remove the two MOUNTING SCREWS (#22) for the LOWER CUTTER as shown in Figure 7.

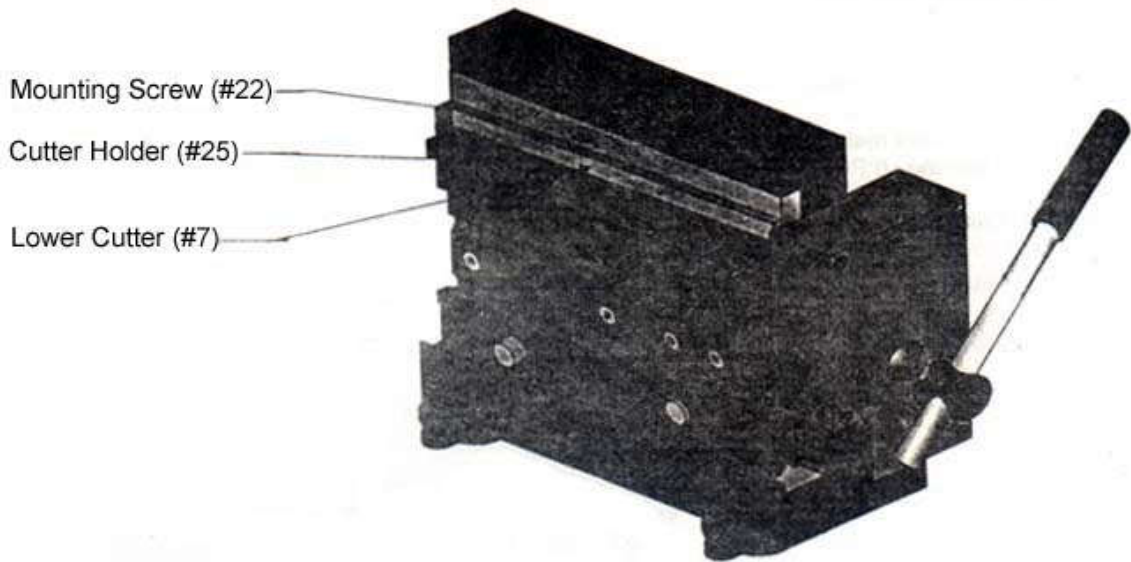

**Figure 7 -- Removing the Lower Cutter**

**Step 3:** Press the flat of the LOWER CUTTER against the UPPER CUTTER with your thumb and lower the HAND LEVER. This will separate the LOWER CUTTER from the CUTTER HOLDER (#25).

**Step 4:** Remove and replace the LOWER CUTTER. There are four cutting edges on the LOWER CUTTER. If you have not used all four cutting edges, you can rotate the LOWER CUTTER to expose a sharp edge and reinstall without purchasing a replacement LOWER CUTTER.

**Step 5:** Press the LOWER CUTTER down against the CUTTER HOLDER.

**Step 6:** Raise the HAND LEVER. Insert and tighten the MOUNTING SCREWS.

---

## OPERATION

### Shearing

**Step 1:** Make sure the material you will be shearing is within the capacity of the tool. Do not use material that is thicker than the rated capacity for your Shear/Brake.

**Step 2:** Scribe the cutting mark on the material.

**Step 3:** Slide the material between the UPPER CUTTER (#6) and the LOWER CUTTER (#7) so that the UPPER CUTTER is positioned directly above the mark as shown in Figure 8.

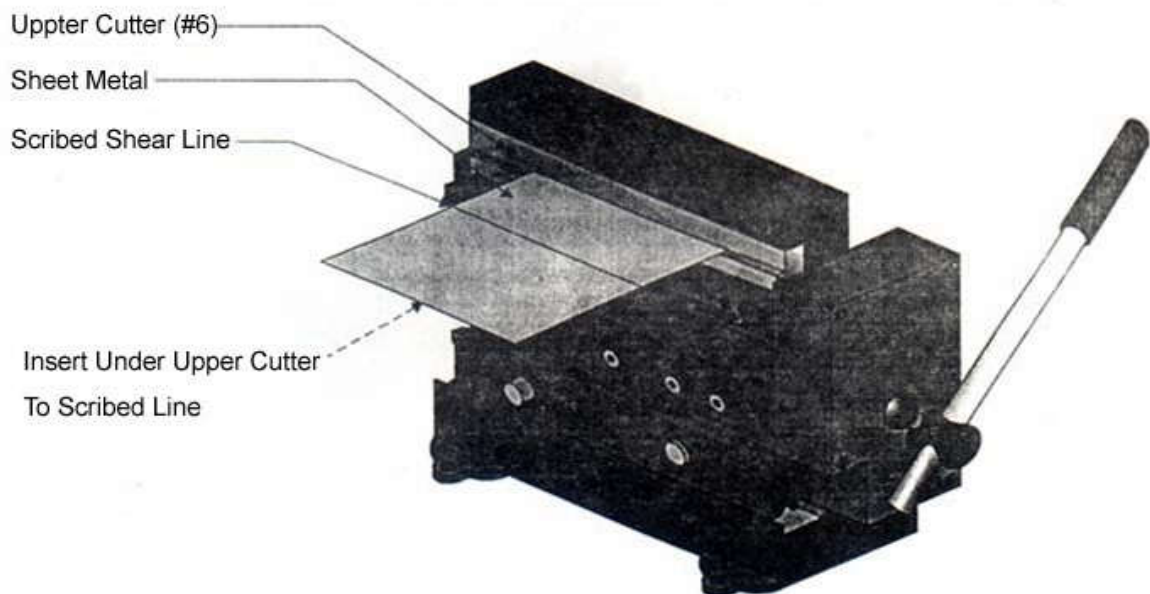

**Figure 8 -- Inserting Scribed Sheet Metal**

**Step 4:** While holding the material steady, lower the HAND LEVER (#2) until the material has been cut.

---

## **Angle Bending**

**Step 1:** Make sure the material you will be bending is within the capacity of the tool. Do not use material that is thicker than the rated capacity for your Shear/Brake.

**Step 2:** Use the appropriate BENDING TOOLS and BENDING PRISM radius for your needs. Refer to the **ASSEMBLY** Steps for adjustment.

**Step 3:** Mark the work place where you want to bend the material.

**Step 4:** Place material above the BENDING PRISM (#13).

**Step 5:** Align the bending mark with the front edge of the BENDING TOOL (S).

**Step 6:** Lower the HAND LEVER (#2) until the desired angle has been formed. Use a protractor or other measuring tool to ensure accuracy.

---

## Pan forming

The Hand Brake Roll can be used to make various sizes of pans.

**Step 1:** Pre-measure and cut your material before bending, Notch the corners according to the desired lip height as shown in Figure 9.1.

**Step 2:** Insert material between the BENDING TOOL (S) and BENDING PRISM. Bend the material until a 90-degree angle has been formed as shown in Figure 9.

**Step 3:** Rotate the material 90-degree counterclockwise. Allow the completed side to extend just beyond the dies. Bend the second side.

**Step 4:** Repeat Step 3 for the third side.

**Step 5:** Rotate to the final side, and insert work piece between the dies. Your formed sides will be on the outside of the dies.

**Step 6:** Before bending tap one corner nearer to the middle of the machine as shown in Figure 9.3. This will allow the material to clear the UPPER DIE when raised.

**Step 7:** Bend the fourth side.

**Step 8:** Using a block or piece of wood, tap the corner of material back into place.

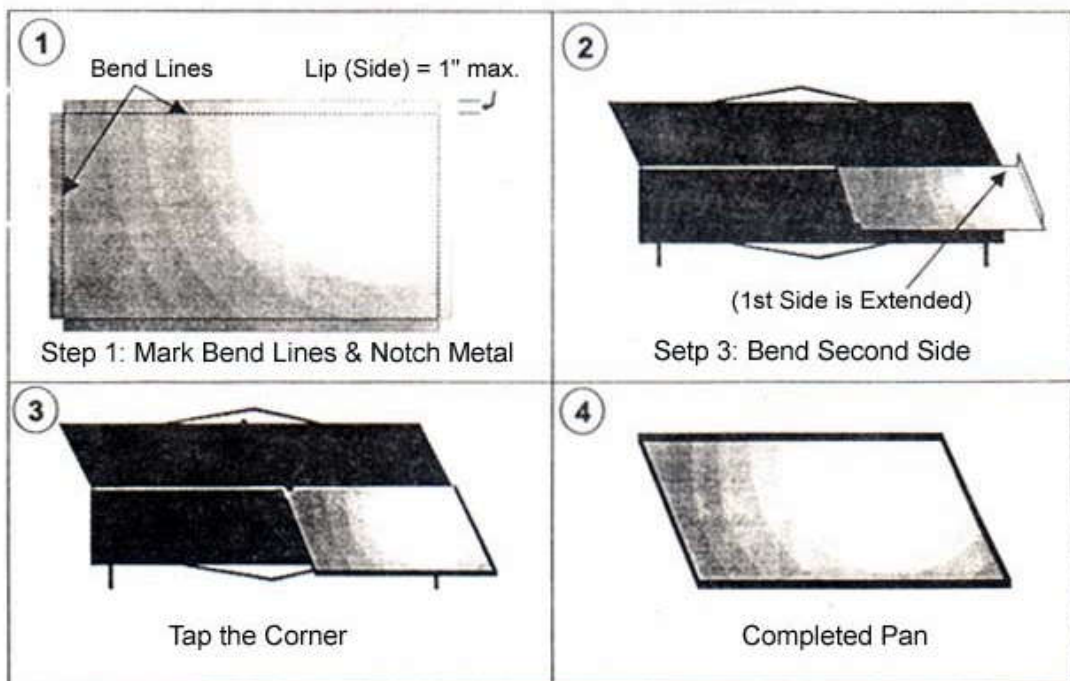

Figure 9 -- Pan Forming

---

## Radius Bending

Radius Bending is most commonly used to make cylinders and cones, as shown in Figure 10. Both shapes are formed by making a series of small, closely spaced bends in the work piece.

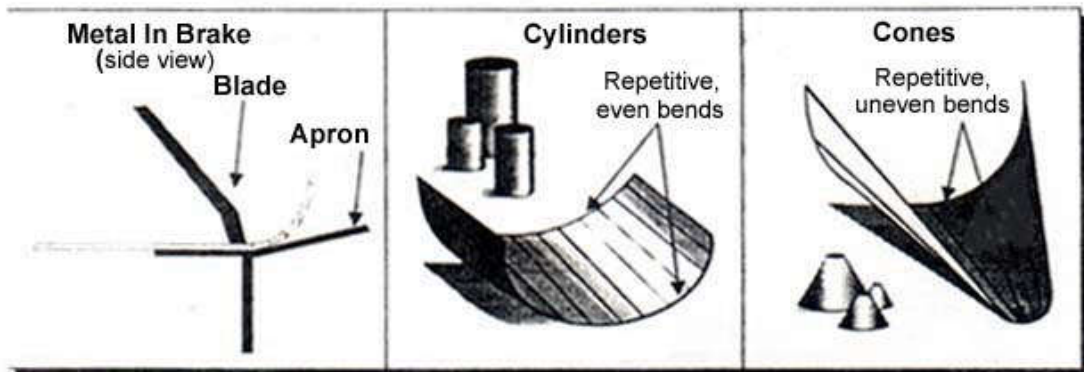

Figure 10 -- Radius Bending

For cylinders, the bends are evenly spaced, i.e. every bend is identical.

For cones, simply move one side of your stock out further than the other every time you make a bend.

---

## PARTS LIST

Item #	Description	Quantity
1	Bolt and Nut Set	4
2	Hand Lever	1
3	Hex Head Screw	1
4	Allen Wrench Set	2
5	Base	1
6	Upper Cutter	1
7	Lower Cutter	1
8	Bending Tool	1
9	Bending Tool	1
10	Bending Tool	1
11	Bending Tool	1
12	Bending Tool	1
13	Bending Prism	1
14	End Stop	1
15	Clamp Screw	1
16	Clamping Bar	1
17	Hex Head Screw	4
18	----	--
19	Mounting Screw	4
20	Cutter Holder	1
21	Locknut	2
22	Mounting Screw	2
23	Slide	1
24	Hex Head Screw	4
25	Cutter Holder	1
26	T-Block	1
27	Handle Bushing	1
28	Mounting Screw	4

# ASSEMBLY DIAGRAM

