

ocean master & plantation MAX dual cantilever

“easy drive” crank w/ telescoping mast

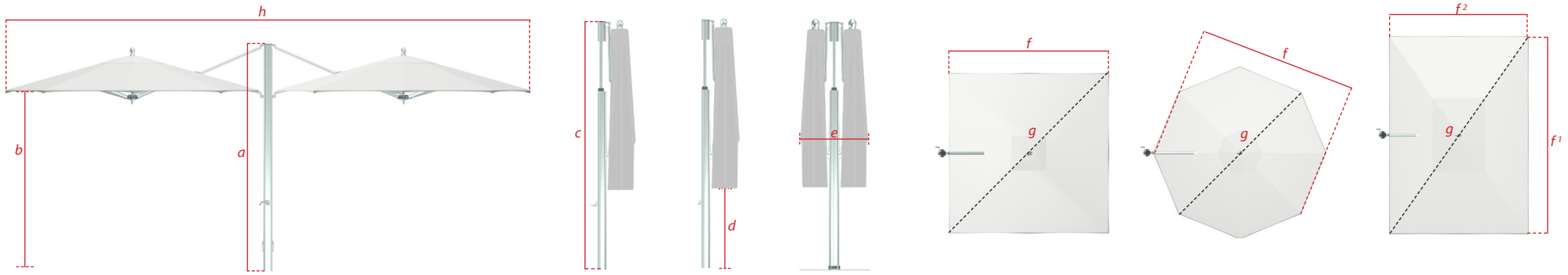
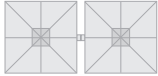
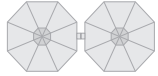
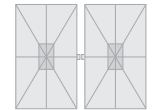

		mast height (open position)	canopy clearance	mast height (telescope closed position)	table clearance (telescope)	closed parasol width (closed include crank handle)	flat to flat	point to point	parasol width end to end (open position)
MAX dual cantilever	sizes [ft/m]	a (in/cm)	b (in/cm)	c (in/cm)	d (in/cm)	e (in/cm)	f (in/cm)	g (in/cm)	h (in/cm)
 square	8.0' x 16.0' 2.4m x 4.9m	102 / 260	87 / 220	123 / 313	53 / 134	42 / 107	96 / 244	134 / 341	206 / 524
	10.0' x 20.0' 3.0m x 6.0m	102 / 260	84 / 213	128 / 326	40 / 101	36 / 92	121 / 308	168 / 427	251 / 638
	12.0' x 24.0' 3.65m x 7.4m	108 / 275	81 / 205	131 / 333	31 / 78	38 / 97	143 / 364	201 / 511	300 / 762
	13.0' x 26.0' 4.0m x 7.9m	112 / 285	91 / 231	145 / 369	31 / 78	41 / 97	153 / 389	215 / 547	318 / 808
 octagon	9.0' x 18.0' 2.75m x 5.4m	102 / 260	84 / 213	128 / 326	63 / 160	44 / 112	103 / 262	110 / 280	232 / 590
	11.0' x 22.0' 3.4m x 6.8m	102 / 260	80 / 203	133 / 337	54 / 137	41 / 105	121 / 308	132 / 336	276 / 702
	13.0' x 26.0' 4.0m x 8.0m	106 / 270	88 / 233	140 / 356	51 / 129	46 / 117	142 / 361	154 / 392	319 / 811
 rectangle	16.0' x 12.0' 4.9m x 3.65m	99 / 252	84.5 / 215	118 / 300	32 / 81	36 / 92	f ¹ X f ² 97, 145 / 247, 369	174 / 442	191 / 486
	20.0' x 14.0' 6.0m x 4.25m	106 / 270	89 / 226	130 / 331	28 / 71	34 / 87	f ¹ X f ² 120, 171 / 305, 435	209 / 531	252 / 641

Dimension Tolerances ± 2"
Dimensions shown correspond to indicated lift system
Options are subject to change without notice
Some options are only available in certain sizes and shapes

2" security base stem height not included

ocean master & plantation MAX dual cantilever auto-lift assist piston system

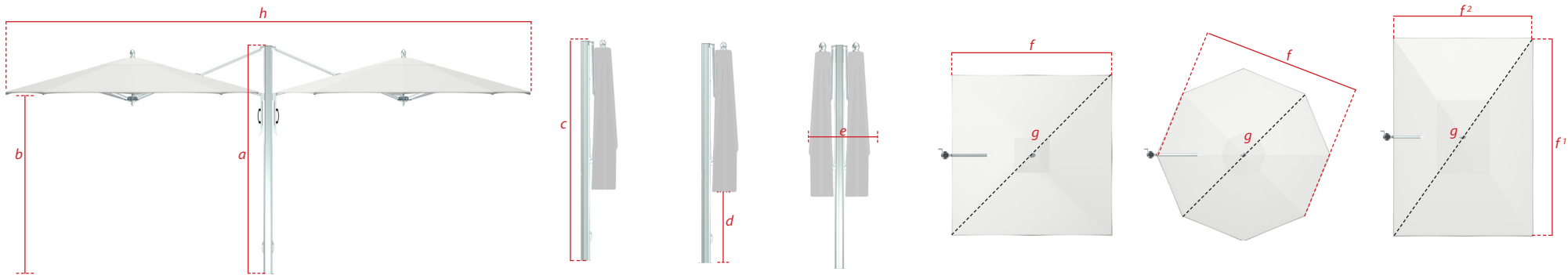

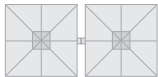
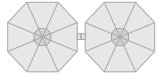
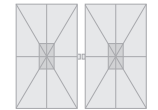
		<i>mast height (open position)</i>	<i>canopy clearance</i>	<i>mast height (telescope closed position)</i>	<i>table clearance (telescope)</i>	<i>closed parasol width (closed include crank handle)</i>	<i>flat to flat</i>	<i>point to point</i>	<i>parasol width end to end (open position)</i>
<i>MAX dual cantilever</i>	<i>sizes [ft/m]</i>	<i>a (in/cm)</i>	<i>b (in/cm)</i>	<i>c (in/cm)</i>	<i>d (in/cm)</i>	<i>e (in/cm)</i>	<i>f (in/cm)</i>	<i>g (in/cm)</i>	<i>h (in/cm)</i>
square 	8.0' x 16.0' 2.4m x 4.9m	107 / 172	90 / 229	108 / 274	37 / 94	33 / 84	96 / 244	134 / 340	206 / 523
	10.0' x 20.0' 3.0m x 6.0m	107 / 172	87 / 221	107 / 172	18 / 46	27 / 69	121 / 307	168 / 427	251 / 638
octagon 	9.0' x 18.0' 2.75m x 5.4m	105 / 267	87 / 221	105 / 267	41 / 104	35 / 89	103 / 262	110 / 279	232 / 589
	11.0' x 22.0' 3.4m x 6.8m	107 / 172	86 / 218	112 / 285	28 / 71	32 / 81	121 / 262	132 / 335	276 / 701
rectangle 	16.0' x 12.0' 4.9m x 3.65m	107 / 172	90 / 229	110 / 279	21 / 53	27 / 69	<i>f</i> X <i>f</i> 97, 145 / 246, 368	174 / 442	191 / 485

Dimension Tolerances ± 2"
 Dimensions shown correspond to indicated lift system
 Options are subject to change without notice
 Some options are only available in certain sizes and shapes

2" security base stem height not included

ocean master & plantation MAX dual cantilever (cont.)

vent and pocket options

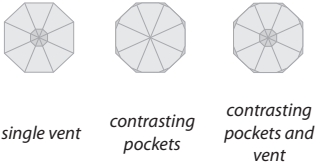

single vent contrasting pockets contrasting pockets and vent

profile options



market fishtail* valance straight valance scalloped

panel options



single solid color alternating panels alternating panel & alternating valance alternating panel and matching valance

canopy options



binding accent border

lifting system options

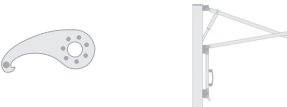

crank system † auto lift assist system (no telescoping)

finial



MAX acorn aluminum

finish options

standard

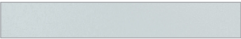

polished aluminum

powder coat



textured bright white sea shell white espresso ash grey hammered bronze jet black

aluma-TEAK



natural java weathered aspen white

Dimension Tolerances +.2"
 Dimensions shown correspond to indicated lift system
 Options are subject to change without notice
 Some options are only available in certain sizes and shapes