

COMPOSIZIONE BASE 3 MODULI - ASSEMBLY OF A BASE WITH 3 MODULES

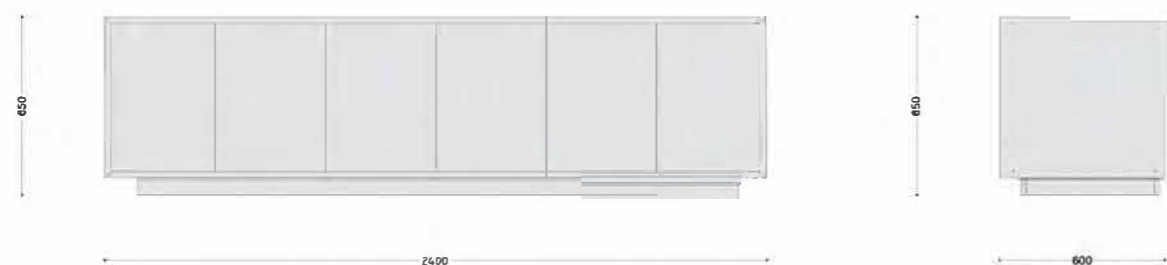

Struttura in acciaio zinco magnesio e alluminio (Magnesit), verniciatura nero RAL 9004 alte temperature testurizzato.
6 ante a battente con maniglia ad incasso gola, apertura 125° a sgancio rapido e chiusura blumotion.
Misure 2400x600x650 h - peso 140 kg.

*Structure in zinc magnesium steel and aluminium (Magnesit), black RAL 9004 high temperature, textured painting.
6 swing doors with recessed handles, fast release 125° opening and blumotion latch.
Dimensions: 2400x600x650 h - weight 140 kg.*

COMPOSIZIONE BASE 2 MODULI - ASSEMBLY OF A BASE WITH 2 MODULES



Struttura in acciaio zinco magnesio e alluminio (Magnesit), verniciatura nero RAL 9004 alte temperature testurizzato.
4 ante a battente con maniglia ad incasso gola, apertura 125° a sgancio rapido e chiusura blumotion.
Misure 1600x600x650 h - peso 95 kg.

*Structure in zinc magnesium steel and aluminium (Magnesit), black RAL 9004 high temperature, textured painting.
4 swing doors with recessed handles, fast release 125° opening and blumotion latch.
Dimensions: 1600x600x650 h - weight 95 kg.*

MODULI DISPONIBILI - AVAILABLE MODULES



Modulo Barbecue

Struttura in acciaio alluminato/acciaio inox, verniciatura nero RAL 9004 alte temperature testurizzato.
Bruciatori a Gas con potenza totale 6 kw con sistema a irradiazione Fire Core esclusivo che sfruttando l'abbinamento tra speciali bruciatori e deflettori che agiscono per irradiazione, permette di avere una temperatura uniforme su tutta la superficie con caratteristiche di bassi consumi ed efficienza sviluppata dai bruciatori da 2kw. Misure 800x600x250 h - peso 52 kg.

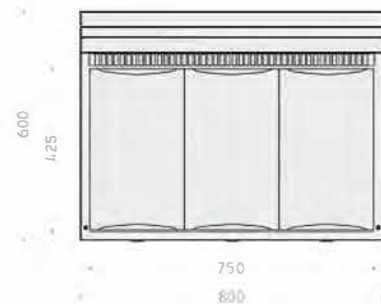

Barbeque module

*Aluminium/Stainless steel structure, black RAL 9004 high temperature, textured painting.
6kw total potency gas burners with exclusive irradiance Fire Core system, based on the combined use of special burners and deflectors, which allows the maintaining of a stable temperature all over its surface. The system is characterised by low consumption and efficiency, guaranteed by 2kw burners. Dimensions 800x600x250 h - weight 52 kg.*

MODULI DISPONIBILI - AVAILABLE MODULES



Modulo Piano cottura ad induzione

4 Zone cottura da 1800/3000 W
Potenza massima assorbita regolabile a 5 livelli (2.8 kW / 3.5 kW / 4.5 kW / 5.8 kW / 7 kW)
Funzione Booster - 2 zone Bridge
Vetroceramica nero sp 4mm
Misure 800x600x250 h - peso 39 kg.

Induction hob module

*4 cooking zones 1800/3000 W
Maximum power input adjustable to 5 levels (2.8 kW / 3.5 kW / 4.5 kW / 5.8 kW / 7 kW)
Booster function - 2 Bridge zones
4 mm glass-ceramic
Dimensions 800x600x250 h - weight 39 kg.*

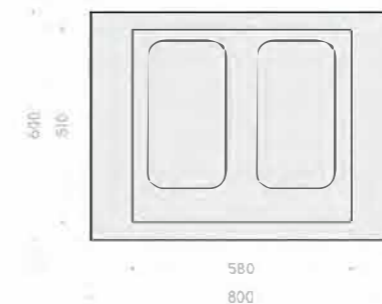

Modulo Lavello

Vaschetta (Foster) in acciaio inox AISI 304 - Sottotop
Finitura spazzolato - 1 vasca 340x400 mm
Miscelatore monocomando per lavello con canna piatta girevole. Flessibili di alimentazione F3/8".
Finitura acciaio inox.
Misure 800x600x250 h - peso 37 Kg.

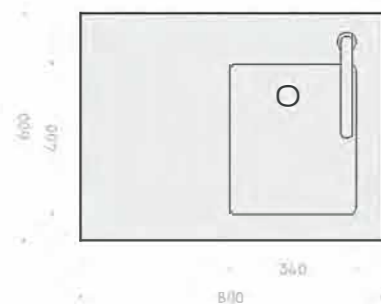

Sink module

*Stainless steel AISI 304 sink (Foster) - Undermount sink
Brushed finish- 1 basin 340X400 mm
Single-lever sink mixer, flat swivel spout. 3/8" female connection hoses.
Stainless steel finishing.
Dimensions 800x600x250 h - weight 37 kg.*



Modulo piano lavoro

Modulo neutro con piano in gress spessore 9 mm colore effetto cemento.
Misure 800x600x250 h - peso 34 kg.

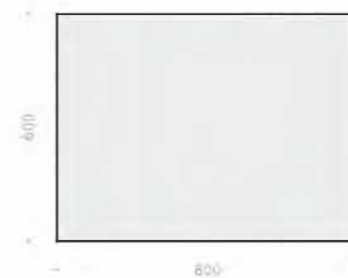

Neutral countertop module

Neutral module with gress top 9 mm thick concrete effect color. Dimensions 800x600x250 h - weight 34 kg.

OPTIONAL DISPONIBILI - *OPTIONALS AVAILABLE*



Snack

piano a sospensione con top in gress
misura disponibili:
1600x350x130 - peso 30 kg, cucina 2 moduli
2400x350x130 - peso 48 kg, cucina 3 moduli

Snack bar

Hanging kitchen gres top:
dimensions 1600x350x130 - weight 30 kg, 2 modules
dimensions 2400x350x130 - weight 48 kg, 3 modules

OPTIONAL DISPONIBILI - *OPTIONALS AVAILABLE*



Cantina

Capacità: 25 litri - 8 bottiglie
Temperatura regolabile da 8°C a 18°C. Schermo LED
Funzionamento termoelettrico, sistema antivibrazione
4 ripiani in legno.

Wine cellar

Volume capacity: 25 liters-8 bottles
Adjustable temperature from 8°C to 18°C. LED Screen
Thermoelectric functioning, anti-vibration system
4 wooden shelves.



Penisola

piano a sospensione con top in gress
misure 1200x950x130 - peso 54 kg

*abbinabile solo allo snack e disponibile solo
alla base 3 moduli

Peninsula

Hanging gres top dimensions 1200x950x130 - weight 54 kg

**only compatible with the snack and just available in the
base with 3 modules*



Frigorifero mini bar

Capacità volume 25 litri
peso netto 12 kg

Minibar fridge

Volume capacity 25 liters
Net weight 12 kg

Kit luci

kit illuminazione a led nascosto a battiscopa
ip 65 luce calda 3000K alimentazione 220w. Telecomando con
dimer di intensità di illuminazione.

Lights kit

*led lighting kit hidden by skirting board ip 65 warm light 3000K,
220w power supply. Remote control with lighting
intensity dimer.*



Ice maker

Capacità di produzione giornaliera: 12 kg
Capacità vassoio d'acqua: 2.1L
Ciclo di produzione: 10 a 13 minuti
2 formati di ghiaccio potenza: 150W

Ice maker

Daily production capacity: 12 kg
Water tank capacity: 2.1L
Production cycle: 10 to 13 minutes
2 ice power formats: 150W



Magnesit

Gress 9 mm

Glass-ceramic
4mm

Brushed
stainless steel