

## D.153.1 ARMCHAIR — GIO PONTI 1953 / 2012

1—  
2



Designed in 1953, the D.153.1 armchair is part of the furniture of Gio Ponti's private house in via Dezza in Milan. This re-edition is produced by Molteni&C based on the original drawings from the ponti archives. Brass structure, cover in bicolour white-blue leather or "Punteggiato" fabric, designed by Ponti for Rubelli in 1934. The fabric reinterprets the age-old technique of velvet-weaving, bringing it up to date with contemporary patterns, such as close sequences of staggered disks with various gradations of colour. Exhibited at the Salone del Mobile 2012, the D.153.1 chair enriches the Gio Ponti furnishing Collection.

### DATASHEET

REGISTERED  
DESIGN

IX.2018

Dimensions in centimeters and inches. The right to discontinue and make changes is reserved. This information is based on the latest product information available at the time of printing.

**D.153.1**  
**ARMCHAIR**—  
GIO PONTI  
1953 / 2012

**FINISHES**

Made with brass frame.

**COVERS**

- Two-coloured leather White L212/blue L100  
Paper white S1211/sand S1222  
Dove grey L209/dark brown L216
- *Punteggiato* velvet designed by Gio Ponti in 1934, in colours from the Molteni Collection range
- Fabrics and leathers from the Molteni Collection range

The remove of cover must be done by a skilled person.

Available in fire-resistant version (TB117 and BS5852).

**TECHNICAL INFORMATION**

**UPHOLSTERED STRUCTURE**

Frame in solid Fir (Picea abies) with elastic straps, covered in custom polyurethane in different thicknesses.  
Bonded velveteen lining.

**ARMREST**

In solid Fir covered in custom polyurethane. Bonded velveteen lining.

**LEGS**

In heat-sealed steel with a satin brass finish. Feet in non-slip plastic.

**OUTER COVER**

(See attached card, specific for each cover).

**Note: Covers are difficult to remove.**

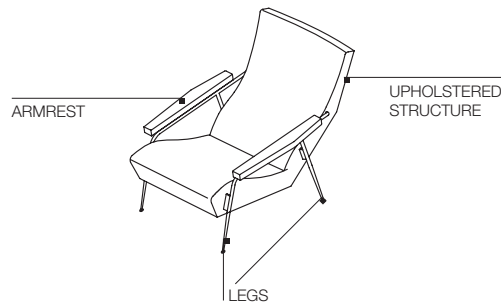

**DIMENSIONS**

**armchair**

**D.153.1**

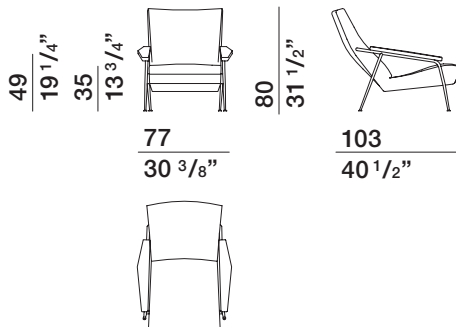

**DATASHEET**

REGISTERED  
DESIGN

IX.2018