



DESCRIPTION

The Tosca collection is simultaneously warm and inviting, stylish and intriguing. An elegant seating shell in powdercoated stainless steel is upholstered with extra-large, vertical braiding. The braiding material is genuinely innovative: foam mousse is encased in a seamless sheath of knitted textilene and polyolefine which makes the material weather-resistant, but also surprisingly soft to touch. The seating comfort is especially pleasant thanks to the comfortable outdoor cushions.

MATERIALS

- Frame: 304 stainless steel, powdercoated with an ultra durable polyester coating
- Upholstery: braiding with EPDM foam mousse in a knitted sheath of Tricord (polyolefine) and textilene. UV-, rot and mildew resistant. Tested in Xenon tester 2500 hours, QUV tester 2500 hours and 1 year real weather test in Belgium and Singapore
- Seat: Batyline®
- Table top: ceramic.

CUSHIONS

The filling has a cover in a laminated, water-repellent polypropylene material which prevents water from penetrating. The thread used to stitch the seams swells when getting wet, preventing water from penetrating through the seams. Moreover, the seams are protected on the inside with an extra covering. If nevertheless water should penetrate, the material is breathable, letting moisture out to prevent moulding. Fabrics available in category D, E & F.

COLOURS FRAME

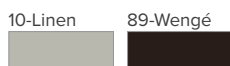

00-White

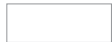

*Only for tables

COLOURS TABLE TOP

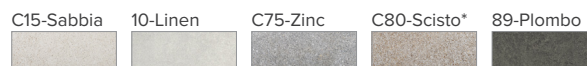

*This colour may possibly show delicate veins.

COLOURS WEAVING

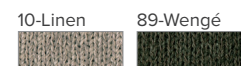

TOSCA

TECHNICAL DRAWINGS

05318-x - Armchair

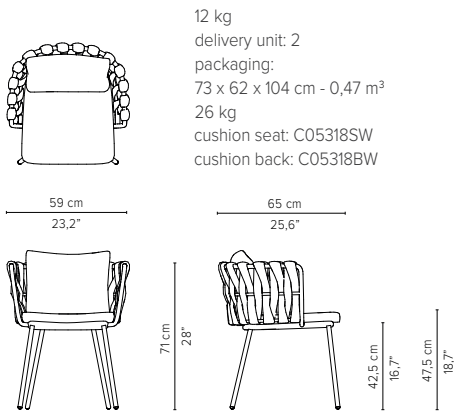

05315-x - Counter Height chair

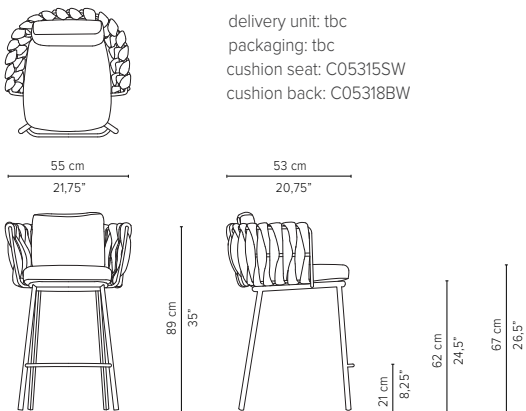

05317-x - Low dining chair

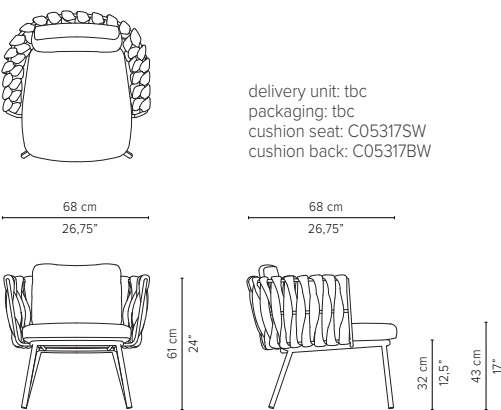

05302-x - Lounge chair

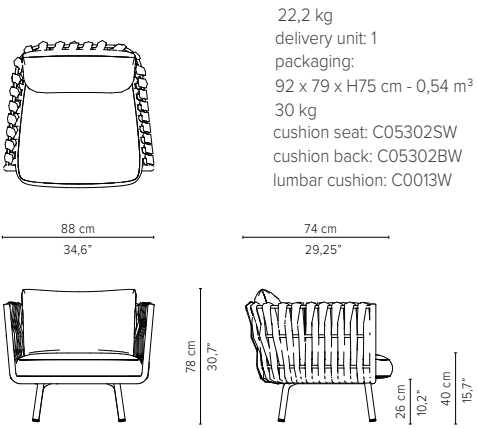

* The cushions on the drawings are not included in the article.
 Appearances, measurements and weights may slightly differ from reality.

TOSCA

TECHNICAL DRAWINGS

05308- x - Sofa 2-seater

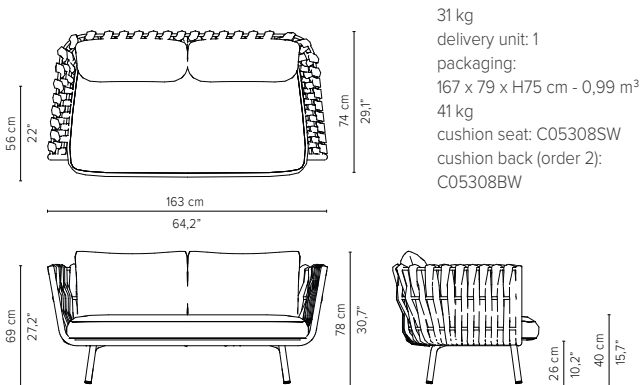

05309- x - Sofa 3-seater

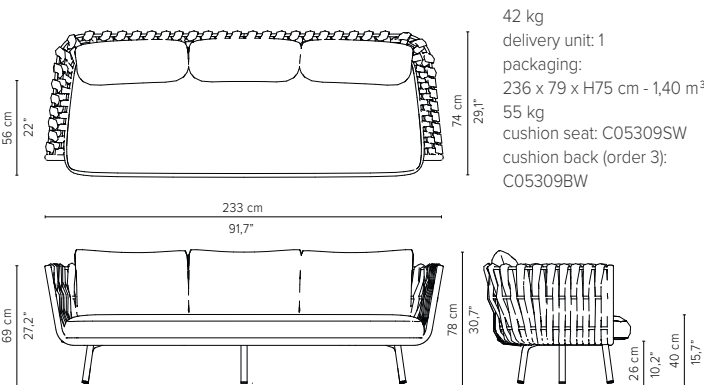

05349- x - Daybed

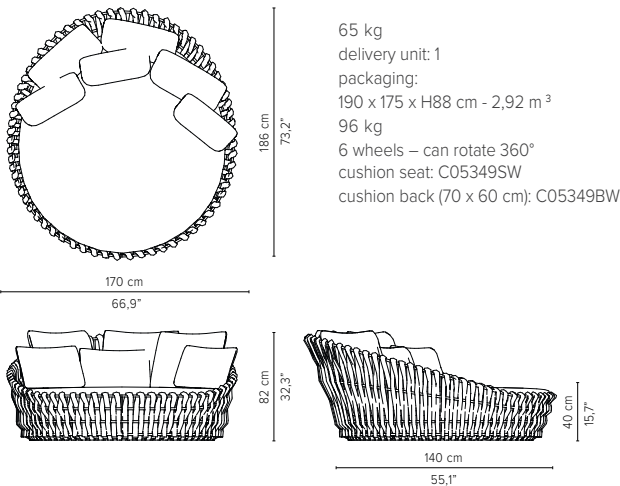

05340- x - Lounger

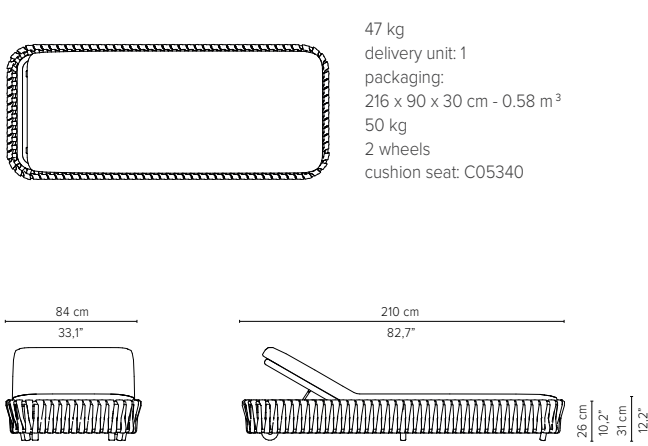

* The cushions on the drawings are not included in the article.
Appearances, measurements and weights may slightly differ from reality.

TOSCA

TECHNICAL DRAWINGS

05355-x - Dining table 240 cm

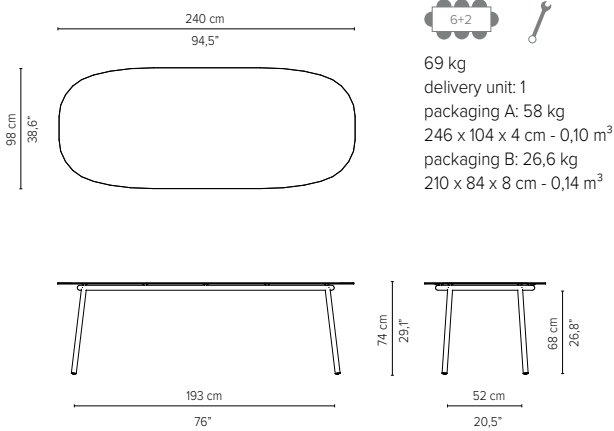

05354-x - Dining table 298 cm

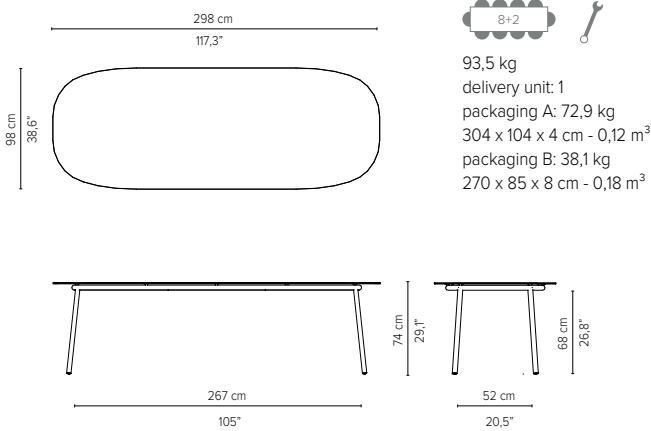

05335-x - Low dining table 240 cm

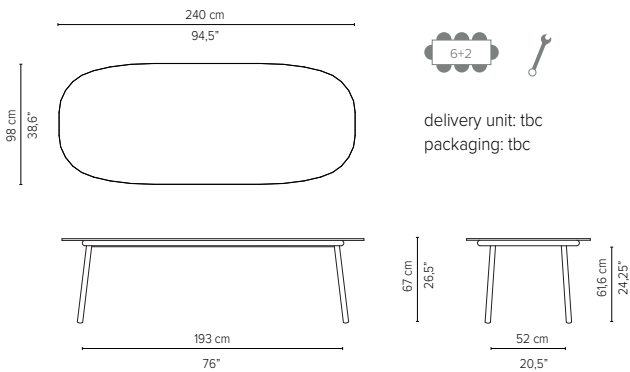

05334-x - Low dining table 298 cm

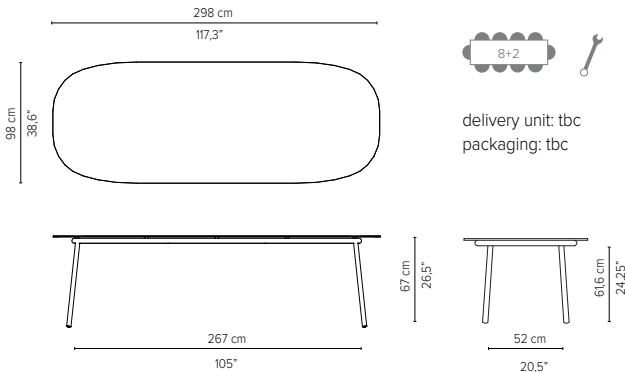

05381-x - Side table

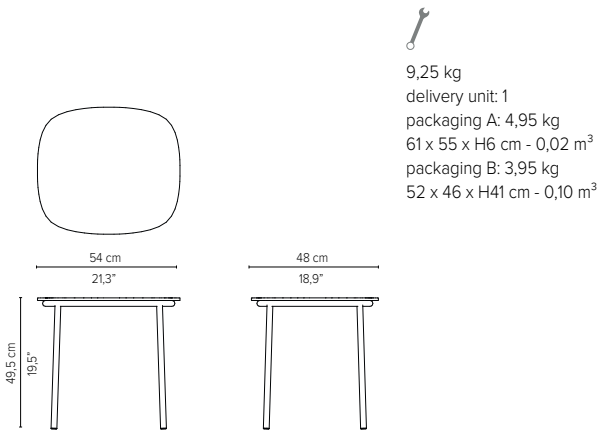

05386-x - Coffee table

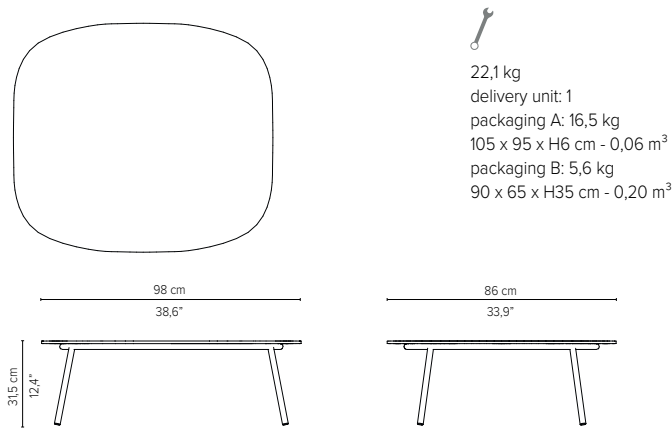

* Appearances, measurements and weights may slightly differ from reality.
x refers to frame, y refers to table top.

PROTECTION COVERS

For each item a cover is available that protects the furniture against dirt. These covers in grey colour are made of PU coated polyester which is water-repellent and UV-resistant. Thanks to their excellent breathable qualities the covers reduce condensation and heat build-up, helping to prevent the formation of mold and mildew. Nevertheless, they are not 100% waterproof. Always make sure that furniture, cushions and covers are completely dry before covering furniture.

MAINTENANCE

Braiding and Frame

Rinse the braiding regularly with clean water. For intensive cleaning, use Synthetics Super Cleaner (D9922). This cleaner also works perfectly for the powdercoated stainless steel frame. Always rinse the furniture with clean water after treatment with Tribù cleaning agents. Allow the braiding to dry and treat with Textile Protector (D9924). This will apply an invisible repellent film which enables the furniture to dry quicker and reduces the adhesion of dirt, stains and pollution. The cleaning will become easier, less frequent and requires mainly rinsing with clean water.



D9922
Synthetics
Super Cleaner



D9924
Textile
Protector

Table top Ceramic

Ceramic is very easy to maintain with clear water and a pH-neutral soap. Stubborn stains can be removed with Glass & Ceramic Cleaner. To protect the ceramic, Ceramic Protector can be used. This applies a highly water and soiling repellent coating, which also makes the surface brighter, smoother and easier to clean.



D9938
Ceramic
Cleaner



D9955
Ceramic
Protector

TECHNICAL STANDARDS

05318 Armchair

ANSI/BIFMA X5.1-2011

EN1022:2005 6
EN581-1:2006 5
EN 1728:2012

ASTM B117-11 (MOD.)

CPSD-HL-01010-MTHD
CPSD-HL-01012-MTHD

AATCC 16
AATCC 106
AATCC 162



05302 Lounge chair

ANSI/BIFMA X5.1-2011

EN1022:2005 6
EN581-1:2006 5
EN 1728:2012

ASTM B117-11 (MOD.)

CPSD-HL-01010-MTHD
CPSD-HL-01012-MTHD

AATCC 16
AATCC 106
AATCC 162



TOSCA

PROJECT REFERENCES



Ritz-Carlton Moscow, Russia – Tosca armchair and Branch contract table in linen



Villa Geba, Montenegro – Tosca loungers and sofa with Branch coffee tables

TOSCA

PROJECT REFERENCES



The Hiramatsu Hotels & Resorts Okinawa, Japan – Tosca sofa's, lounge chairs and coffee tables in linen



Spa @ Hotel Mooshof, Germany – Tosca loungers and daybeds in linen