

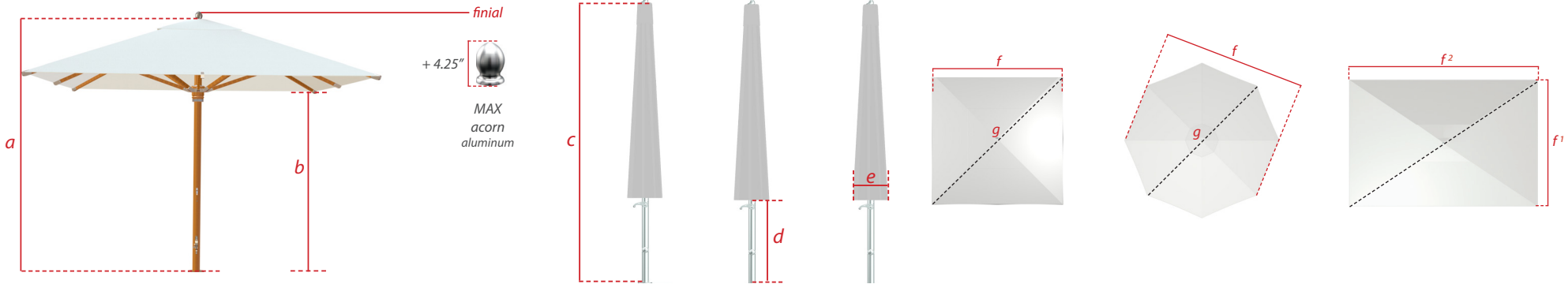

Nautical Teak Hardwood

"auto-loc-lift" marine pulley lift





			mast height (open position)	canopy clearance	mast height (closed position)	table clearance	closed parasol width	flat to flat (Open Umbrella)	point to point	canopy area coverage
	sizes [ft/m]	Pole Diameter	a (in/cm)	b (in/cm)	c (in/cm)	d (in/cm)	e (in/cm)	f (in/cm)	g (in/cm)	ft ²
<i>classic</i>										
<i>square</i>	6.5' / m	2 3/8"	101 / 257	83 / 211	101 / 257	44 / 112	15 / 38	79 / 201	112 / 284	43
	8.0' / 2.45m	2 3/8"	101 / 257	83 / 211	101 / 257	31 / 79	15 / 38	98 / 249	139 / 353	67
<i>octagon</i>	9.0' / 2.75m	2 3/8"	101 / 257	83 / 211	101 / 257	44 / 112	18 / 46	103 / 262	111 / 282	58
	11.5' / m	2 3/8"	101 / 257	79 / 201	101 / 257	31 / 79	18 / 46	125 / 318	136 / 345	91

Nautical Teak Hardwood

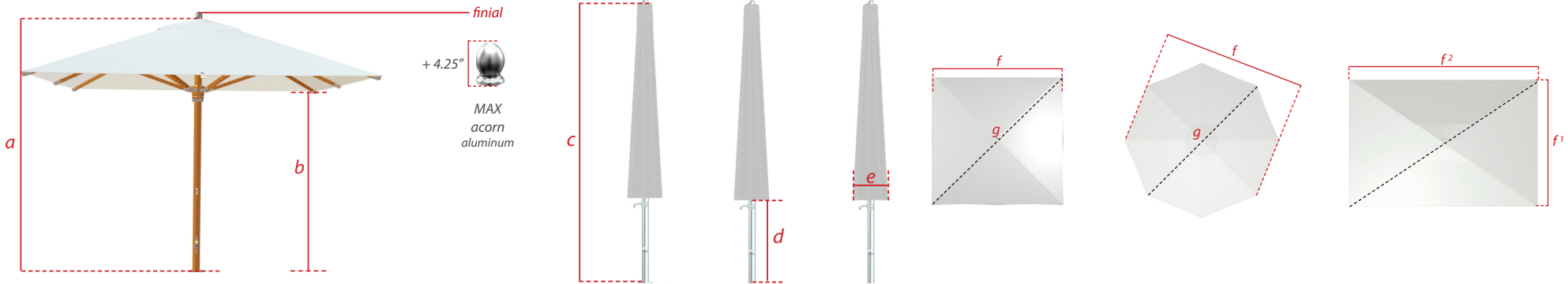
“easy drive” crank



			mast height (open position)	canopy clearance	mast height (closed position)	table clearance	closed parasol width	flat to flat (Open Umbrella)	point to point	canopy area coverage
<i>classic</i>	sizes [ft/m]	Pole Diameter	a (in/cm)	b (in/cm)	c (in/cm)	d (in/cm)	e (in/cm)	f (in/cm)	g (in/cm)	ft ²
<i>square</i>										
	10.0' / 3.0m	3"	110 / 279	90 / 229	137 / 348	47 / 119	15 / 38	120 / 305	170 / 432	100
<i>octagon</i>										
	13.0' / 4.0m	3"	110 / 279	87 / 221	131 / 333	46 / 117	18 / 46	156 / 396	169 / 429	139
<i>rectangle</i>										
	8.0' x 12.0' 2.45m x 3.65m	3"	110 / 279	88 / 224	132 / 335	47 / 119	15 / 38	96X139/ 244X353	169 / 429	93

