



Design Giuseppe Bavuso

## Graphis plus

Inspired by the utmost aesthetic essentiality, the Graphis plus doors are composed of panels in lacquered glass, gres or synthetic leather, surrounded by a structural aluminium profile of minimum thickness. Always custom made, the doors have a recessed metal handle with an insert in the same finish as the panel.

Ispirate alla massima essenzialità estetica, le ante Graphis plus sono composte da pannelli in vetro laccato, grès o similpelle, conclusi da un profilo strutturale in alluminio di minimo spessore. Sempre su misura, le ante sono dotate di maniglia incassata in metallo con inserto nella stessa finitura del pannello.

Inspiriert von höchster ästhetischer Essenz bestehen die Graphis Plus Paneele aus lackiertem Glas, Grès oder Kunstleder, ergänzt durch ein Strukturprofil aus Aluminium mit einer minimalen Stärke. Die Türen werden immer nach Maß gefertigt und haben einen versenkten Metallgriff mit einem Einsatz in der gleichen Ausführung wie das Paneel.

Inspirées par la plus grande essentialité esthétique, les portes Graphis plus sont composées de panneaux en verre laqué, grès ou similcuir complétées par un profil structurel en aluminium d'épaisseur minimale. Toujours sur mesure les portes ont une poignée encastrée métallique avec insert dans la même finition que le panneau.

Inspiradas en la máxima esencialidad estética, los sistemas Graphis plus están compuestos de paneles en vidrio lacado, gris o simil cuero, concluidos con un perfil estructural en aluminio de espesor mínimo. Siempre hechas a medida, las puertas tienen una manilla de metal empotrada con un inserto en el mismo acabado que el panel.

## Caratteristiche tecniche esclusive Exclusive technicals features

Graphis plus

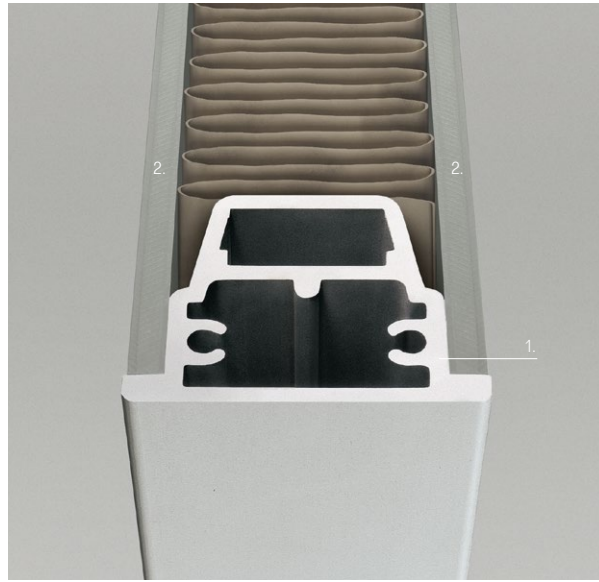

1. Telaio in estruso d'alluminio (lega EN AW-6060 stato fisico T6). Ossidazione anodica conforme alle norme EN 12373, UNI EN ISO 2360. Frame in extruded aluminium (alloy EN AW-6060 physic state T6). Anodic oxidation according to EN 12373, UNI EN ISO 2360 rules.
2. Doppio vetro temperato 4+4 mm in versione laccato, satinato e riflettente. Conformi alle norme UNI EN 12150,

UNI 7697 e UNI EN 12600 in materia di sicurezza per i vetri d'arredamento. / Double 4+4 mm tempered glass in lacquered, satin-finish, and reflecting versions. In accordance with the UNI EN 12150, UNI 7697 and UNI EN 12600 rules with reference to the security of glasses for decoration purposes.

## Descrizione tecnica Technical description

I pannelli scorrevoli Graphis plus vengono sempre realizzati su misura in altezza e larghezza, fino alle dimensioni massime indicate nello schema a fianco.

Graphis plus panels are always customized both in height and width up to the largest sizes specified in the side diagram.

Die Paneele Graphis Plus werden immer nach Maß, sowohl in der Höhe als auch in der Breite, gearbeitet.

Les panneaux coulissants Graphis plus sont toujours réalisés sur mesure en hauteur et largeur, jusqu'aux dimensions maximales indiquées sur le schéma à côté.

Los paneles correderos Graphis plus se realizan siempre a medida tanto en altura como en anchura, hasta las dimensiones máximas indicadas en el esquema de al lado.

## Dimensioni e maniglie Dimensions and handles

Dimensioni pannelli scorrevoli  
Sliding panel dimensions

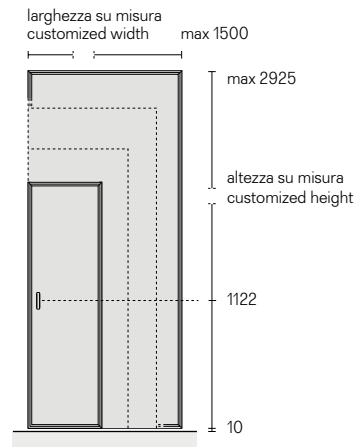

Maniglie Graphis plus  
Handles Graphis plus



1. 2163 maniglia. 2163 handle.
2. 2163N maniglia con nottolino. / 2163N handle with revolving plug. 2163C maniglia con chiave (per porte scorrevoli a scomparsa). / 2163C handle with key (for sliding door into the wall).
3. 9316 maniglia con serratura brevettata e chiave (per porte scorrevoli lineari). 9316 handle with patented lock and key (for linear sliding door).



**Finiture**  
**Finishings**

Struttura  
Structure



Maniglia  
Handle



Pannello  
Panel

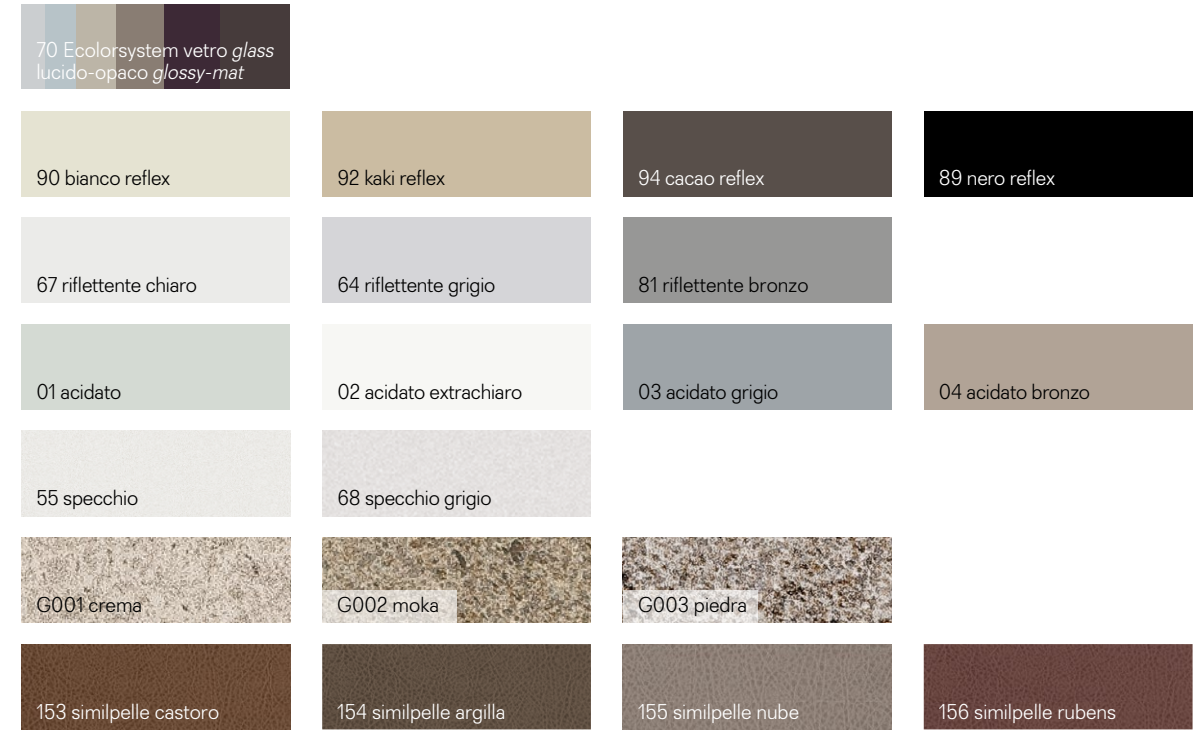

**Binari di scorrimento brevettati**  
Patented sliding rails

**Binario a soffitto**  
Ceiling rail

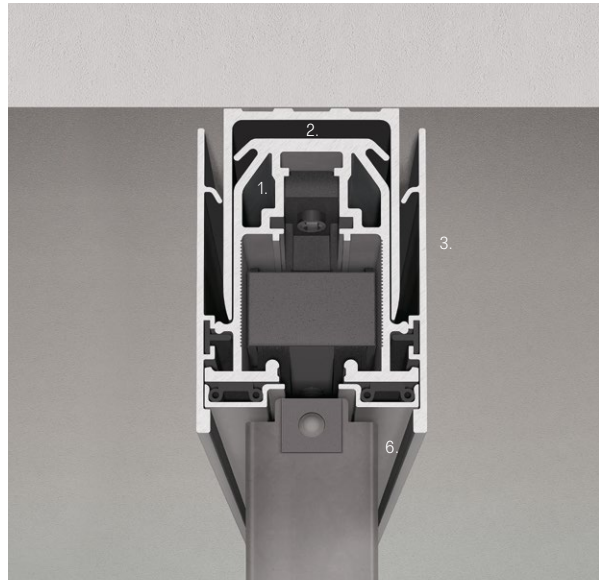

**Monorotaia**  
Single rail

**Birotaia**  
Double rail

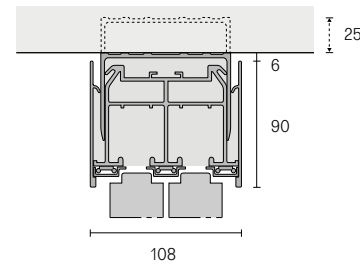
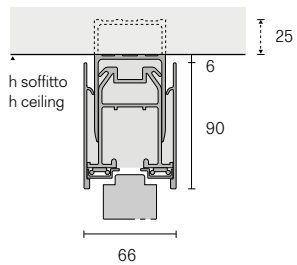

**Trirotaia**  
Three ways rail

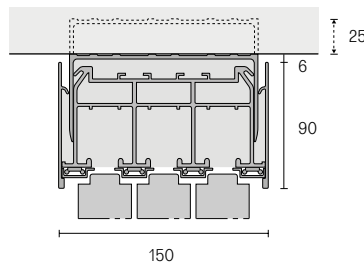

**Quadrirotaia**  
Four ways rail

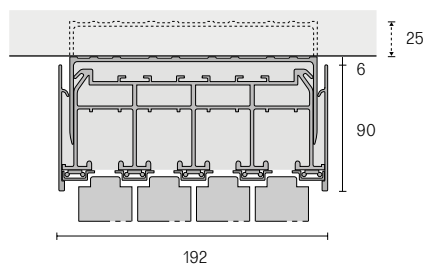

**Binario ad incasso**  
Built-in rail

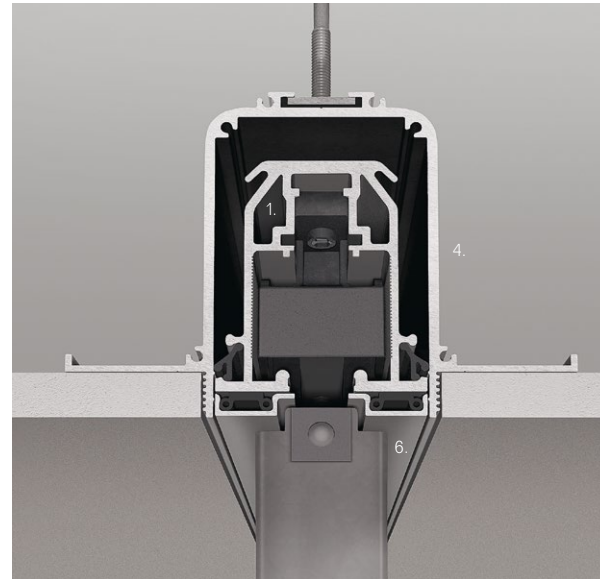

**Monorotaia**  
Single rail

**Birotaia**  
Double rail

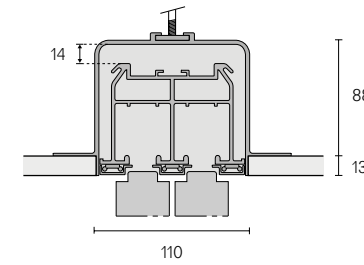
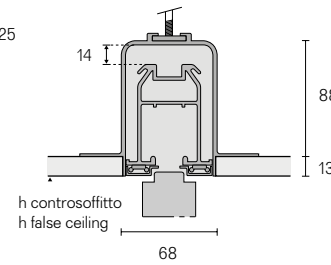

**Trirotaia**  
Three ways rail

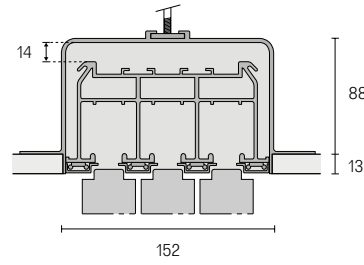

**Quadrirotaia**  
Four ways rail

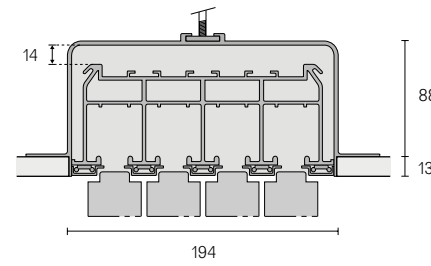

**Binario a parete**  
Wall rail

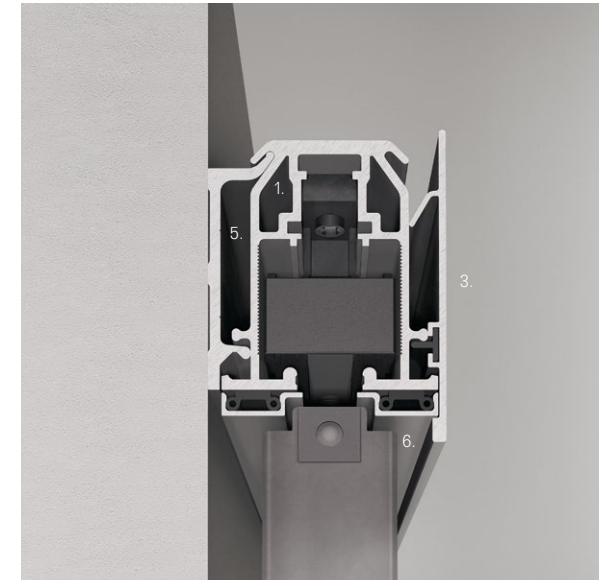

**Monorotaia**  
Single rail

**Birotaia**  
Double rail

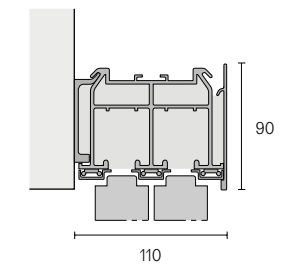
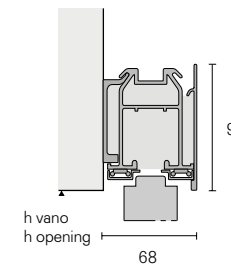

1. Profilo di scorrimento brevettato in estruso d'alluminio. Dimensioni in lunghezza fino a 6000 mm.
2. Profilo telescopico di aggiustaggio brevettato. Consente la perfetta messa in bolla del binario di scorrimento e di compensare gli eventuali dislivelli del soffitto, senza fasce di tamponamento e spessori aggiuntivi.
3. Velella copri-binario in estruso di alluminio. Montaggio rapido ad incasso.
4. Profilo in alluminio ad incasso totale. Binario di scorrimento dotato di regolazione in altezza di 14 mm.
5. Profilo di ancoraggio a parete in lega di alluminio (EN AW-6005A) temperato. Garantito per carichi di 100 kg per metro lineare.
6. Profilo di copertura brevettato in alluminio ad ancoraggio rapido, in tinta alla struttura della porta scorrevole o predisposto per la verniciatura in loco in tinta al soffitto.

1. Profil de coulissement breveté en extrudé d'aluminium. Dimensions exceptionnelles en longueur jusqu'à 6000 mm.
2. Profil télescopique d'ajustage. Il permet de compenser les éventuels défauts du plafond, sans l'utilisation d'aucun type de tamponnement.
3. Bandeau de fermeture en extrudé d'aluminium. Montage à encastrement rapide.
4. Profil en aluminium à encastrement complètement. Rail de coulissement réglable en hauteur de 14 mm.
5. Profil de fixation mural en alliage d'aluminium trempé (EN AW-6005A). Garanti pour poids de 100 Kg par mt.lin.
6. Profil de couverture breveté en aluminium avec système de fixation rapide, dans la même finition de la structure du panneau coulissant ou prêt pour la peinture sur place dans la teinte du plafond.

1. Patented sliding profile in extruded aluminium. Exceptional dimensions in length till 6000 mm.
2. Patented telescopic adjusting profile. It allows to counterbalance differences in ceiling height without the use of padding or coverings.
3. Closing cover for rail in extruded aluminium. Quick assembling.
4. Aluminium total built in profile. Rail adjustable for 14 mm.
5. Wall fixing section in hardened aluminium alloy (EN AW-6005A). Guaranteed for loads of 100 kg per linear metre.
6. Patented aluminium covering profile with quick fixing system, in the same color of the sliding panel structure or prepared to be painted on site to match the ceiling.

1. Perfil corredero patentado en extrusión de aluminio. Dimensiones excepcionales hasta 6000 mm.
2. Perfil telescópico de ajuste patentado. Permite ajustar eventuales desniveles del techo, sin bandas y espesores añadidos.
3. Tapa de cierre en extrusión de aluminio. Montaje rápido a encaje.
4. Perfil en aluminio embutido totalmente. Guía dotada de regulación en altura de 14 mm.
5. Perfil de anclaje a pared en aleación de aluminio (EN AW-6005A) templado. Garantizado para cargas de 100 Kg por metro lineare.
6. Perfil embellecedor en aluminio de sujeción rápida patentado, combinado a la estructura del panel corredero o preparado para la pintura en obra combinada al acabado del techo.

1. Patentiertes Laufprofil aus Druckguss Aluminium. Gesamtlänge von 6000 mm lieferbar.
2. Patentierten teleskopischen Profil. Sie erlaubt eine Ausgleichung eventueller Decken-unebenheiten ohne zusätzliche Vorarbeiten.
3. Blende aus gezogenen Aluminiumguss, schnelle Klick-Montage.
4. Eingebauter Aluminium Profil. Laufschiene regulierbar in Höhe von 14 mm.
5. Decke-Befestigungsprofil aus temperierter Aluminium-Legierung (EN AW-6005A). Garantierte Tragfähigkeit 100Kg pro Laufmeter.
6. Patentierte Abdeckprofile aus Aluminium mit System zur schnellen Montage. Erhältlich in der Strukturfarbe der Schiebepaneele oder grundiert, um vor Ort in der Deckenfarbe lackiert zu werden.



## Componenti del binario di scorrimento Sliding rail components

- Binario di scorrimento con profilo telescopico di aggiustaggio brevettato. Consente la perfetta messa in bolla del binario di scorrimento. Regolazione in altezza di 25 mm per la versione a soffitto.
  - Freno soft motion, dotato di molle di richiamo e pistoncino a gas, inseriti in un supporto in nylon fibra stampato ad iniezione.
  - Carrello di scorrimento. Corpo in nylon basculante su due assi, progettato per seguire le eventuali imperfezioni della parete e del soffitto garantendo uno scorrimento sempre perfetto. Ruote in nylon e fibra di vetro. Portata max 100 kg per carrello.
- Rail de coulissement avec profilé télescopique d'ajustage breveté. Il permet de mettre parfaitement à niveau le rail de coulissement. Réglage en hauteur de 25 mm pour la version au plafond.
  - Frein soft motion avec ressorts de retour et petit piston à huile, insérés dans un support en fibre de nylon moulé par injection.
  - Chariot de coulissement. Corps en nylon, basculant sur deux axes, étudié pour suivre les éventuelles imperfections du mur et du plafond en garantissant un coulissement toujours parfait. Roulettes en nylon et fibre de verre. Charge maximale de 100 kg par chariot.
- Guía de deslizamiento con perfil telescópico de ajuste patentado. Permite un perfecto alineamiento de la guía. Regulación de la altura de 25 mm para la versión de techo.
  - Freno soft motion, equipado con resortes de retorno y de pistón al aceite, colocados en un soporte en fibra de nylon, moldeado por inyección.
  - Carro de deslizamiento. Cuerpo de nylon basculante sobre dos ejes, diseñado para seguir las eventuales imperfecciones de la pared y del techo garantizando un deslizamiento siempre perfecto. Ruedas de nylon y fibra de vidrio. Carga útil máx. 100 kg por carro.
- Gleitschiene mit patentiertem Teleskopprofil zur Justierung. Ermöglicht eine perfekte waagerechte Ausrichtung der Gleitschiene. Höhenregulierung um 25 mm für Deckenschiene.
  - Eingebauter Soft-Motion-Bremse, mit der Rückkehr-Federn und Kolben-Öl ausgestattet, die in der spritzgegossenen Unterstüzung von Nylon-Faser, eingebaut sind.
  - Laufwagen Doppelgehäuse aus Nylon, zweiachsig schwingend, geplant, um eventuelle Unebenheiten an Wand und Decke auszugleichen und ein perfektes Gleiten in jeder Situation zu garantieren. Rollen aus Nylon und Glasfaser. Höchstlast pro Laufwagen 100 kg.

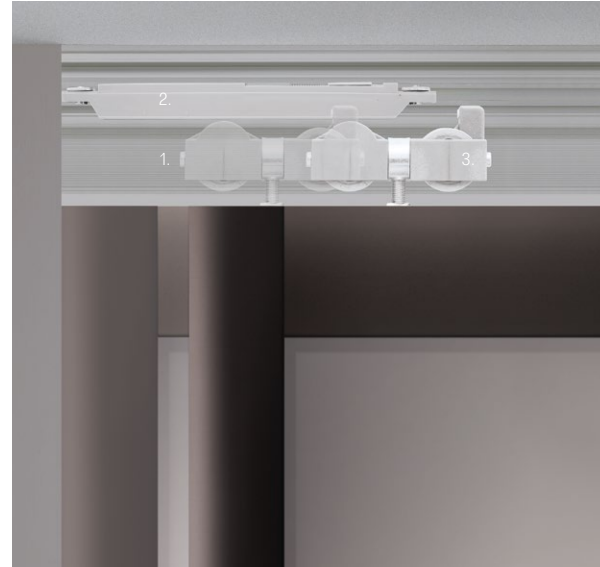

## Binario in tinta con la struttura o predisposto per la verniciatura Rail in the same finishing of the panel structure or ready to be painted on site

- Profilo di scorrimento brevettato con microaletture interne, studiate per ridurre e attutire il rumore durante lo scorrimento del pannello.
  - Regolazione in altezza del pannello mediante giunto cardanico laterale: la regolazione è effettuabile anche con il pannello già montato per semplificare al massimo le operazioni di montaggio.
  - Profili di copertura in alluminio predisposti per la verniciatura in loco in tinta al soffitto.
  - Profili di copertura brevettati in estruso di alluminio ad aggancio rapido, in tinta alla struttura delle porte scorrevoli.
- Patented sliding profile with internal micro finning, designed to reduce and deaden the noise of the panel when it slides.
  - Adjustment in height of the panel thanks to the lateral cardan joint. The adjustment is possible also with the panel already mounted in order to simplify to the maximum the assembly operations.
  - Covering profiles in aluminium prepared to be painted to match the ceiling.
  - Patented covering profiles in extruded aluminium with quick fixing system, in the same finishing of the sliding panels structure.
- Profil de coulissement breveté avec des petites ailettes internes, conçu pour réduire et amortir le bruit lors du coulissement du panneau.
  - Réglage en hauteur du panneau par joint de cardan latéral. Le réglage est également réalisable sur le panneau déjà monté afin de simplifier au maximum les opérations de montage.
  - Profils de finition en aluminium préparé pour être peint sur place dans la même couleur du plafond.
  - Profils de finition en extrusion d'aluminium avec fixation rapide, dans la même couleur de la structure des panneaux coulissants.
- Guía corredera patentada con micro aletas internas, diseñadas para reducir y amortiguar el ruido durante el deslizamiento del panel.
  - Regulación en altura del panel por medio de cardán lateral. El ajuste también es posible con el panel ya montado para simplificar las operaciones de montaje.
  - Perfiles embellecedores en aluminio preparados para ser pintados en obra en el mismo color del techo.
  - Perfiles embellecedores patentados en extrusión de aluminio con enganche rápido, del mismo color que la estructura del panel.
- Patentiertes Laufprofil mit Mikroinnenrippen, die die Gleitgeräusche der Türplatte verringern.
  - Höhenregulierung der Türplatte mittels eines Kardangelenkes. Zur weiteren Vereinfachung der Montage ist die Regulierung auch möglich, wenn die Platte bereits installiert ist.
  - Die vor Ort Lackierung der Aluminiumabdeckungen sind in derselben Farbe der Decke erhältlich.
  - Patentierte Schnellkupplung Aluminiumabdeckungen sind in derselben Farbe der Türplatte erhältlich.



**Pannelli porta abbinati ai binari di scorrimento**  
**Door panels for sliding rails**

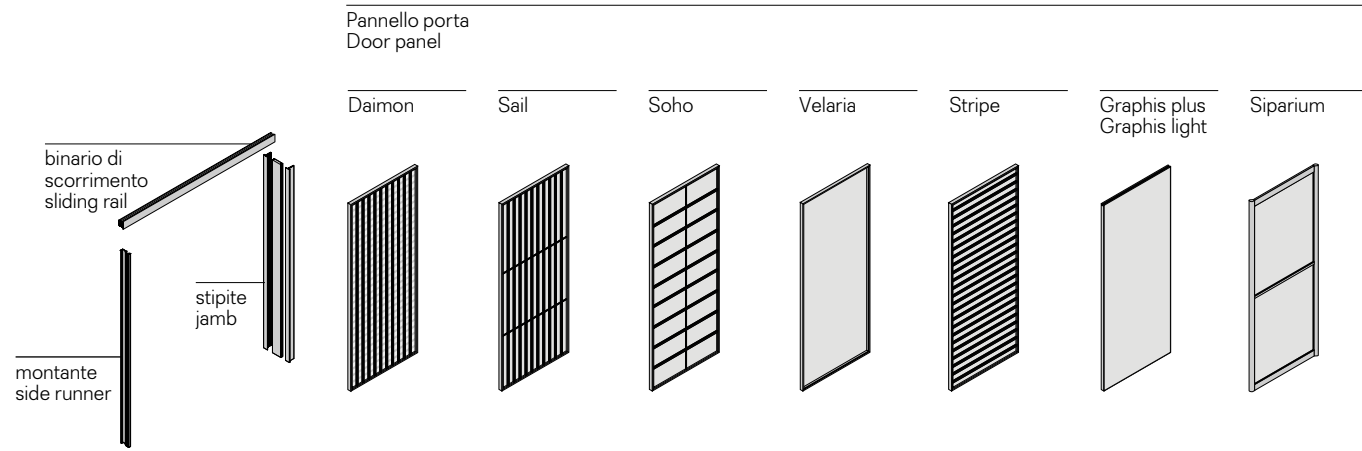

**Descrizione tecnica**  
**Technical description**

Tutte le porte scorrevoli Rimadesio sono state ingegnerizzate per garantire la massima semplicità di progettazione e per essere installate sull'esclusivo sistema di scorrimento a parete, soffitto e incasso. Una porta scorrevole completa è composta da un binario di scorrimento, un pannello porta e uno stipite o montante opzionale. L'apertura a libro e battente è disponibile unicamente per i pannelli Siparium. Il sistema utilizza un binario di scorrimento e carrelli differenti dal modello a scorrimento lineare.

All Rimadesio sliding panels have been engineered to guarantee the highest design simplicity and to be installed on the exclusive wall, ceiling and built-in sliding systems. A complete sliding panel is made up of rail, door panel and optional jamb or side runner. Folding and swing doors are available only for Siparium panels. The system uses a sliding rail and carriages that are different from the linear model.

Alle Schiebetüren von Rimadesio funktionieren mit einer Wand-, Decken- oder Deckeneinbauschiene. Eine komplette Schiebetüranlage besteht aus einer Schiene, einem Türpanel und einem optionalen Türpfosten. Die Klapptür ist lediglich für die Siparium-Paneele verfügbar. Das System verwendet eine Gleitschiene und einen Schieber, wodurch sie sich vom linearen Gleitmodell unterscheidet.

Tous les panneaux coulissants Rimadesio ont été conçus pour un maximum de simplicité dans le projet et pour être installé sur l'exclusif système de rail plafond, mural ou encastré. Un panneau coulissant complet est composé par un rail, un panneau et un jambage ou montant en option. L'ouverture des portes pliantes et battantes est disponible uniquement pour les panneaux Siparium. Le système utilise un rail et des chariots différents du modèle coulissant linéaire.

Todas las puertas correderas Rimadesio han sido diseñadas para garantizar la máxima simplicidad del diseño y ser instaladas en el exclusivo sistema de deslizamiento a pared, a techo y embutido. Una puerta corredera completa se compone de un carril de deslizamiento, un panel de puertay una jamba o montante opcional. La apertura plegable batiente está disponible solo para los paneles Siparium. El sistema usa una guía y carros diferentes del los del cierre lineal.

**Calcolo altezze pannelli porta**  
**Heights calculation panels**

Binario a soffitto  
 Ceiling rail

Velaria, Soho, Stripe, Sail, Daimon  
 $H_{\text{pannello panel}} = H_{\text{soffitto minima}} - 97 \text{ mm}$

Graphis plus, Graphis light, Siparium  
 $H_{\text{pannello panel}} = H_{\text{soffitto minima}} - 104 \text{ mm}$

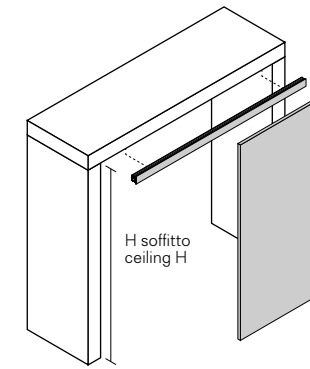

Binario ad incasso  
 Built in rail

Velaria, Soho, Stripe, Sail, Daimon  
 $H_{\text{pannello panel}} = H_{\text{controsoffitto minima}} - 8 \text{ mm}$

Graphis plus, Graphis light, Siparium  
 $H_{\text{pannello panel}} = H_{\text{controsoffitto minima}} - 15 \text{ mm}$

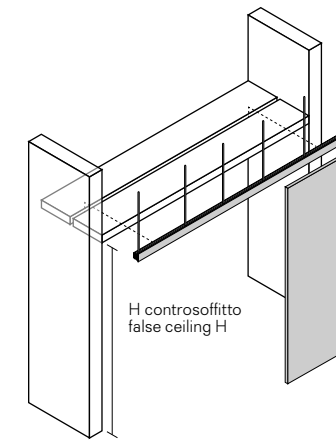

Binario a parete  
 Wall rail

Velaria, Soho, Stripe, Sail, Daimon  
 $H_{\text{pannello panel}} = H_{\text{vano massima}} + 4 \text{ mm}$

Graphis plus, Graphis light, Siparium  
 $H_{\text{pannello panel}} = H_{\text{vano massima}} - 3 \text{ mm}$

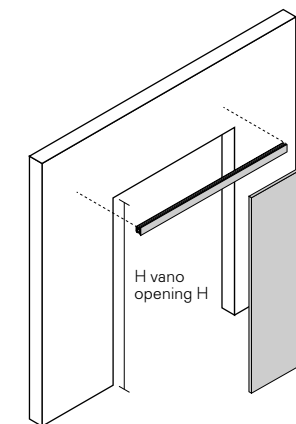



**Calcolo larghezze pannelli porta**  
**Widths calculation panels**

**Monorotaia fuori luce**  
**Single rail out of the opening**

Con montante laterale  
 With side runner

- |  |  |
|--|--|
| Velaria, Stripe, Sail, Soho, Daimon<br>A = 13 mm<br>B = 12 mm<br>L = L vano opening W - 1 mm | Graphis light<br>A = 13 mm<br>B = 20 mm<br>L = L vano opening W + 7 mm |
| Graphis plus<br>A = 13 mm<br>B = 15 mm<br>L = L vano opening W + 2 mm                        | Siparium<br>A = 15 mm<br>B = 25 mm<br>L = L vano opening W + 10 mm     |

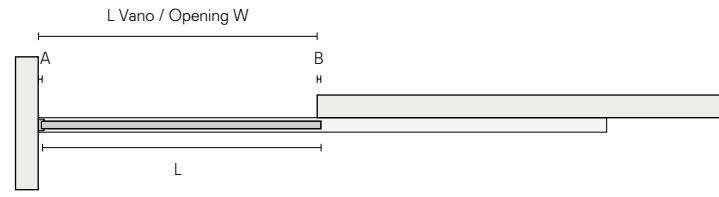

Senza montanti laterali  
 Without side runners

- |  |  |
|--|--|
| Velaria, Stripe, Sail, Soho, Daimon<br>A = 12 mm<br>L = L vano W opening + 24 mm | Graphis light<br>A = 20 mm<br>L = L vano W opening + 40 mm |
| Graphis plus<br>A = 15 mm<br>L = L vano W opening + 30 mm                        | Siparium<br>A = 25 mm<br>L = L vano W opening + 50 mm      |

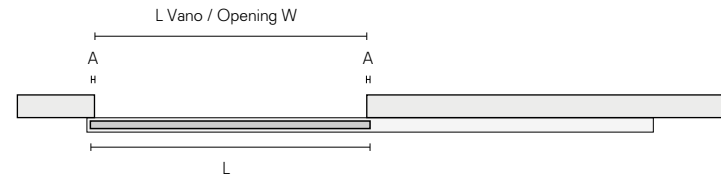

- |  |  |
|--|--|
| Velaria, Stripe, Sail, Soho, Daimon<br>A = 12 mm<br>B = 2 mm<br>L = (L vano opening W + 22 mm) ÷ 2 | Graphis light<br>A = 20 mm<br>B = 0 mm<br>L = (L vano opening W + 40 mm) ÷ 2 |
| Graphis plus<br>A = 15 mm<br>B = 0 mm<br>L = (L vano opening W + 30 mm) ÷ 2                        | Siparium<br>A = 25 mm<br>B = 0 mm<br>L = (L vano opening W + 50 mm) ÷ 2      |

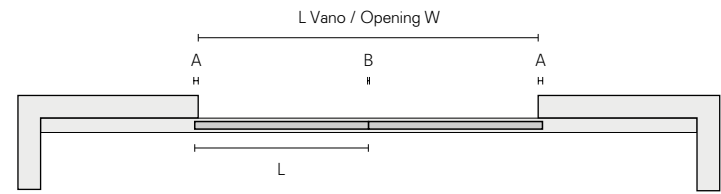

**Birotaia fuori luce**  
**Double rail out of the opening**

Senza montanti laterali  
 Without side runners

- |   |  |
|---|--|
| Velaria, Stripe, Sail, Soho, Daimon<br>A = 12 mm<br>B = 12 mm<br>C = 1 mm<br>L = (L vano opening W + 23 mm) ÷ 2 | Graphis light<br>non disponibile / not available                                     |
| Graphis plus<br>A = 15 mm<br>B = 30 mm<br>C = 0 mm<br>L = (L vano opening W + 45 mm) ÷ 2                        | Siparium<br>A = 25 mm<br>B = 50 mm<br>C = 0 mm<br>L = (L vano opening W + 75 mm) ÷ 2 |

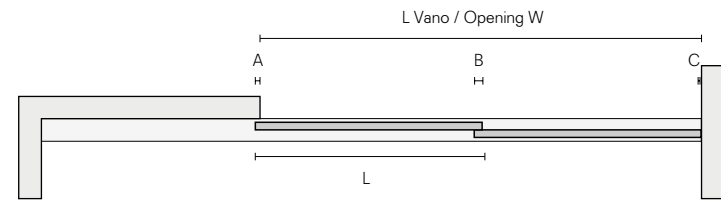

- |   |   |
|---|---|
| Velaria, Stripe, Sail, Soho, Daimon<br>A = 12 mm<br>B = 12 mm<br>C = 2 mm<br>L = (L vano opening W + 46 mm) ÷ 4 | Graphis light<br>non disponibile / not available                          |
| Graphis plus<br>A = 30 mm<br>B = 15 mm<br>L = (L vano opening W + 90 mm) ÷ 4                                    | Siparium<br>A = 50 mm<br>B = 25 mm<br>L = (L vano opening W + 150 mm) ÷ 4 |

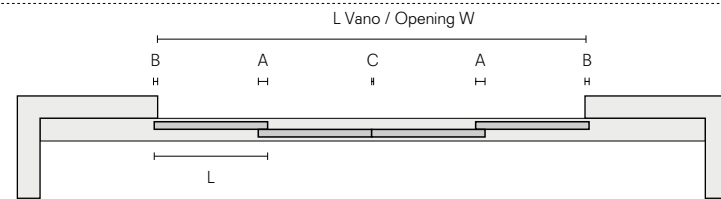

**Birotaia in luce**  
**Double rail in the opening**

Con montanti laterali  
 With side runners

- |   |   |
|---|---|
| Velaria, Stripe, Sail, Soho, Daimon<br>A = 13 mm<br>B = 12 mm<br>L = (L vano opening W - 14 mm) ÷ 2 | Graphis light<br>A = 13 mm<br>B = 13 mm<br>L = (L vano W opening - 13 mm) ÷ 2 |
| Graphis plus<br>A = 13 mm<br>B = 30 mm<br>L = (L vano opening W + 4 mm) ÷ 2                         | Siparium<br>A = 15 mm<br>B = 50 mm<br>L = (L vano opening W + 20 mm) ÷ 2      |

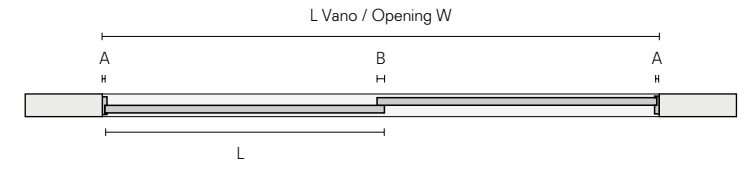

- |  |  |
|--|--|
| Velaria, Stripe, Sail, Soho, Daimon<br>A = 13 mm<br>B = 12 mm<br>L = (L vano opening W - 2 mm) ÷ 3 | Graphis light<br>A = 13 mm<br>B = 13 mm<br>L = L vano opening W ÷ 3      |
| Graphis plus<br>A = 13 mm<br>B = 30 mm<br>L = (L vano opening W + 34 mm) ÷ 3                       | Siparium<br>A = 15 mm<br>B = 50 mm<br>L = (L vano opening W + 70 mm) ÷ 3 |

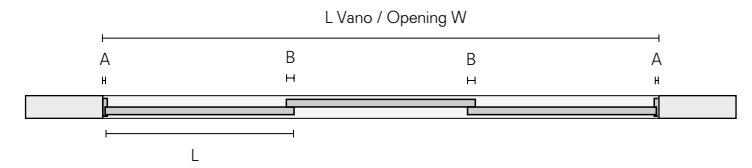

Senza montanti laterali  
 Without side runners

- |  |  |
|--|--|
| Velaria, Stripe, Sail, Soho, Daimon<br>A = 1 mm<br>B = 12 mm<br>L = (L vano opening W + 10 mm) ÷ 2 | Graphis light<br>A = 0 mm<br>B = 13 mm<br>L = (L vano opening W + 13 mm) ÷ 2 |
| Graphis plus<br>A = 0 mm<br>B = 30 mm<br>L = (L vano opening W + 30 mm) ÷ 2                        | Siparium<br>A = 0 mm<br>B = 50 mm<br>L = (L vano opening W + 50 mm) ÷ 2      |

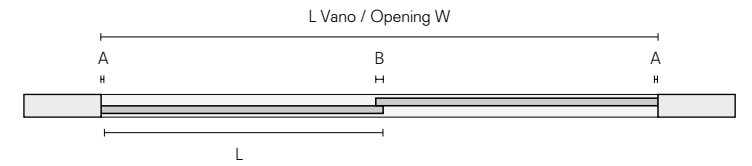

- |  |  |
|--|--|
| Velaria, Stripe, Sail, Soho, Daimon<br>A = 12 mm<br>B = 1 mm<br>C = 2 mm<br>L = (L vano opening W + 20 mm) ÷ 4 | Graphis light<br>A = 13 mm<br>L = (L vano opening W + 26 mm) ÷ 4 |
| Graphis plus<br>A = 30 mm<br>L = (L vano opening W + 60 mm) ÷ 4  | Siparium<br>A = 50 mm<br>L = (L vano opening W + 100 mm) ÷ 4     |

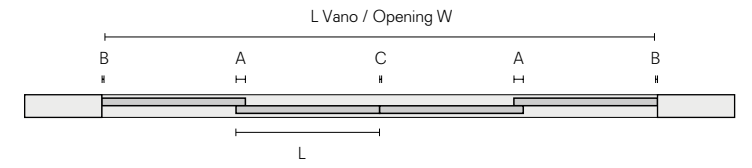

**Calcolo larghezze pannelli porta**  
Widths calculation panels

**Trirotaia in luce**  
Three ways rail in the opening

Con montanti laterali  
With side runners

Velaria, Stripe, Sail, Soho, Daimon  
A = 12 mm  
B = 13 mm  
L = (L vano opening W - 2 mm) ÷ 3

Graphis light  
non disponibile / not available

Graphis plus  
A = 30 mm  
B = 13 mm  
L = (L vano opening W + 34 mm) ÷ 3

Siparium  
A = 50 mm  
B = 15 mm  
L = (L vano opening W + 70 mm) ÷ 3

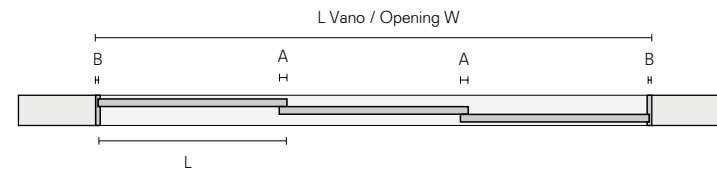

Senza montanti laterali  
Without side runners

Velaria, Stripe, Sail, Soho, Daimon  
A = 12 mm  
B = 1 mm  
C = 2 mm  
L = (L vano opening W + 44 mm) ÷ 6

Graphis light  
non disponibile / not available

Graphis plus  
A = 30 mm  
L = (L vano opening W + 120 mm) ÷ 6

Siparium  
A = 50 mm  
L = (L vano opening W + 200 mm) ÷ 6

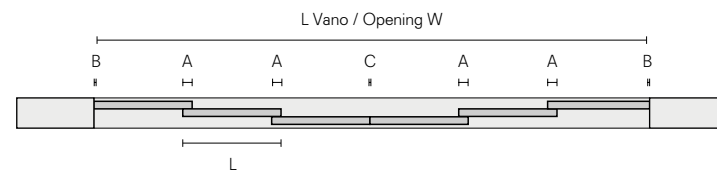

**Quadrirotaia in luce**  
4 ways rail in the opening

Senza montanti laterali  
Without side runners

Velaria, Stripe, Sail, Soho, Daimon  
A = 12 mm  
B = 1 mm  
L = (L vano opening W + 34 mm) ÷ 4

Graphis light  
non disponibile / not available

Graphis plus  
A = 30 mm  
L = (L vano opening W + 90 mm) ÷ 4

Siparium  
A = 50 mm  
L = (L vano opening W + 150 mm) ÷ 4

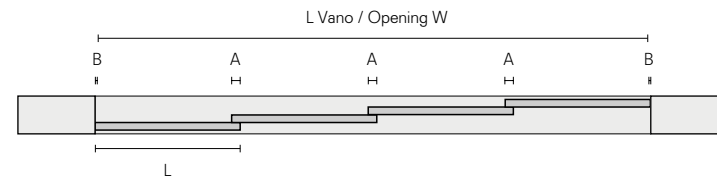

**Sormonto dei pannelli**  
Panels overlapping

**Monorotaia fuori luce**  
Single rail out of the opening

Senza montanti laterali  
Without side runners

Velaria, Stripe, Sail, Soho, Daimon  
A = 12 mm  
B = 1 mm  
C = 32 mm  
C1 = maniglia handle 2093C = 77 mm

Graphis light  
A = 20 mm  
B = 0 mm  
C = 39 mm

Graphis plus  
A = 15 mm  
B = 0 mm  
C = 10 mm  
C1 = maniglia handle 2163C = 89 mm

Siparium  
A = C = 25 mm  
B = 0 mm

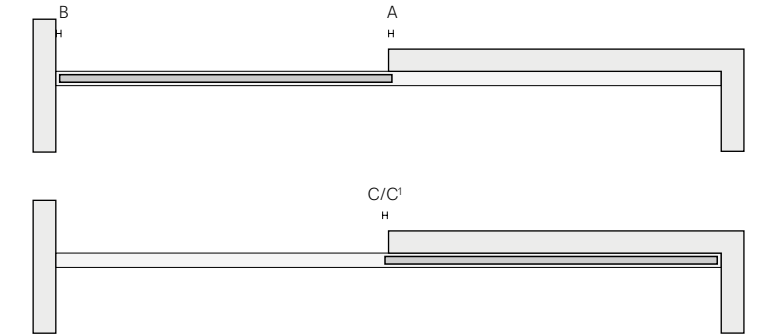

**Birotiaia fuori luce**  
Double rail out of the opening

Senza montanti laterali  
Without side runners

Velaria, Stripe, Sail, Soho, Daimon  
A = 12 mm  
B = 12 mm  
C = 1 mm  
D = E = 32 mm  
E1 = maniglia handle 2093C = 77 mm

Graphis light  
non disponibile / not available

Graphis plus  
A = 30 mm  
B = 15 mm  
C = E = 0 mm  
D = 10 mm  
E1 = maniglia handle 2163C = 76 mm

Siparium  
A = 50 mm  
B = D = 25 mm  
C = 0 mm  
E = 15 mm  
E1 = 78 mm

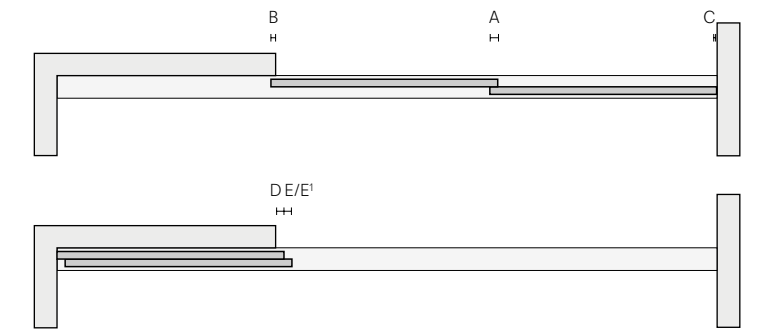

**Birotiaia in luce**  
Double rail in the opening

Senza montanti laterali  
Without side runners

Velaria, Stripe, Sail, Soho, Daimon  
A = 12 mm  
B = 1 mm  
C = 2 mm  
D = 32 mm  
D1 = maniglia handle 2093C = 77 mm

Graphis light  
A = 13 mm  
B = C = 0 mm  
D = 46 mm

Graphis plus  
A = 30 mm  
B = C = D = 0 mm  
D1 = maniglia handle 2163C = 76 mm

Siparium  
A = 50 mm  
B = C = 0 mm  
D = 15 mm  
D1 = maniglia handle 773 = 78 mm

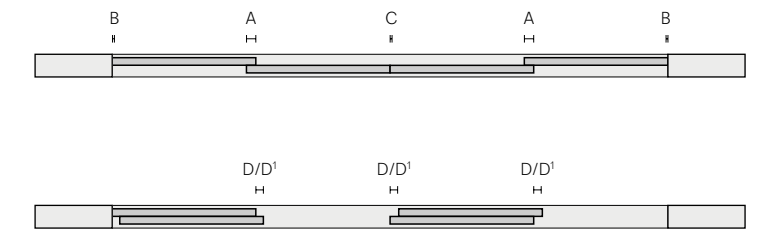

**Trirotaia in luce**  
Three ways in the opening

Con montanti laterali  
With side runners

Velaria, Stripe, Sail, Soho, Daimon  
A = 12 mm  
B = 13 mm  
C = 22 mm  
D = 48 mm  
E = 32 mm  
E1 = maniglia handle 2093C = 77 mm

Graphis light  
non disponibile / not available

Graphis plus  
A = 30 mm  
B = 13 mm  
C = 22 mm  
D = 8 mm  
E = 0 mm  
E1 = maniglia handle 2163C = 76 mm

Siparium  
A = 50 mm  
B = D = E = 15 mm  
C = 30 mm  
E1 = maniglia handle 773 = 78 mm

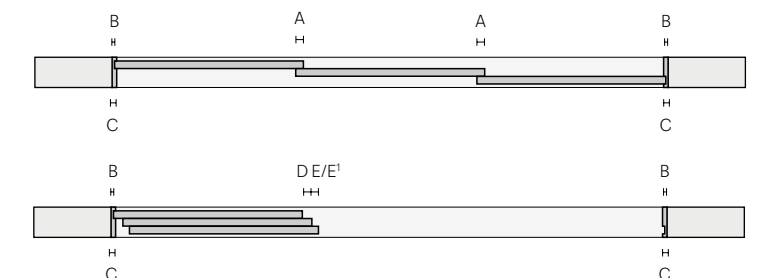

Sliding doors

Types of sliding rail installations



Composizioni ad angolo retto con binari a soffitto e ad incasso  
 90° corner compositions with ceiling and built-in rails

Monorotaia in luce  
 Single rail in the opening

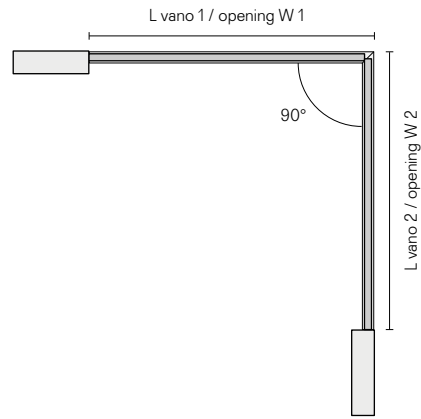

Monorotaia fuori luce  
 Single rail out of the opening

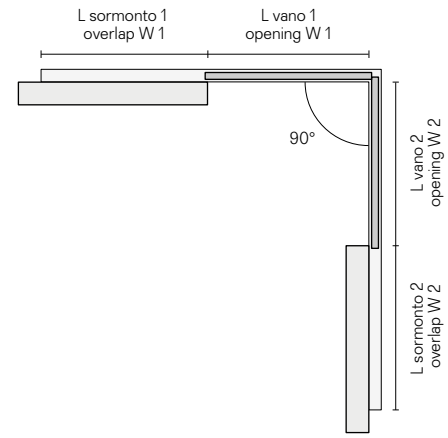

Monorotaia e birotaia in luce  
 Single and double rail in the opening

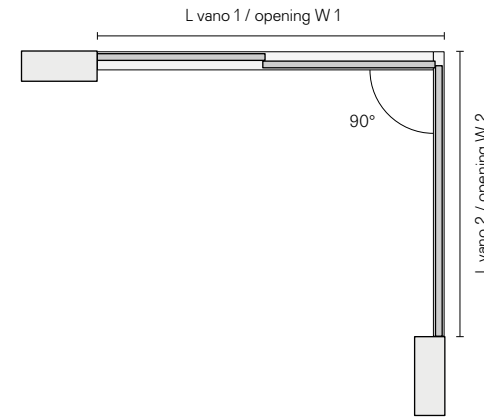

Monorotaia e birotaia fuori luce  
 Single and double rail out of the opening

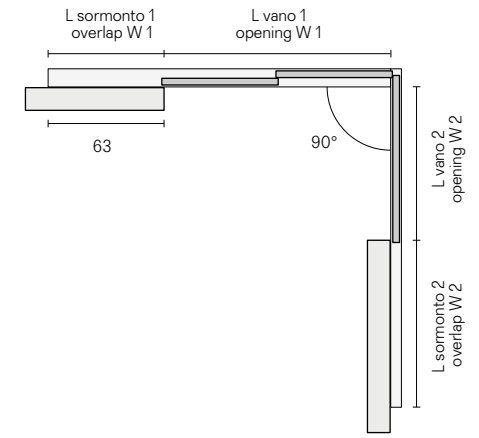

Birotaia in luce  
 Double rail in the opening

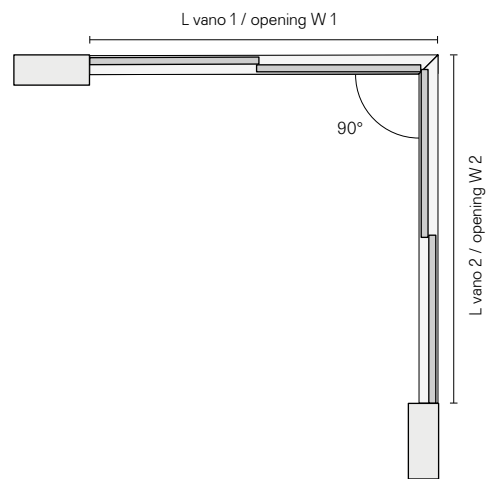

Birotaia fuori luce  
 Double rail out of the opening

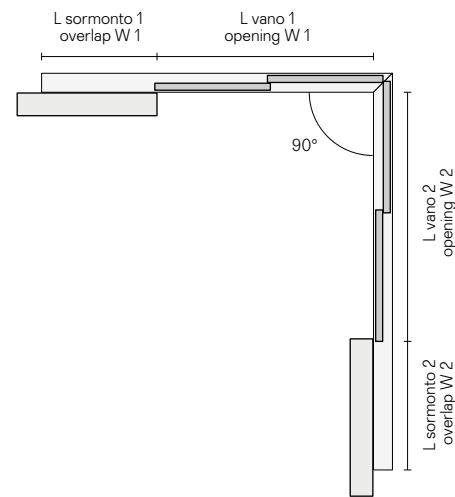

Birotaia e trirotaia in luce  
 Double and 3 ways rail in the opening

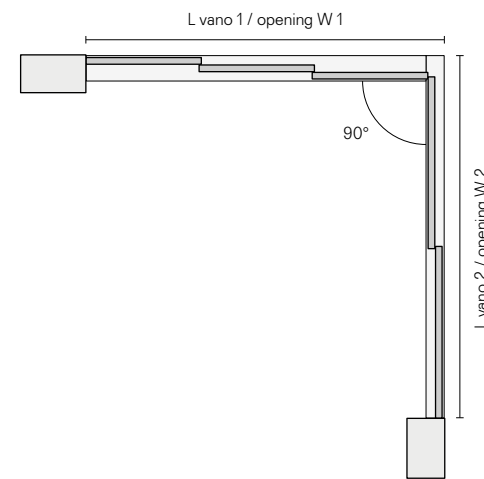

Birotaia e trirotaia fuori luce  
 Double and 3 ways rail out of the opening

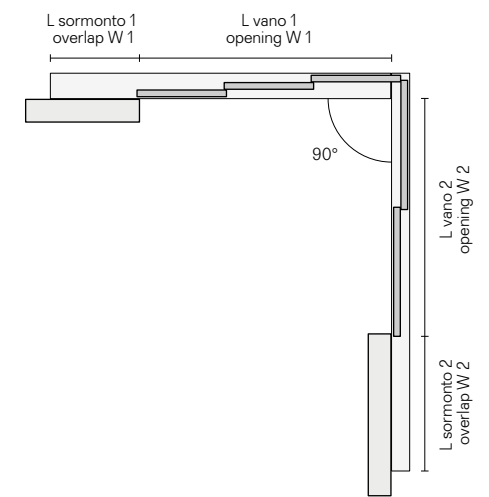

Trirotaia in luce  
 Three ways rail in the opening

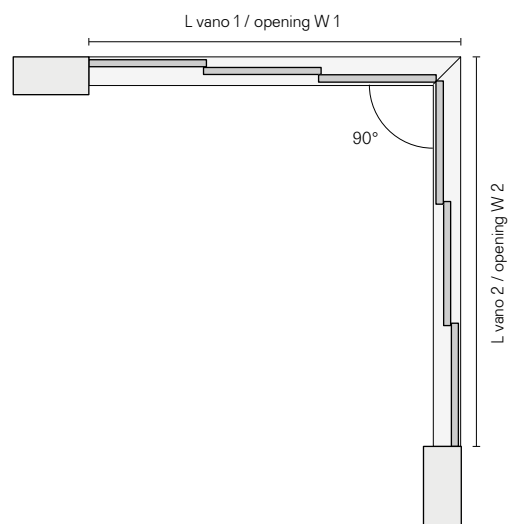

Trirotaia fuori luce  
 Three ways rail out the opening

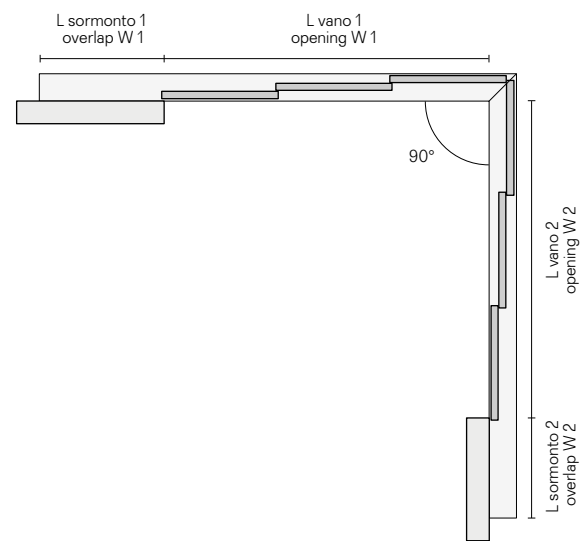

Birotaia e quadrirotaia in luce  
 Double and 4 ways rail in the opening

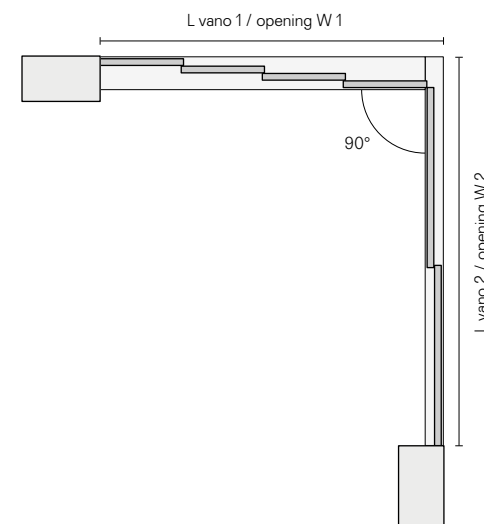

Birotaia e quadrirotaia fuori luce  
 Double and 4 ways rail out of the opening

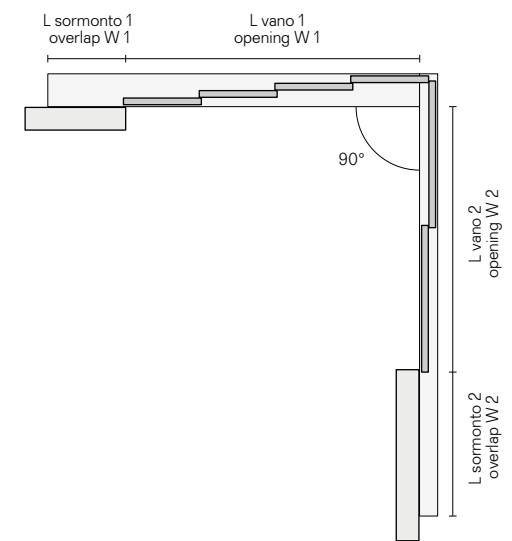

**Porte scorrevoli a scomparsa**  
**Pocket doors**

Porta singola scorrevole  
Single pocket door

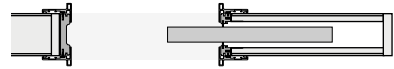
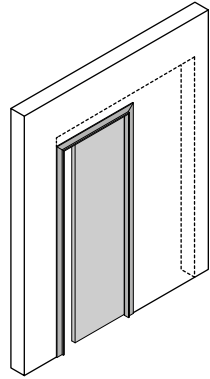

Porta doppia scorrevole  
Double pocket door

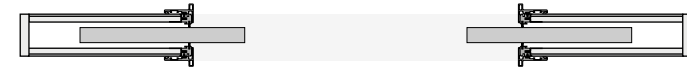
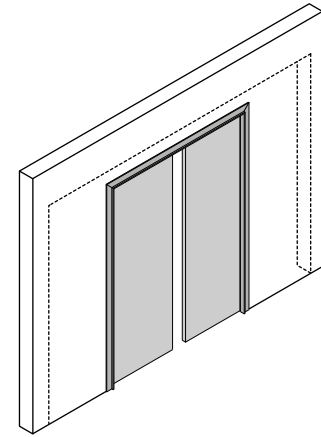

**Tipologie stipite telescopico**  
**Telescopic jamb typologies**

Stipite telescopico standard  
Standard telescopic jamb

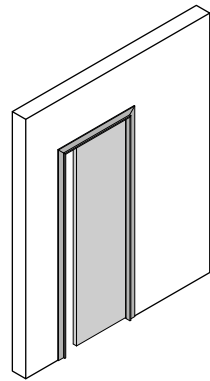

Stipite telescopico slim  
Slim telescopic jamb

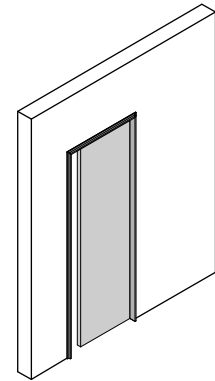

Stipite telescopico mini  
Mini telescopic jamb

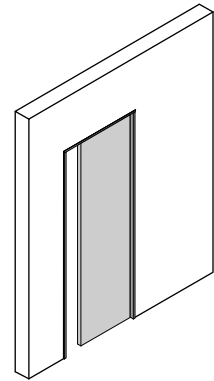

**Descrizione tecnica**  
**Technical description**

Le versioni scorrevoli a scomparsa delle porte Rimadesio sono progettate per integrarsi con i più diffusi controtelai in commercio. Una porta scorrevole a scomparsa si compone di un pannello porta e di uno stipite telescopico, in grado di adattarsi alla differenza di spessore fra le pareti, disponibile nelle versioni standard, con sei varianti estetiche, slim e mini.

Rimadesio pocket doors are designed to be inserted into the most common pocket systems on the market. A pocket door is made up of door panel, telescopic jamb that can be adjusted on different thickness of the walls, available in standard versions, with six aesthetic versions, slim and mini.

Die Schiebetüren die in der Metalltasche in der Mauer laufen sind geeignet für die meisten Mauertaschen die am Markt erhältlich sind. Eine Schiebetüre die in der Metalltasche in der Mauer läuft besteht aus einem Türpanel und einem teleskopischen Türpfosten, der sich an die unterschiedlichen Mauerabstände anpassen kann. Dieser ist standardmäßig erhältlich in sechs verschiedenen Versionen, slim oder mini.

La version galandage de panneaux Rimadesio prévoit une intégration avec les plus connus systèmes à galandage sur le marché. Un panneau galandage complet est composé par un panneau et un jambage télescopique, capable de s'adapter aux différents épaisseur de mur, disponible en version standard, avec six variantes esthétiques, slim et mini.

Las versiones correderas en el muro de las puertas Rimadesio están diseñadas para integrarse con los mas populares contramarcos en el mercado. Una puerta corredera en el muro se compone de una puerta y una jamba telescópica, capaz de adaptarse a la diferencia de espesor entre las paredes, disponible en versiones estándar, con seis variantes estéticas, slim y mini.

**Tipologie estetiche pannelli porta**  
**Aesthetic typologies doors panel**

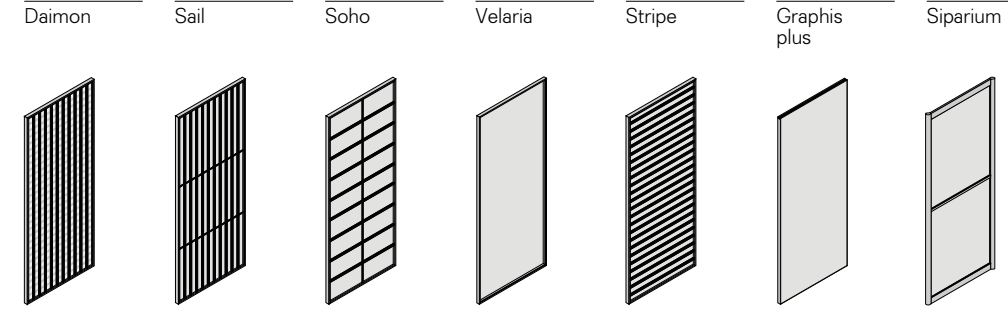

**Dimensioni pannelli porta**  
**Door panel dimensions**

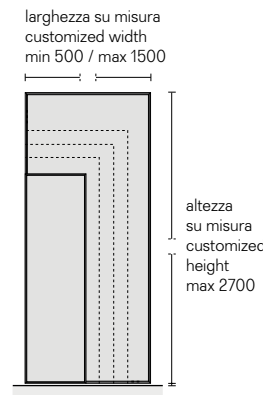

**Descrizione tecnica**  
**Technical description**

Il pannello porta è l'elemento integrante del progetto che dialoga con l'architettura degli spazi, creando soluzioni di forte impatto. La realizzazione, sempre su misura, è consentita fino all'altezza massima di 2700 mm e alla larghezza massima di 1500 mm. La ricerca tecnologica Rimadesio ha permesso di realizzare un pannello porta che rientra completamente nel controtelaio, assicurando la massima qualità estetica di ogni installazione.

Door panel is the integral part of the project, that communicates with spaces architecture, creating strong effect solutions. The production, always custom-made, can reach maximum height of 2700 mm and maximum width of 1500 mm. Rimadesio technological research allowed to realize a door panel that disappears completely into the pocket system, ensuring the highest aesthetic quality for every installation.

Das Türpanel schafft den Dialog zwischen Architektur und Raum, mit Lösungen die eine starken ästhetische Wirkung haben. Die Ausführung ist immer auf Mass, bis zu einer maximalen Höhe von 2700 mm und einer maximalen Breite von 1500 mm. Die Panele können komplett im Blindstock versenkt werden und garantieren eine maximale ästhetische Qualität.

Le panneau est un élément intégral du projet en dialogue avec l'architecture de l'espace, avec des solutions très percutantes. La réalisation, toujours sur mesure, est possible jusqu'à la hauteur maximale de 2700 mm et la largeur maximale de 1500 mm. La recherche technologique Rimadesio a permis de réaliser un panneau totalement escamotable, et donc avec une installation de haute qualité esthétique.

El panel de la puerta es un elemento integrante del proyecto que dialoga con la arquitectura de los espacios, creando soluciones de fuerte impacto. La realización, siempre a medida, está consentida hasta la altura máxima de 2700 mm y la anchura máxima de 1500 mm. La investigación tecnológica Rimadesio ha permitido realizar un panel de puerta que encaja completamente en el contramarco, garantizando la máxima calidad estética de cada instalación.



**Lo stipite telescopico standard**  
**The standard telescopic jamb**

L'esclusivo stipite telescopico permette di compensare lo spessore di eventuali rivestimenti con un'escursione massima di 20 mm per lato.

The exclusive telescopic jamb can compensate for potential coating thickness with a maximum range of 20 mm for each side.

Der exklusive teleskopische Pfosten in Aluminium ermöglicht den Ausgleich eventueller Unterschiede in der Mauerdicke auf beiden Seiten bis zu maximal 20 mm pro Seite.

L'esclusif jambage télescopique peut s'adapter aux différents épaisseur de revêtement mural, pour un maxi de 20 mm chaque côté.

La exclusiva jamba telescópica permite compensar el grosor cualquier revestimiento con una extension máxima de 20 mm por lado.

Stipite telescopico standard per controtelai a scomparsa Scigno® Base e Eclisse® Unico  
 Standard telescopic jamb for systems Scigno® Base and Eclisse® Unico

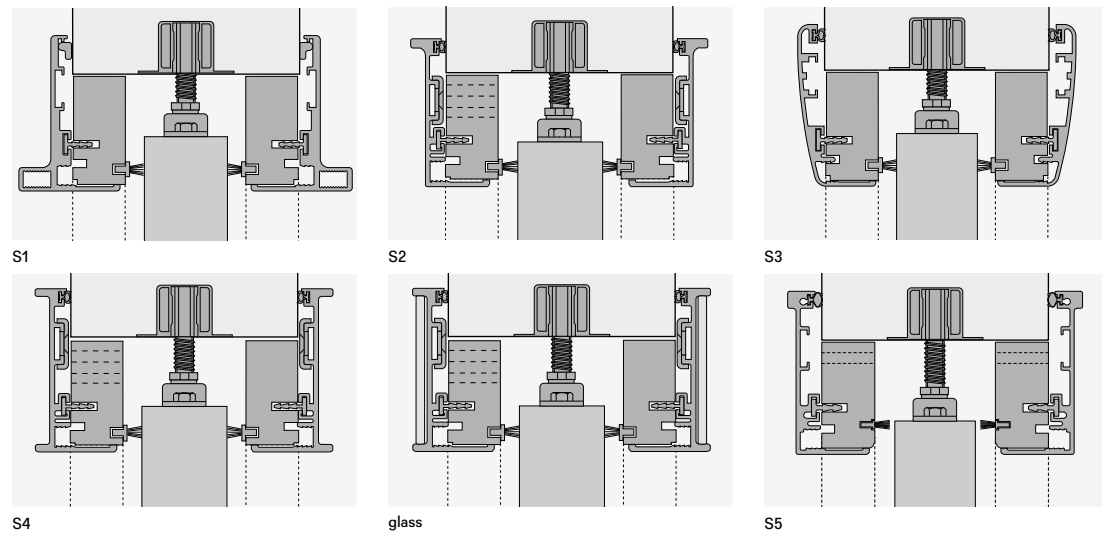

**Calcolo altezze pannelli porte**  
**Door panels heights calculation**

Velaria, Stripe, Sail, Soho, Daimon, Graphis plus, Siparium  
 $H_{\text{pannello}} = H_{\text{panel}}$   
 $H_{\text{falso telaio}} = H_{\text{subframe}} - 40 \text{ mm}$

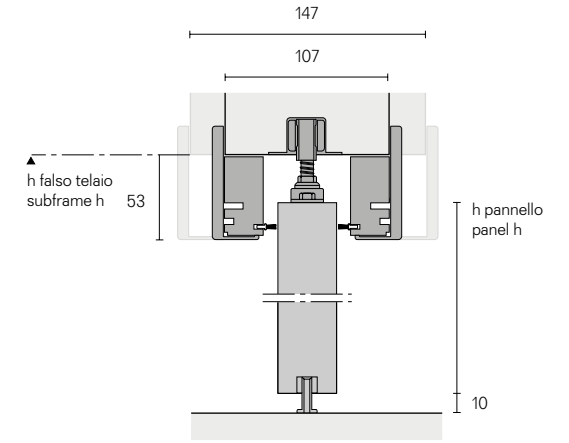

**Calcolo larghezze porta singola**  
**Single door width calculation**

Velaria, Stripe, Sail, Soho, Daimon  
 $L_{\text{pannello}} = L_{\text{panel}}$   
 $L_{\text{falso telaio}} = L_{\text{subframe}} - 35 \text{ mm}$

Graphis plus, Siparium  
 $L_{\text{pannello}} = L_{\text{panel}}$   
 $L_{\text{falso telaio}} = L_{\text{subframe}} - 20 \text{ mm}$

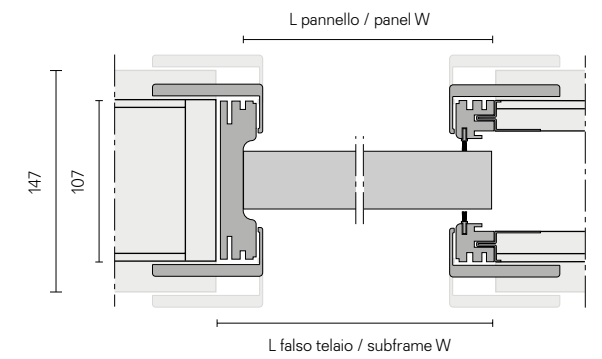

**Calcolo larghezze porta doppia**  
**Double door width calculation**

Velaria, Stripe, Sail, Soho, Daimon  
 $L_{\text{pannello}} = L_{\text{panel}}$   
 $(L_{\text{falso telaio}} - 20 \text{ mm}) \div 2$

Graphis plus, Siparium  
 $L_{\text{pannello}} = L_{\text{panel}}$   
 $(L_{\text{falso telaio}}) \div 2$

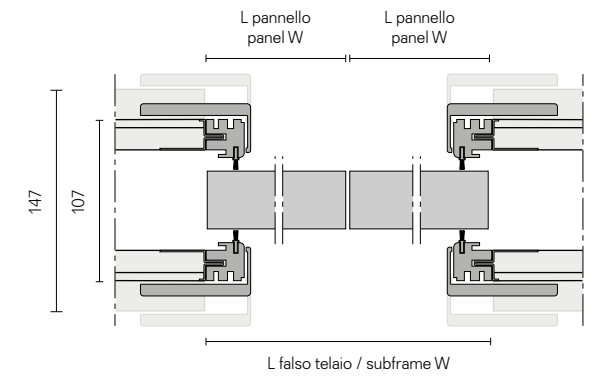

**Lo stipete telescopico slim**  
The slim telescopic jamb

L'esclusivo stipete telescopico permette di compensare lo spessore di eventuali rivestimenti con un'escursione massima di 17 mm per lato.

The exclusive telescopic jamb can compensate for potential coating thickness with a maximum range of 17 mm for each side.

Der exklusive teleskopische Pfosten in Aluminium ermöglicht den Ausgleich eventueller Unterschiede in der Mauerdicke auf beiden Seiten bis zu maximal 17 mm pro Seite.

L'exclusif jambage télescopique peut s'adapter aux différents épaisseurs de revêtement mural, pour un maxi de 17 mm chaque côté.

La exclusiva jamba telescópica permite compensar el grosor cualquier revestimiento con una extensión máxima de 17 mm por lado.

Stipete telescopico slim per controtelai a scomparsa Scrigno® Essential e Eclisse® Syntesis Line  
Telescopic slim jamb for systems Scrigno® Essential and Eclisse® Syntesis Line

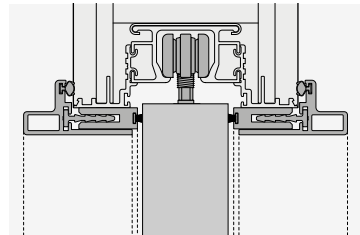

Tipologie d'installazione  
Installation typologies

Parete in cartongesso  
Plasterboard wall

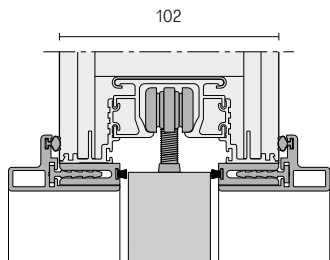

Parete in laterizio  
Brick wall

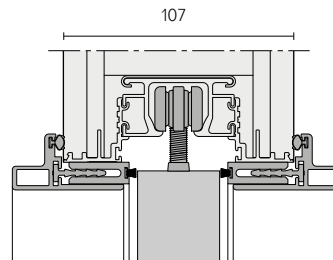

Parete in laterizio o cartongesso  
Brick wall or plasterboard wall

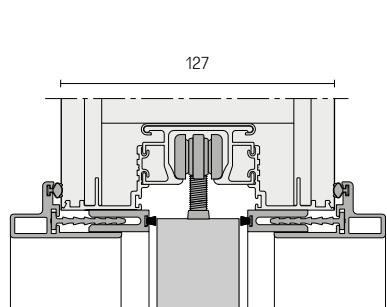

Parete in laterizio o cartongesso (sp. 107 mm + rivestimento)  
Brick wall or plasterboard wall (thk 107 mm + covering)

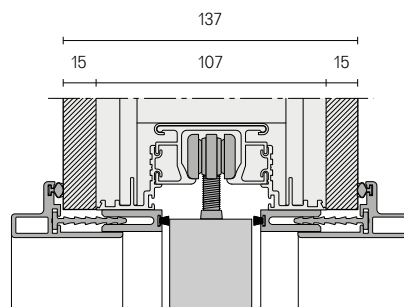

Calcolo altezze pannelli porte  
Door panels heights calculation

Velaria, Stripe, Sail, Soho, Siparium, Daimon  
 $H_{\text{pannello}} H_{\text{panel}} =$   
 $H_{\text{falso telaio}} H_{\text{subframe}} - 10 \text{ mm}$

Graphis plus  
 $H_{\text{pannello}} H_{\text{panel}} =$   
 $H_{\text{falso telaio}} H_{\text{subframe}} - 15 \text{ mm}$

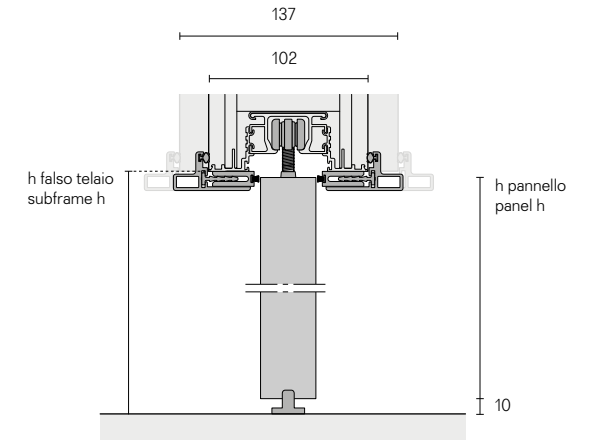

Calcolo larghezze porta singola  
Single door width calculation

Velaria, Stripe, Sail, Soho, Daimon  
 $L_{\text{pannello}} W_{\text{panel}} =$   
 $L_{\text{falso telaio}} W_{\text{subframe}} + 2 \text{ mm}$

Graphis plus  
 $L_{\text{pannello}} W_{\text{panel}} =$   
 $L_{\text{falso telaio}} W_{\text{subframe}} + 10 \text{ mm}$

Siparium  
 $L_{\text{pannello}} W_{\text{panel}} =$   
 $L_{\text{falso telaio}} W_{\text{subframe}} + 14 \text{ mm}$

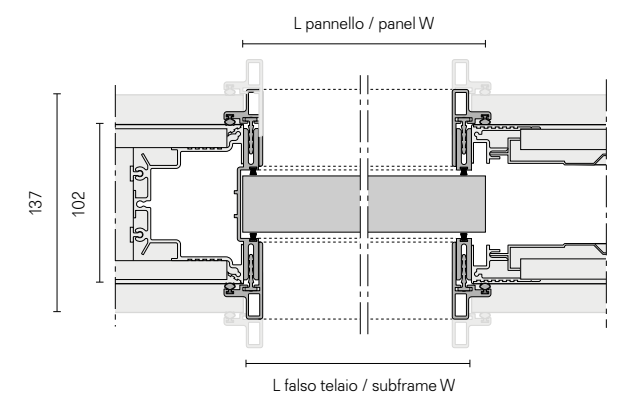

Calcolo larghezze porta doppia  
Double door width calculation

Velaria, Stripe, Sail, Soho, Daimon  
 $L_{\text{pannello}} W_{\text{panel}} =$   
 $(L_{\text{falso telaio}} W_{\text{subframe}} + 4 \text{ mm}) \div 2$

Siparium  
 $L_{\text{pannello}} W_{\text{panel}} =$   
 $(L_{\text{falso telaio}} W_{\text{subframe}} + 24 \text{ mm}) \div 2$

Graphis plus  
 $L_{\text{pannello}} W_{\text{panel}} =$   
 $(L_{\text{falso telaio}} W_{\text{subframe}} + 20 \text{ mm}) \div 2$

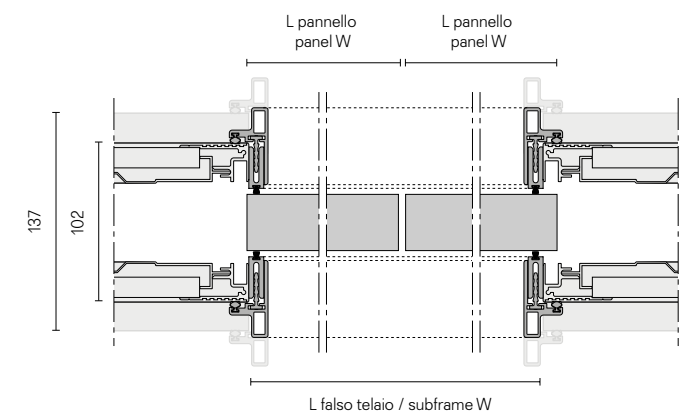

## Lo stipete telescopico mini The mini telescopic jamb

L'esclusivo stipete telescopico permette di compensare lo spessore di eventuali rivestimenti con un'escursione massima di 17 mm per lato.

The exclusive telescopic jamb can compensate for potential coating thickness with a maximum range of 17 mm for each side.

Der exklusive teleskopische Pfosten in Aluminium ermöglicht den Ausgleich eventueller Unterschiede in der Mauerdicke auf beiden Seiten bis zu maximal 17 mm pro Seite.

L'exclusif jambage télescopique peut s'adapter aux différents épaisseur de revêtement mural, pour un maxi de 17 mm chaque côté.

La exclusiva jamba telescópica permite compensar el grosor cualquier revestimiento con una extensión máxima de 17 mm por lado.

Stipete telescopico mini per controtelai a scomparsa Scigno® Essential e Eclisse® Syntesis Line  
Telescopic mini jamb for systems Scigno® Essential and Eclisse® Syntesis Line

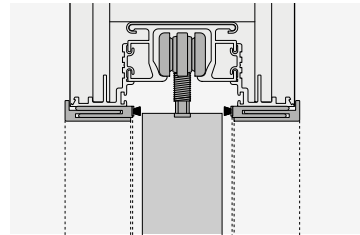

Tipologie d'installazione  
Installation typologies

Parete in cartongesso  
Plasterboard wall

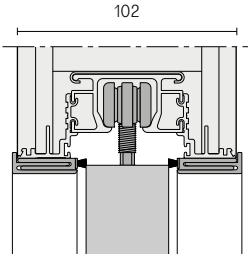

Parete in laterizio  
Brick wall

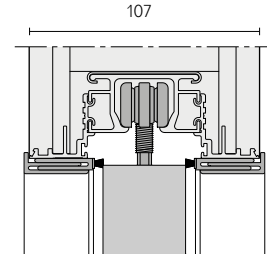

Parete in laterizio o cartongesso  
Brick wall or plasterboard wall

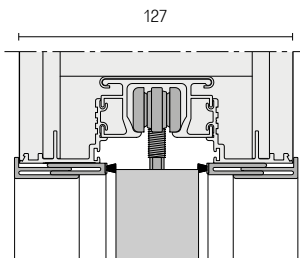

Parete in laterizio o cartongesso  
(sp. 107 mm + rivestimento)  
Brick wall or plasterboard wall (thk 107 mm + covering)

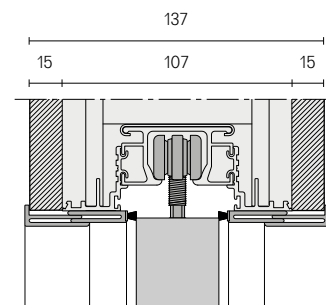

Calcolo altezze pannelli porte  
Door panels heights calculation

Velaria, Stripe, Sail, Soho, Daimon, Siparium  
H pannello  $H_{panel} =$   
H falso telaio  $H_{subframe} - 7$  mm

Graphis plus  
H pannello  $H_{panel} =$   
H falso telaio  $H_{subframe} - 13$  mm

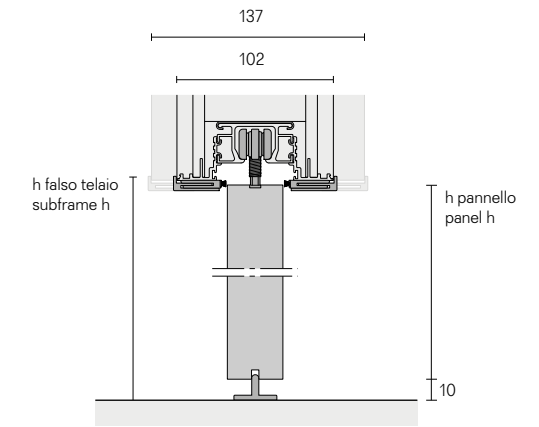

Calcolo larghezze porta singola  
Single door width calculation

Velaria, Stripe, Sail, Soho, Daimon, Graphis plus  
L pannello  $W_{panel} =$   
L falso telaio  $W_{subframe} + 7$  mm

Siparium  
L pannello  $W_{panel} =$   
L falso telaio  $W_{subframe} + 23$  mm

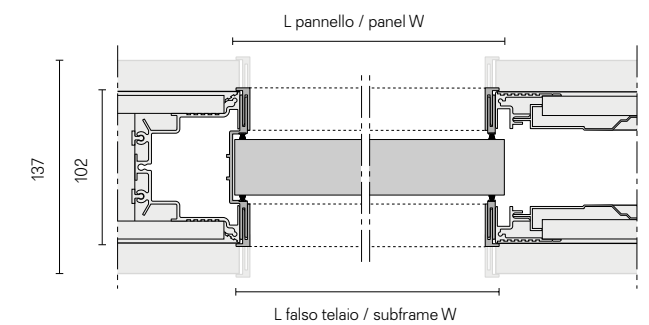

Calcolo larghezze porta doppia  
Double door width calculation

Velaria, Stripe, Sail, Soho, Daimon  
L pannello  $W_{panel} =$   
(L falso telaio  $W_{subframe} + 7$  mm)  $\div 2$

Siparium  
L pannello  $W_{panel} =$   
(L falso telaio  $W_{subframe} + 36$  mm)  $\div 2$

Graphis plus  
L pannello  $W_{panel} =$   
(L falso telaio  $W_{subframe} + 14$  mm)  $\div 2$

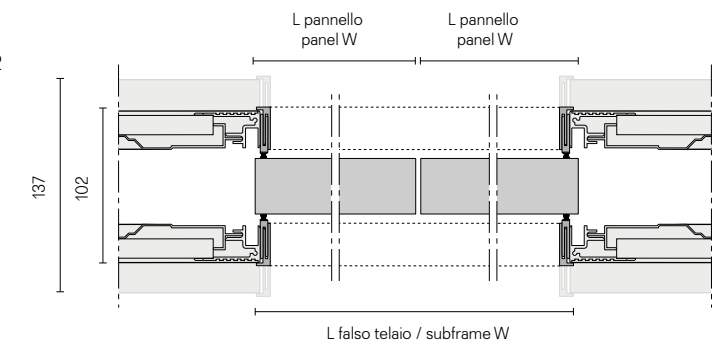

Vetri laccati Ecolorsystem  
Ecolorsystem lacquered glasses

Lucidi Glossy	Opachi Mat	Lucidi Glossy	Opachi Mat	Lucidi Glossy	Opachi Mat	Lucidi Glossy	Opachi Mat	Lucidi Glossy	Opachi Mat
40	115	53	95	45	97	50	108	76	116
35	100	56	98	85	130	74	110	84	128
86	131	41	104	69	126	51	113	300	133
47	96	88	132	57	106	52	107	301	134
36	117	48	103	58	99	73	109	83	127
	122			46	102	43	119	302	135
						33	111	303	136

Caratteristiche

Ecolorsystem è la denominazione che contraddistingue l'esclusiva collezione di vetri laccati Rimadesio, disponibili in finitura lucida e opaca. Colori ecologici perché prodotti utilizzando esclusivamente vernici all'acqua di ultima generazione, con cottura a 110 °C. Una tecnologia produttiva all'avanguardia nell'ambito del vetro, con impianti interni totalmente robotizzati che assicurano risultati di altissima qualità e un ciclo di lavorazione a basso impatto ambientale. Resistenza alla corrosione conforme alla norma UNI EN ISO 9227. Resistenza agli sbalzi di temperatura conforme alla norma UNI 9429. Colori inalterabili nel tempo perché applicati sulla superficie interna del vetro, al sicuro da macchie, polvere e umidità. Lo spessore del vetro crea un esclusivo effetto di "profondità".

Vetri laccati lucidi

Superficie perfettamente liscia. Brillantezza equivalente a 100 gloss. Vetri non trasparenti, caratterizzati dall'alto potere riflettente. Resistenza alla graffiatura superiore rispetto alle convenzionali superfici laccate.

Vetri laccati opachi

Superficie con effetto vellutato al tatto. Vetri non trasparenti, caratterizzati da un effetto di opacità molto marcato. Microsolcatura superficiale che conferisce un'elevata resistenza alla graffiatura. Refrattari alle impronte digitali.

Characteristics

Ecolorsystem is the name that distinguishes the exclusive Rimadesio lacquered glass collection in glossy and mat finishing. Ecological colours produced, using exclusively water paints of latest generation, cooked at 110 °C. Cutting edge production technology in the area of glass, with a fully robotised in-house plant that ensures very high quality results and a low environmental impact work cycle. Corrosion resistance conforms to the UNI EN ISO 9227 standard. Temperature fluctuation resistance conforms to the UNI 9429 standard. The colour is inside the double glass, safe from stains, dust and humidity. The thickness of the glass creates an exclusive "depth" effect.

Glossy lacquered glasses

Perfectly smooth surface. Brightness equivalent to 100 gloss. Not transparent glass, characterized by high reflectivity. Higher scratch resistance compared to conventional painted surfaces.

Mat lacquered glasses

Surface with velvet touch effect. Not transparent glasses, characterized by a very marked opacity effect. Surface high resistant to scratching. Refractory to fingerprints.

Eigenschaften

Ecolosystem ist der Name der neuen lackierten Glas-Kollektion von Rimadesio. Absolut oekologische Farben, da die modernsten Lackierungen, auf Wasser-Basis, an einer Temperatur von 110 °C gekocht werden. Eine fortschrittliche Produktionstechnik in der Glasverarbeitung auf einer vollautomatisierten Anlage, die Ergebnisse höchster Qualität und gleichzeitig umweltfreundliche Verarbeitungsverfahren gewährleistet. Korrosionsprüfung gemäß Bestimmung UNI EN ISO 9227. Temperaturwechselprüfung gemäß Bestimmung UNI 9429. Die Farben sind unveränderlich, weil es auf die innere Oberfläche des Glases, sicher vor Flecken, Staub und Feuchtigkeit aufgetragen. Die Dicke des Glases erzeugt eine einzigartige Wirkung von "Tiefe".

Hochglanzend lackierte Gläser

Glaeser Vollkommen glatte Oberfläche. Helligkeit entsprechend 100 Gloss. Undurchsichtige Glaeser, durch eine hohe Reflektivität gekennzeichnet. Hoehere Kratzfestigkeit zu herkömmlichen lackierten Oberflächen verglichen.

Matt lackierte Gläser

Oberfläche mit "Velvet touch" Effekt. Undurchsichtige Glaeser, gekennzeichnet durch einen Matt-Effekt sehr ausgeprägt. Oberfläche, die eine hohe Resistenz gegen Kratzer gibt. Groesse Widerstand an Fingerabdrücke.

Caractéristiques

Ecolorsystem est le nom qui caractérise la collection exclusive de verres laqués de Rimadesio. Couleurs écologiques, parce que produites en utilisant exclusivement vernis à l'eau de dernière génération, cuites à 110 °C. Une technologie de production avant-gardiste dans le domaine du verre, avec des équipements internes entièrement robotisés qui assurent des résultats de grande qualité et un cycle de production ayant un impact très faible sur l'environnement. Résistance à la corrosion conformément à la norme UNI EN ISO 9227. Résistance aux écarts de température conformément à la norme UNI 9429. Couleurs inaltérables parce que appliquée sur la surface interne du verre, à l'abri des taches, poussière et l'humidité. L'épaisseur du verre crée un effet unique de "profondeur".

Verres laqués brillants

Surface parfaitement lisse. Luminosité équivalent à 100 Gloss. Verres pas transparents, caractérisé par une haute réflectivité. Résistance aux rayures supérieure par rapport aux conventionnelles surfaces peintes.

Verres laqués mats

Surface avec effet toucher velours. Verres pas transparents avec caractéristique d'opacité très marquée. Surface avec une haute résistance aux rayures. Réfractaires aux empreintes digitales.

Características

Ecolorsystem es la denominación que marca la exclusiva colección de los cristales lacados Rimadesio, disponibles en acabado brillante y opaco. Colores ecológicos porque productos utilizando exclusivamente pinturas al agua de última generación, con cocción a 110 °C. Una tecnología productiva a la vanguardia en el ámbito del cristal, con unas instalaciones internas totalmente robotizadas que aseguran resultados de altísima calidad y un ciclo de tratamiento respetuoso del medio ambiente. Resistencia a la corrosión conforme a la norma UNI EN ISO 9227. Resistencia a las variaciones de temperatura conforme a la norma UNI 9429. Colores inalterables en el tiempo, porque aplicados en la superficie interna del cristal, al resguardo de manchas, polvo y humedad. El grosor del cristal crea un exclusivo efecto de "profundidad".

Cristales lacados brillantes

Superficie perfectamente lisa. Brillantez equivalente a 100 gloss. Cristales no transparentes, del alto poder reflectante.

Cristales lacados opacos

Superficie con efecto aterciopelado al tacto. Cristales no transparente, del característico efecto de opacidad muy marcado. Microsurcos superficiales con alta resistencia a las rayas. Refractarios a las huellas dactilares.