

ITEM	QTY	PART NUMBER	DESCRIPTION
1	1		servo assembly
2	4	AN526-10R8	1/2" machine screw
3	2	AN526-10R14	7/8" machine screw
4	2	AN960-10	washer
5	1		pushrod assembly
6	2	MS20365-1032	self locking nut
7	1		torque tube actuator arm
8	4	MS35333-39	internal tooth lockwasher

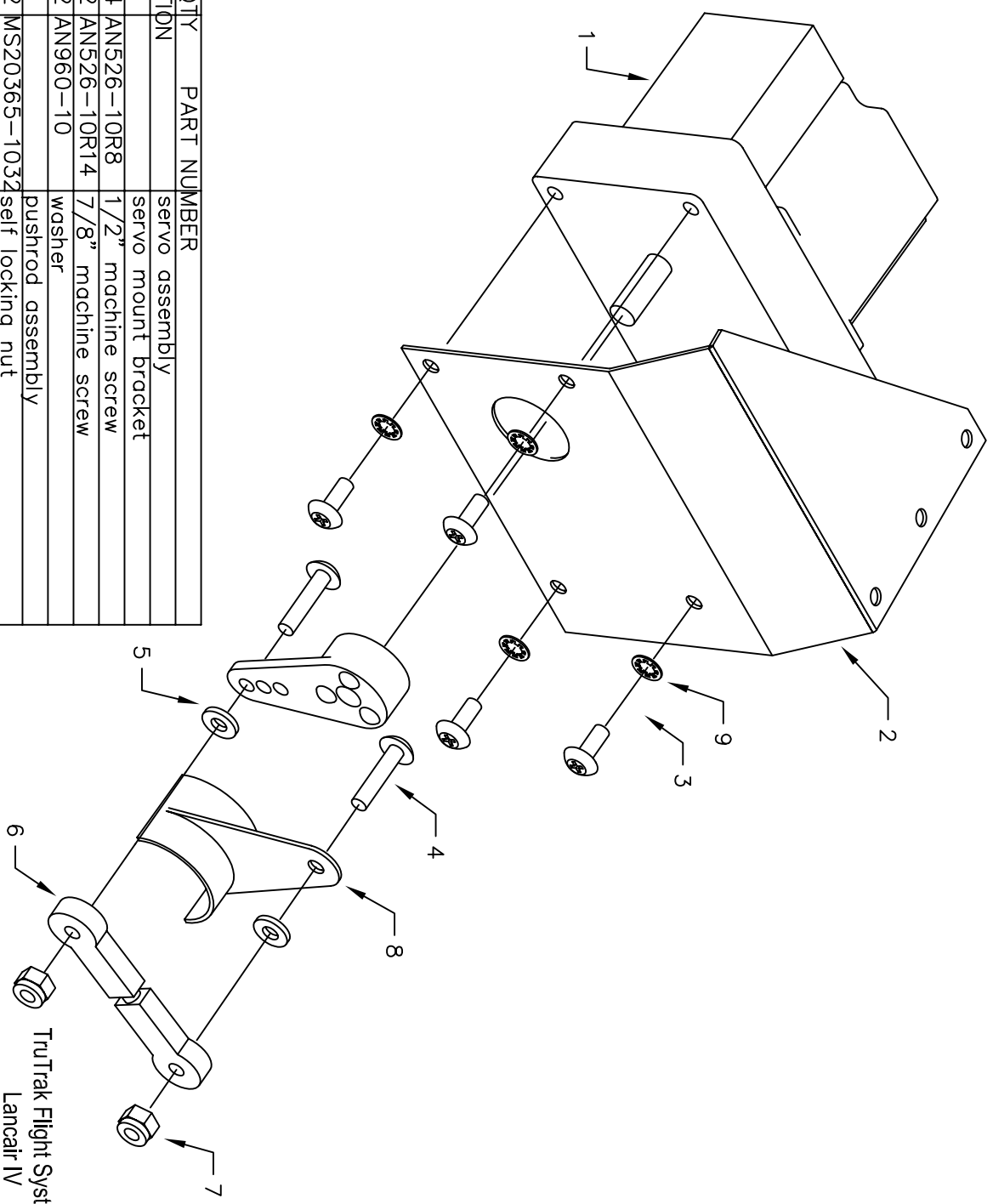

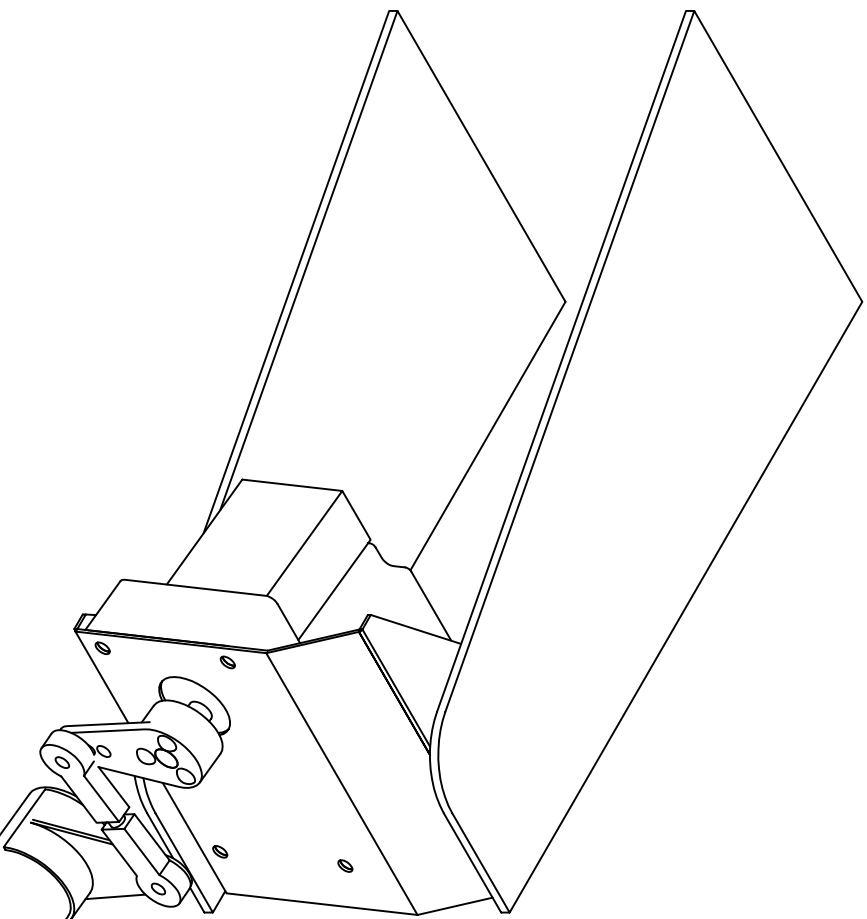

With aileron control centered, attach actuator arm in vertical position. With torque tube actuator arm vertical, locate servo position so that servo arm is vertical. Position servo mounting bracket fore/aft so as to align servo arm with torque tube actuator arm.

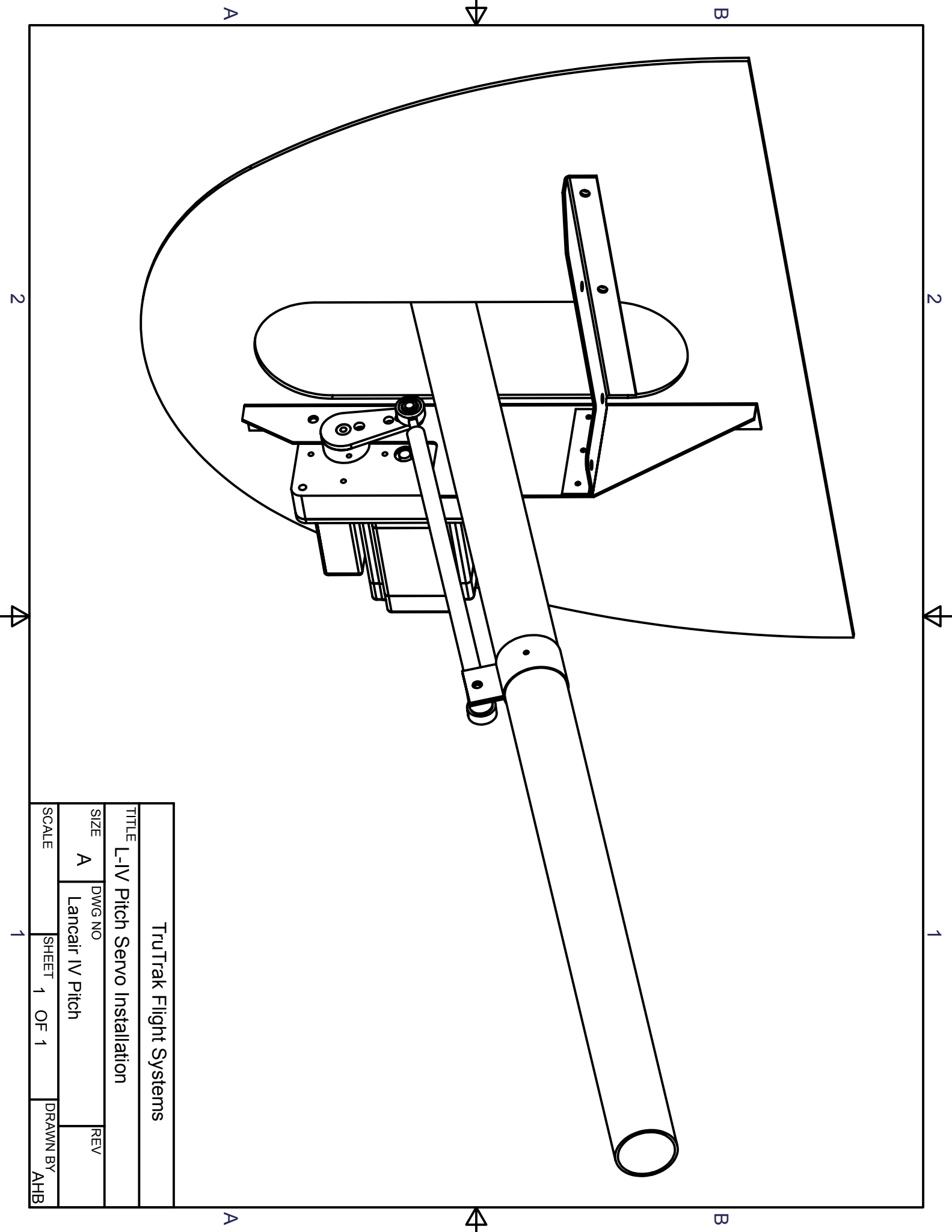

TruTrak Flight Systems

TITLE
L-IV Pitch Servo Installation

SIZE
A

SCALE
1

DWG NO

Lancair IV Pitch

REV

SHEET 1 OF 1

DRAWN BY
AHB

ITEM	QTY	PART NUMBER	DESCRIPTION
1	1		SERVO MOUNT BRACKET
2	1	DSP-C	ASSY.
3	3	AN526-10R8	PITCH SERVO ASSY.
4	9	MS35333-39	1/2" MACHINE SCREW
5	2	AN526-10R14	LOCK WASHER
6	4	AN960-10	7/8" MACHINE SCREW
7	2	MM-3	WASHER
8	2	MS20365-103	ROD END BEARING
9	2	AN315-3	SELF LOCKING NUT
10	1		NUT
11	1		PUSHROD
12	6	AN526-10R12	PUSH/PULL TUBE BRACKET

3/4" MACHINE SCREW

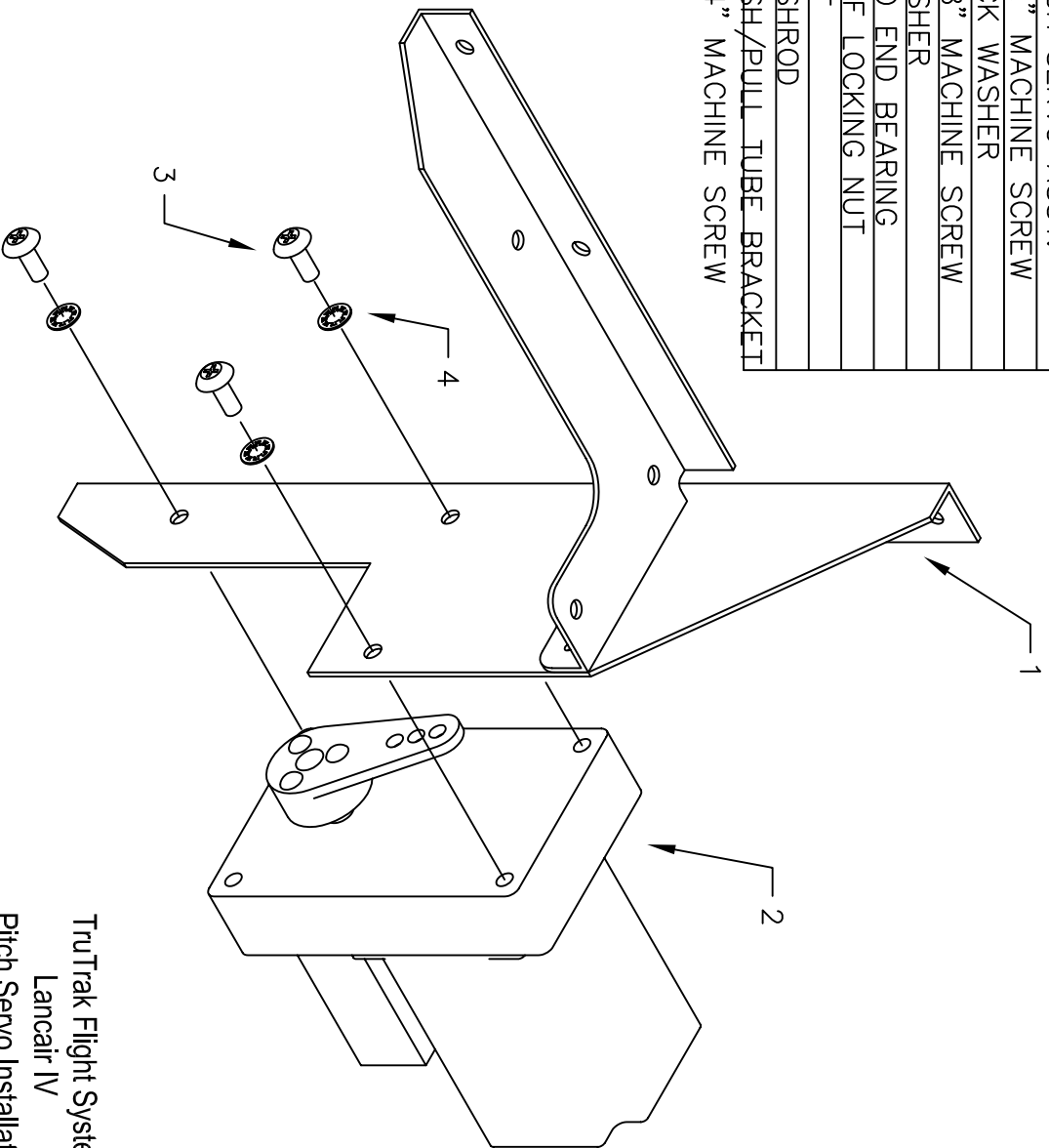

TruTrak Flight Systems
Lancair IV
Pitch Servo Installation