



# TRUTRAK

—THE AUTOPILOT PEOPLE—

**Installation Manual**  
**For**  
  
8300-013 Rev J  
**Automatic Pitch Trim**



TRUTRAK FLIGHT SYSTEMS

**1488 S. Old Missouri Road**  
**Springdale, AR 72764**

POSTAL SERVICE ADDRESS

P.O. Box 189  
Springdale AR 72765-0189

**Ph: 479-751-0250 Fax: 479-751-3397**

[www.trutrakap.com](http://www.trutrakap.com)

**IT IS THE INSTALLERS RESPONSIBILITY TO ENSURE THAT THE TRIM SYSTEM DOES NOT EXCEED THE ABILITY OF THE PILOT TO CONTROL THE AIRCRAFT AT ANY SPEED WITH THE TRIM TAB AT FULL DEFLECTION IN EITHER POSITION.**

**IF UNABLE TO MAINTAIN FLIGHT CONTROL WITH THE TRIM TABS AT FULL DEFLECTION THEN STOPS WILL BE NEEDED IN THE AIRCRAFT TRIM SYSTEM.**

## Table of Contents

<b>Electrical Pin-Out</b> .....	3
<b>Pitch Auto Trim Block Diagram</b> .....	5
<b>28 Volt Aircraft with 12 Volt Trim System</b> .....	6
<b>Trouble Shooting</b> .....	7
Autotrim Ground Setup.....	8
Autotrim Ground Checkout (Do this before first flight with the autotrim) .....	8
Autotrim Status Lamp Indications.....	8
Autotrim Checkout Flowchart (All tests performed at the elevator surface, not at the stick/yoke) .....	9
<b>RETURN MERCHANDISE POLICY</b> .....	11
Autotrim Dimensions .....	12

<b>Revision</b>	<b>Date</b>	<b>Discription</b>	<b>Pages</b>
<b>C</b>	<b>12/22/2009</b>	<b>New auto trim module</b>	<b>All</b>
<b>D</b>	<b>06/03/2011</b>	<b>Updated trouble guide</b>	<b>1, 5 &amp; 6</b>
<b>E</b>	<b>2/23/2015</b>	<b>Updated for new autotrim design</b>	<b>All</b>
<b>F</b>	<b>3/2/2015</b>	<b>Corrected diagrams for LED</b>	<b>4-6</b>
<b>G</b>	<b>3/30/2015</b>	<b>Corrected setup procedure</b>	<b>9</b>
<b>H</b>	<b>7/13/2017</b>	<b>Added note to diagrams for LED polarity</b>	<b>4-6</b>
<b>I</b>	<b>10/23/2017</b>	<b>Corrected Pin 16 Connection</b>	<b>4</b>
<b>J</b>	<b>10/30/2017</b>	<b>Corrected Flowchart</b>	<b>9</b>

## Electrical Pin-Out

The table below provides a brief explanation of each pin function on the 25-pin connector P101.

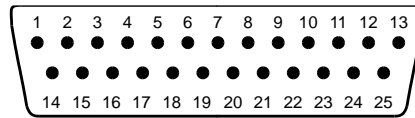

25-Pin Connector P101

P101 Pin	Function	Notes
1	<b>No Connection.</b> Reserved for future expansion.	
2	<b>No Connection.</b> Reserved for future expansion.	
3	<b>Pitch Servo Trim Sensor.</b> Pitch servo trim sensor output to autopilot programmer.	@2.5 v AP engaged no load
4	<b>Pitch Servo Trim Sensor.</b> Pitch servo trim sensor input from pitch servo pin 7.	@2.5 v AP engaged no load
5	<b>Torque Control.</b> Pitch servo torque control input from autopilot programmer.	@5 volt, AP engaged
6	<b>Torque Control.</b> Pitch servo torque control output to pitch servo.	@5 volt, AP engaged
7	<b>LED Lamp Output.</b> LED status lamp output	
8	<b>Trim motor control 1.</b> Line 1 to existing Trim motor control system.	
9	<b>Motor 1.</b> Line 1 to existing trim servo motor. <b>Will not control relays</b>	Voltage in @max 5 amps
10	<b>Motor 2.</b> Line 2 to existing trim servo motor. <b>Will not control relays</b>	Voltage in @max 5 amps
11	<b>Trim motor control 2.</b> Line 2 to existing Trim motor control system.	
12	<b>Power.</b> Connects to autopilot master or pitch servo power line from programmer.	11 – 35V input
13	<b>Power.</b> Connects to pitch servo pin 1.	
14	<b>Ground.</b> Ground connection	
15	<b>Ground.</b> Connect to aircraft ground.	Aircraft ground
16	<b>No Connection.</b> Reserved for future expansion.	
17	<b>No Connection.</b> Reserved for future expansion.	
18	<b>PH1P.</b> Servo drive line output to pitch servo pin 3.	
19	<b>PH1P.</b> Servo drive line input from programmer	
20	<b>PH1N.</b> Servo drive line output to pitch servo pin 2.	
21	<b>PH1N.</b> Servo drive line input from programmer	
22	<b>PH2P.</b> Servo drive line output to pitch servo pin 5.	
23	<b>PH2P.</b> Servo drive line input from programmer	
24	<b>PH2N.</b> Servo drive line output to pitch servo pin 4.	
25	<b>PH2N.</b> Servo drive line input from programmer	

The Trim motor control from the pilot trim switch system will pass through the Auto Trim module when the Auto Pilot is **NOT ENGAGED** through a normally closed relay internally. Once the Auto Pilot is engaged the Auto Trim will open the relay and pulse the voltage that is applied to pin 12 / 13 and ground on pins 9 and 10 according to which direction the sense voltage from the Pitch Servo indicates to drive the trim motor. This control voltage and ground **MUST** be connected to the trim motor **ONLY**, it will not drive the trim relay system.

Total Weight	Voltage	Current	Trim Motor Output
.5 LB	11 V – 35 V	.25 A – 5 A	Input voltage / 5 Amps

# Retrofit to existing autopilot harness

## Long leg of LED connects to 12 V

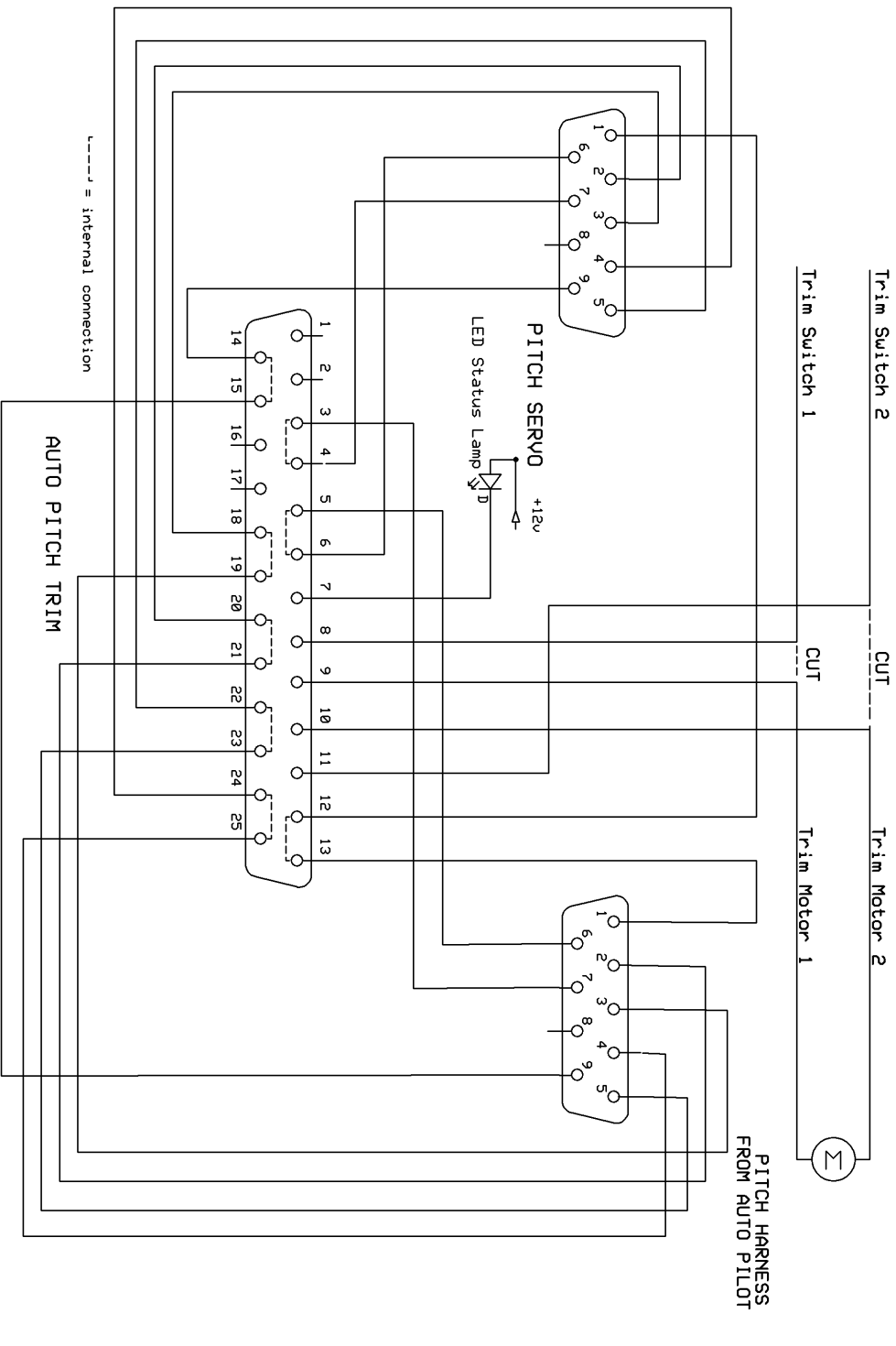

# Pitch Auto Trim Block Diagram

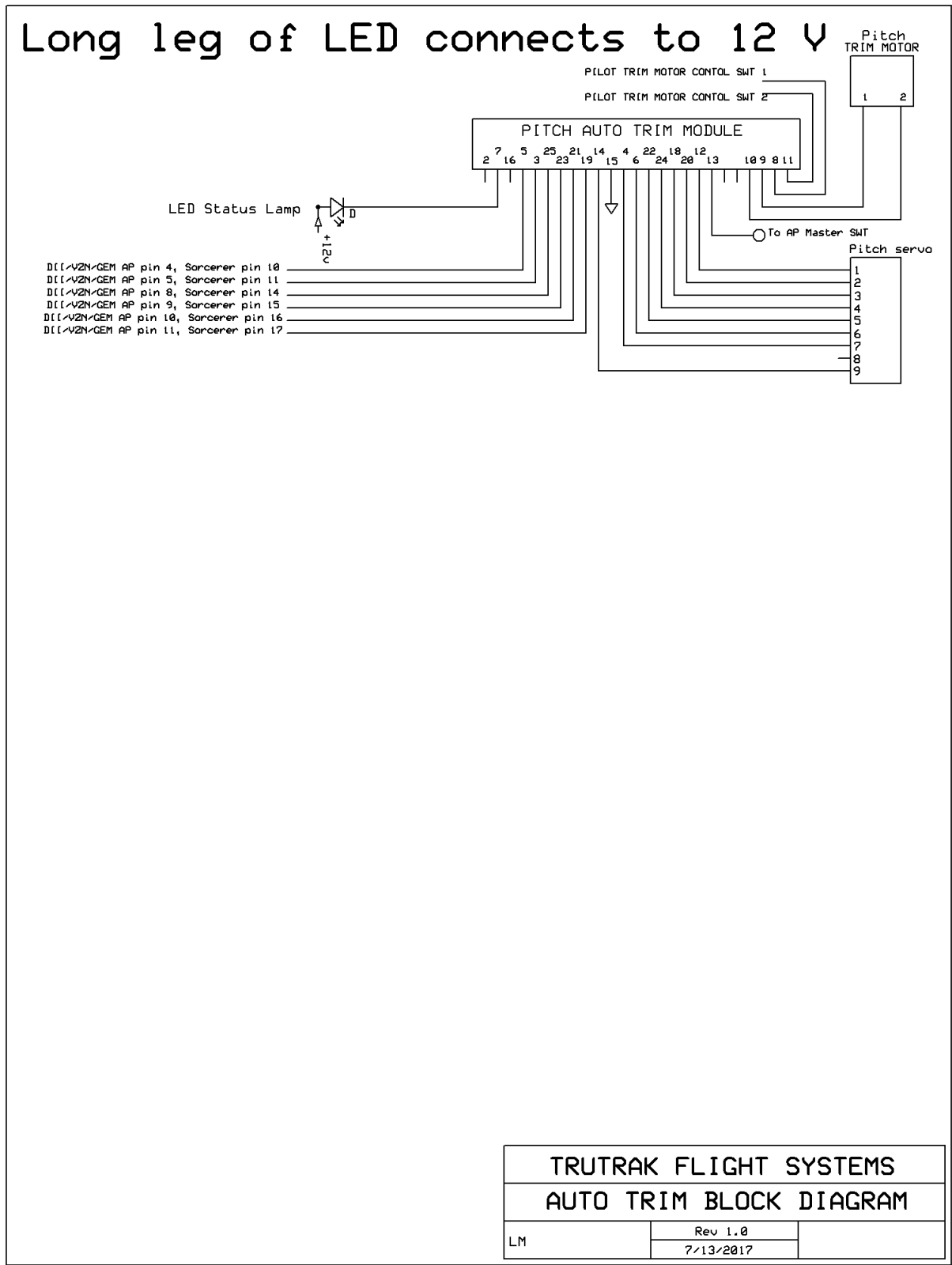

## 28 Volt Aircraft with 12 Volt Trim System

The Voltage that is supplied to the Auto Trim system will drive the trim motor with the same voltage when the Auto Trim system is in operation. The pitch servo and the auto trim system do NOT need to be supplied with the same voltage to work correctly.

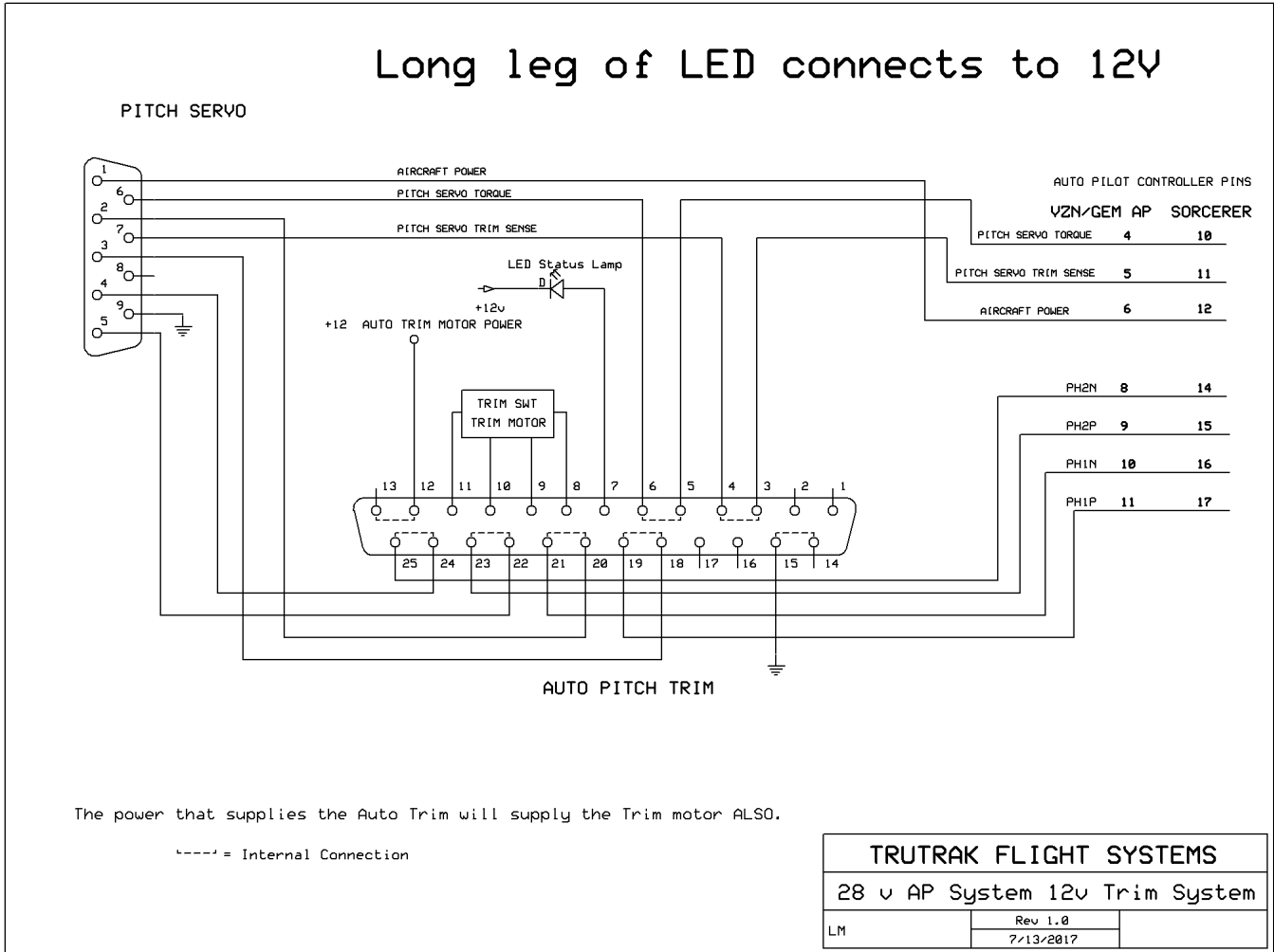

## Trouble Shooting

<b>Problem</b>	<b>Cause</b>	<b>Corrective Action</b>
Trim motor will not move with control pressure <b>and</b> manual trim control is functional	No aircraft voltage and/or torque voltage to auto trim system	Correct power, ground, & torque wiring Engage auto pilot before testing
Trim motor will not move & manual trim control nonfunctional	Trim sense voltage incorrect with auto pilot engaged from pitch servo pin 7	Check 2.5 voltage at pin 3 or 4 Voltage will increase or decrease with elevator pressure
Trim motor only runs in one direction	Auto trim motor control wires not connected to trim motor (relays).	Auto trim motor control wires must be connected to the trim motor only.
Trim bar briefly shows on autopilot display	Auto trim controller speed too slow	Adjust trim speed via setup mode
Aircraft hunts up & down in pitch	Auto trim controller speed too high	Adjust trim speed via setup mode



## Autotrim Installation

-The autotrim module can be mounted in any location, in any orientation. Generally it is installed near the pitch servo to minimize the wire length required for installation.

-The LED status lamp can also be installed in any location desired. However, it must be visible for the setup procedure. The lamp will also indicate a failure so having it visible even during normal operation is beneficial. NOTE: The status lamp is NOT the LED on the side of the autotrim module itself.

## Autotrim Ground Setup

-The autotrim ground setup is a simple process outlined below. The autotrim module pulses the trim motor instead of running it continuously. This prevents a rapid trim runaway in case the ground check was not completed properly. This ground setup process describes

- 1) Power up the autopilot system. The LED status lamp should illuminate and stay lit for no more than five seconds. Once the lamp goes out, move to step 2.
- 2) Engage the autopilot then press and hold one direction on the aircraft trim switch for 10 seconds. After 10 seconds, the status lamp will illuminate again and stay lit until the trim switch is released. Release the trim switch.
- 3) The status lamp will now flash at the currently selected autotrim speed. Tapping one of the trim switches will adjust the speed slower, tapping the other switch will adjust it faster. Which is which depends on how it was wired, so it is not a constant. The speed of the lamp flash will adjust with each switch tap.
- 4) Once the desired speed is set, simply do not press any trim switch for 10 seconds. The status lamp will stop flashing. This indicates the autotrim is no longer in setup mode and the desired trim speed has been saved.
- 5) Setup is complete, disengage the autopilot and proceed to Autotrim Ground Checkout.

## Autotrim Ground Checkout (Do this before first flight with the autotrim)

-Once installation and setup is complete, follow the below checkout procedure before flying with the autotrim for the first time. Following this procedure will prevent runaway trim conditions in flight.

- 1) Verify that the manual trim control moves the trim tab in the appropriate direction.
- 2) Center the elevator control then engage the autopilot.
- 3) Gently apply pressure downward on the elevator, not from the stick but from the actual elevator.
- 4) The trim tab should move downward as well. If the trim tab moves up, the autotrim direction is reversed so the switch on the side of the autotrim will need to be flipped. Once it is flipped, repeat steps 2-4.

## Autotrim Status Lamp Indications

-The LED status lamp four different indications:

- 1) Steady On at Power Up: This is the self-test of the autotrim module. This lasts no more than five seconds right as power is applied to the autopilot system.
- 2) Steady On during Ground Setup: This indicates that the autotrim is entering setup mode so the autotrim speed can be adjusted.
- 3) Flashing during Ground Setup: This flashing indicates the speed the autotrim will pulse the trim motor.
- 4) Steady On during Normal Flight Operation: This indicates that the autotrim has detected an internal failure and will no longer function. Manual trim control will be restored if this occurs.

## Autotrim Checkout Flowchart (All tests performed at the elevator surface, not at the stick/yoke)

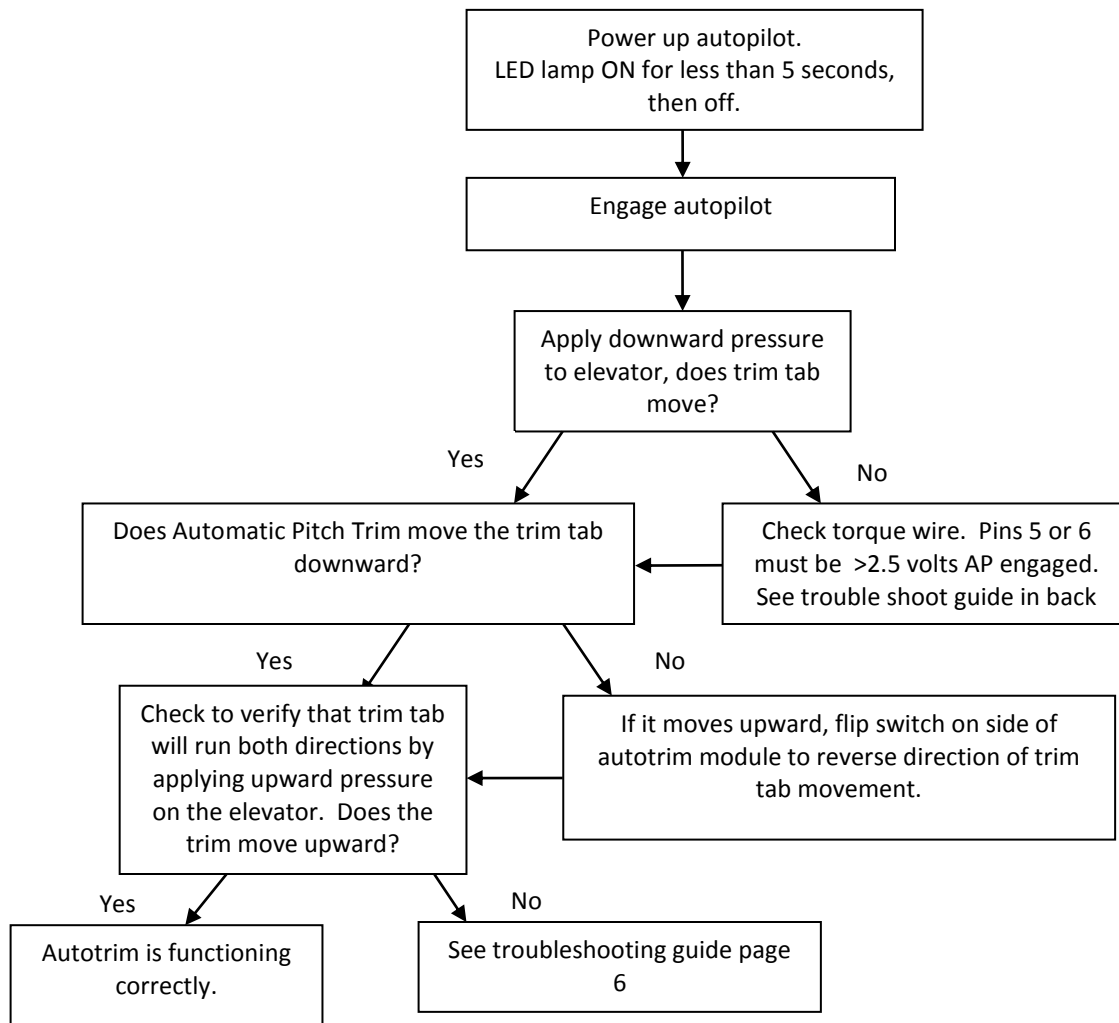

**Note:** If the above technique has been completed and the automatic trim module still does not run the trim, then first try applying more force to the system when holding the up elevator. If the pitch servo slips easily when holding the force, ensure that the pitch servo torque is set at the maximum value and hold as much force as possible without slipping the servo. If the torque is set at the maximum and the system still does not function, check automatic trim wiring. See trouble shoot guide in back

The switch in the first slot of the controller is to switch trim motor direction, see above diagram.

Two small slots are control indication LEDs, see above.

## **AUTO TRIM TROUBLE SHOOTING.**

Does the Trim bar always show on the display with the Auto pilot programmer engaged?  
Does the Auto trim drive the trim motor with no pressure on the elevator?

### **AUTO PILOT PROGRAMMER TEST**

Disconnect Auto trim harness 25 pin connector.  
Insert test contact pin into pin location 3 (Trim Sense 2.5v no control surface load)  
Insert test pin contact into pin location 15 (Ground)  
Apply power to Autopilot system  
Engage Autopilot

Check for trim sense voltage at (pin 3) to ground (pin 15) should be 2.5 volts. This should be checking the voltage on the trim sense wire from the autopilot programmer.

If yes, continue Programmer test good.  
Reconnect Auto trim harness

### **AUTO TRIM MODULE TEST**

Disconnect Pitch servo harness 9 pin connector  
Insert test contact pin into pin location 9 of servo connector (Ground)  
Insert test contact pin into pin location 7 of servo connector (Trim Sense 2.5v)  
Apply power to Auto pilot system  
Engage Auto pilot

Check for trim sense voltage at (pin 7) to ground (pin 9) should be 2.5 volts. This should be checking the voltage on the trim sense wire from the Auto trim module.

If yes, continue Module test good.  
Reconnect Pitch servo harness

### **SERVO TRIM SENSE TEST**

Remove cover from Pitch servo 9 pin connector to access pin contacts.  
Connect volt meter to aircraft ground. (confirm good ground by check for resistance to pin 9 of servo connector). Must be 0 ohms.  
Connect volt meter to pin 7 of servo connector.  
Apply power to autopilot system  
Engage autopilot  
Test voltage at pin 7 of servo, Must be @ 2.5 with **no load** on elevator. Apply pressure to elevator in both directions. Should be able to vary voltage up or down according to amount of force applied. Voltage range 0-5 volts.  
If yes, continue Servo test good.  
Reassemble connector shell.

### **TRIM MOTOR CONTROL TEST**

Disconnect Auto Trim Module harness connector  
Insert test contact pin into pins 8 & 11  
Connect volt meter across pins, there should be aircraft voltage when trim system is actuated with pilot trim control. This voltage must be positive one direction and negative in the other. If a Relay Deck is installed in the Trim System it **MUST** be wire **BEFORE** the Auto Trim Module and Trim motor.

Reconnect Auto Trim Module harness  
Connect volt meter across Trim motor output pins 9 & 10

Engage auto pilot, there should be pulsing voltage when trim system is actuated with pressure on the elevator. This voltage must be positive one direction and negative in the other.

### **This concludes the trim system testing**



## **RETURN MERCHANDISE POLICY AND PROCEDURE**

Under no circumstances should products be returned to TruTrak without first obtaining a Return of Merchandise Authorization number (RMA #) from TruTrak. An RMA # may be obtained by contacting us at 866-878-8725.

Products that do not have an RMA # will not be processed.

Please include some form of documentation stating the reason for the return and describing any symptoms, failure modes, suspected causes of damage, diagnostics performed, data collected, etc.

Product(s) should be packaged in their original shipping containers. In lieu of this, they should be very carefully packaged in containers suitable to protect them during transit. Note that damage caused during shipping will not be repaired under warranty.

The outside of the box must be clearly marked with the RMA # issued by TruTrak and the RMA # must also be noted on the return documents.

Products will be returned to the customer at no charge via FedEx Ground or UPS Ground. If customer requests expedited shipping (2<sup>nd</sup> Day or Overnight) they will be charged the shipping cost and must supply a credit card number.

Send ALL return shipments to:

Trutrak Flight Systems, Inc.  
1500 South Old Missouri Road  
Springdale, AR 72764  
USA  
Attention: Returns Dept.  
RMA# \_\_\_\_\_

### **Warranty On TruTrak Flight Systems Products**

We here at TruTrak Flight Systems know how important it is to feel as though the customer is purchasing a product that the manufacturer is going to stand behind. For this reason we want offer more than the basic one year warranty that is standard to this industry. The warranty on all TruTrak products will be three years from the date of purchase. Abuse and misuse of a product are not covered under this warranty. Modification to a product may void the warranty, as well as carry a penalty when upgrading to another product. This three year warranty will be for all products except the Pictorial Turn & Bank, which will continue to have a warranty of one year from the date of purchase.

# Autotrim Dimensions

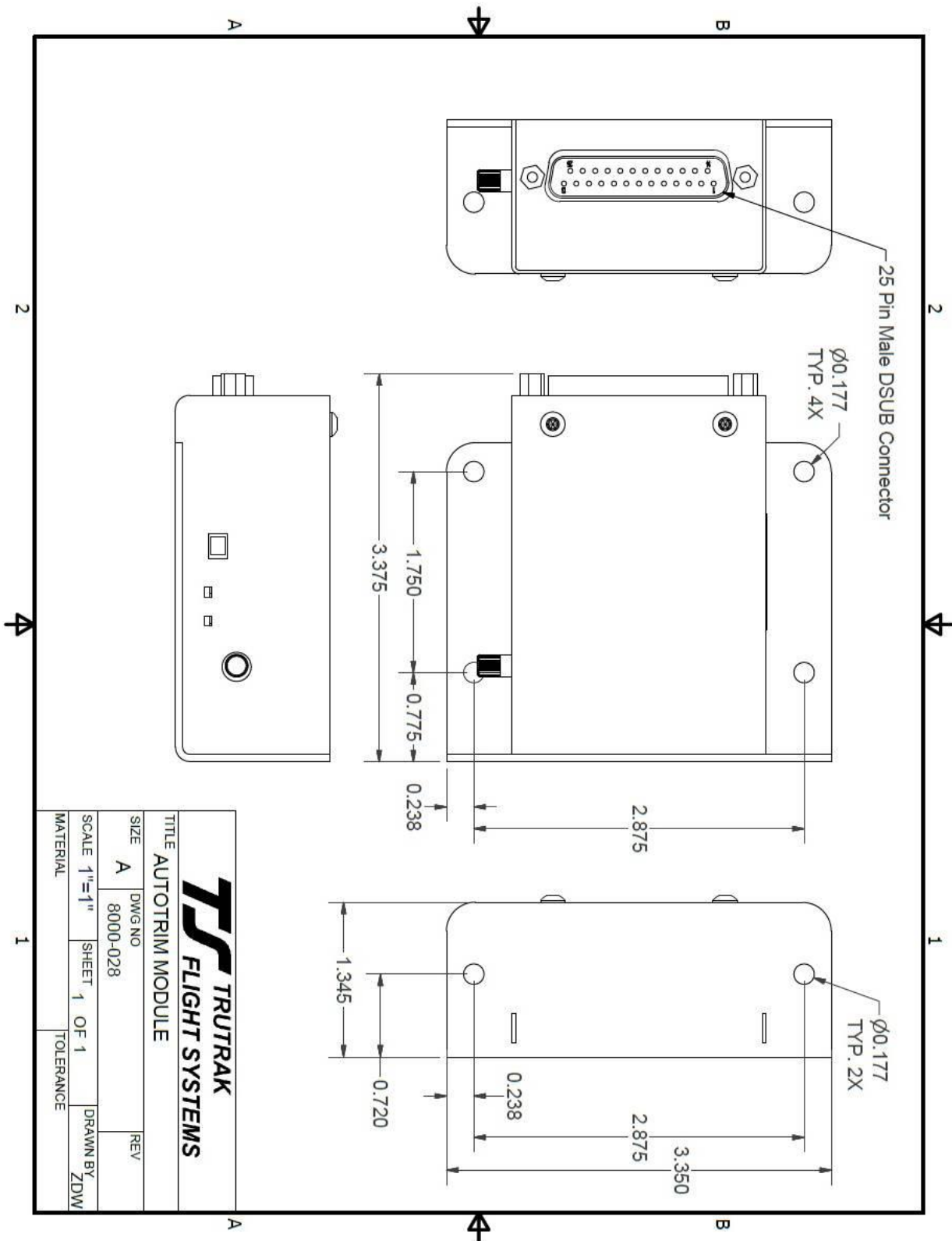

This page intentionally left blank

This page intentionally left blank

This page intentionally left blank



TRUTRAK FLIGHT SYSTEMS

**1500 S. Old Missouri Road  
Springdale, AR 72764**

POSTAL SERVICE ADDRESS

P.O. Box 189  
Springdale AR 72765-0189

**Ph: 479-751-0250 Fax: 479-751-3397**

**Toll free: 866-TRUTRAK**

**866-(878-8725)**

[www.trutrakap.com](http://www.trutrakap.com)