

Airpura

AIR PURIFIERS

F600-DLX

Formaldehydes - VOCs

Remove Formaldehyde and Volatile Organic Compounds

The Airpura F600-DLX Super Enhanced Chemical Abatement Unit offers you:

■ **26 lb super enhanced impregnated activated carbon bed**

Adsorbs airborne chemicals including formaldehyde, acid gasses and volatile organic compounds (VOCs)

■ **HEPA-barrier post filter**

Traps particles after the carbon bed

■ **560 CFM integrated fan / motor**

Largest CFM available in a portable unit

■ **Variable speed control**

Gives you flexible air flow options

■ **Proper contact times for effective filtration**

Correctly calibrated air flow / bed depth for efficient adsorption.

■ **Pressure sealed filter chamber**

Unique pressure seal on the filter chamber ensures all contaminants are filtered and non escape

■ **The Airpura Limited Warranty**

5 years parts 10 years labor

■ **Call our air quality experts**

For the solution to your air pollution problem

■ **Over 4000 chemicals can be removed**

Carbon blends are available to deal with over 4000 airborne chemicals including:

Formaldehyde	Hydrogen Sulfide	Hydrogen fluoride	Toulene
Ammonias	Mercury vapors	Hydrogen chloride	Napthene
Nitrous dioxide	Chlorine dioxide	Benzene	Pesticides
Nitrous trioxide	Hydrogen Bromide	Methylene Chloride	Chlorine
Monoethylamine	Sulfur dioxide	Radioactive Iodine	Mold Mycotoxins



The Airpura F600 DLX

Available in
White / Black / Cream

Filter Life

Carbon filters should be changed as needed in heavy applications and at least every 24 months in normal use.

HEPA Barrier filters should be changed every 12 months

Pre-filters can be vacuumed from the exterior of the unit and should be changed every 12 months depending on use

Protect Yourself with Airpura High Efficiency Air Purification

This filtration combination is not recommended for people with severe MCS

Airpura

AIR PURIFIERS

F600-DLX

Formaldehyde - VOCs

Technical Specifications

Odor, airborne chemical and VOC control

26 lbs super enhanced impregnated activated carbon 13" x 13" x 7.5"

Carbon bed

3" deep x 570 sq" surface

Air Flow 560 cfm

More cfm than any other portable unit available

Pre-filter

570 sq in x 1in

Post particle filter

306 sq in

Size

23" x 15"

Weight

49lbs total

Voltage Options

115 or 220 volts

Watts

120 on high
40 on low

Sound Level

28.1 db on low (at 6 feet)
62.3 db on high (560 cfm)
(Room level 25.1 db)

ETL Certified

Conforms to
CSA C22.2 no 113
ANSI / UL 507

Your Airpura Dealer

Filtration system

Cleanable pre-filter
Vacuum through grill and change every 12 months

26 lb

Super Enhanced
Impregnated Carbon filter
Contains

Potassium permanganate: 35%

Coconut shell carbon: 65%

3" deep super enhanced
impregnated carbon bed
ensures effective formadehyde
and VOC adsorption

HEPA-barrier filter

Traps particles after the carbon bed

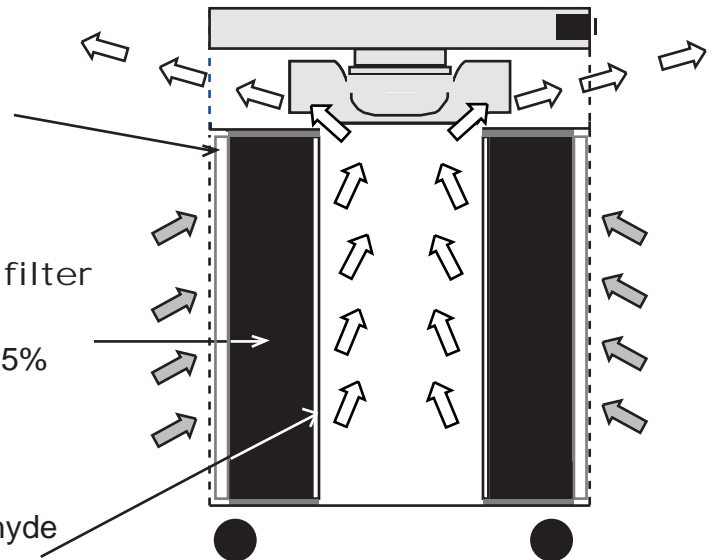

Specially designed to remove formaldehyde, specific airborne chemicals and VOCs

An effective approach to abating formaldehyde issues until the half life point occurs or the formaldehyde source is removed

Industrial capacity in a convenient format

The F600-DLX is a cost effective way to bring immediate relief from a formaldehyde or VOC problem and is a good investment for the future health of you and your family. After the initial problem is resolved you may wish to replace the special chemical filter for conventional particle and airborne chemical filter combination to continue enjoying the benefits of clean air in your home

Dwell time

For best results the correct dwell time of the pollutants over the enhanced impregnated carbon bed is vital. The 560 CFM impeller/motor combined with the variable speed control and unimpeded airflow of the Airpura 600 series allows you to set the airflow precisely and achieve the results you need.

Safe effective air filtration to alleviate formadehyde and VOC problems

This filtration combination is not recommended for people with severe MCS