WattMaster VAV

Control Systems

www.wattmaster.com

WMVAV Controller Technical Guide

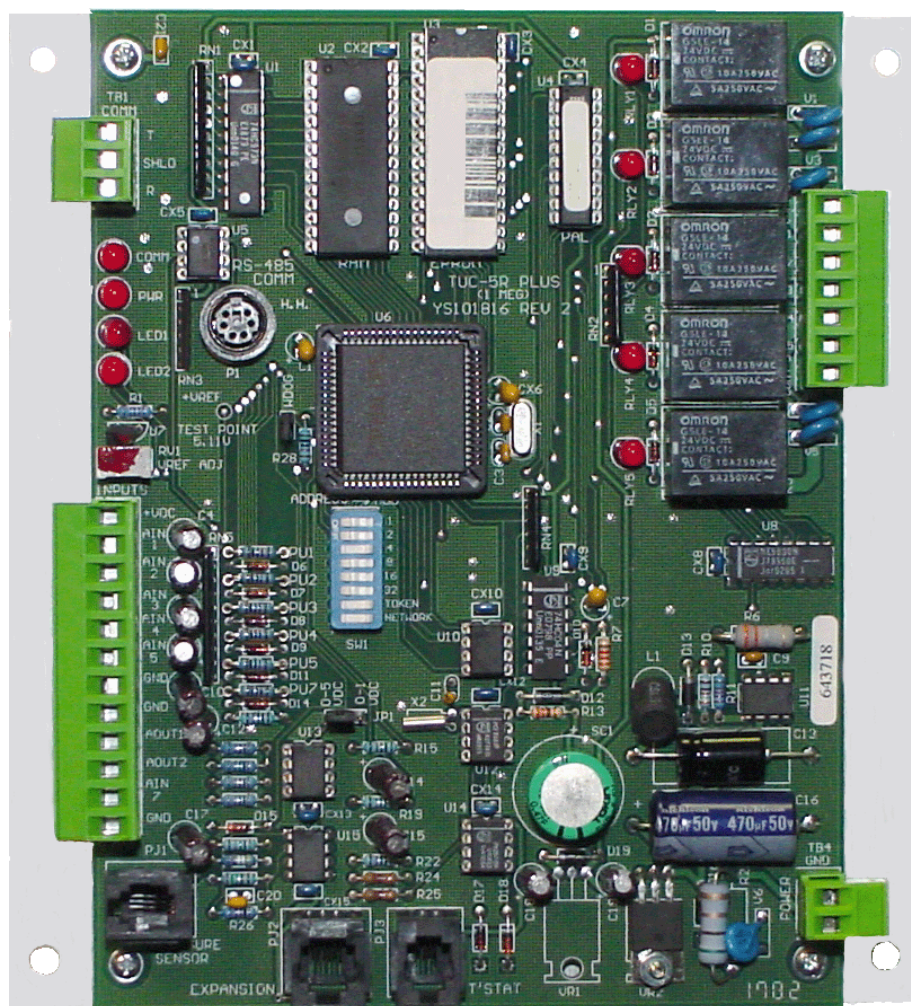

Table Of Contents

Controller Overview	3
Features	3
Controller Inputs and Outputs	5
General	5
WMVAV Controller Analog Inputs:	5
Expansion Board Analog Inputs	6
WMVAV Controller Analog Outputs	6
Expansion Board Analog Output	6
WMVAV Controller Relay Outputs	6
Expansion Board Relay Outputs	7
Expansion Board Binary Inputs	7
Controller Installation & Wiring	7
General	7
Controller Mounting	7
Important Wiring Considerations	7
Remote Forced Mode Settings	7
Expansion Board Installation & Wiring	9
Jumper Settings	9
Wiring Considerations	10
Wiring Details	11
Space Temperature Sensor	11
Supply & Return Temperature Sensor	11
Outside Air Temperature Sensor	12
Remote Occupied Contact	12
Humidity Sensor	13
Supply Fan VFD Signal	13
Relief Fan VFD Signal Wiring	14
Relief (Building) Pressure Sensor	14
CO2 Sensor	15
Supply Setpoint Reset	15
Start-up & Commissioning	16
Controller Addressing	16
Power Wiring	16
Initialization:	17
Programming The Controller	17
Sequence Of Operations	18
Initialization	18
WMVAV Configuration & Setup	18
Other Control Options	18
Scheduling	19
Occupied/Unoccupied Mode	20
Main Fan Control	20
HVAC Mode Calculation	20
Static Pressure & Fan VFD Control	24
Relief Pressure & VFD Control	24
Exhaust Fan Control	24
Hot Gas Re-Heat And Dehumidification Control (If Available)	24
Preheat Operation	25
Air to Air Heat Pump	25
Alarm Detection and Reporting	25
Force Modes or Overrides	26
Internal Trend Logging	26
VAV Box Compatibility	26
Troubleshooting	27
Using LED's To Verify Operation	27
Appendix	28

Controller Overview

Features

The WMVAV Controller Board is designed with 7 usable analog inputs, 2 analog outputs and 5 relay outputs. The controllers input and output capabilities can be expanded by use of either 2 slot or 4 slot expansion boards that plug into the WMVAV Controller by means of a modular cable. The WMVAV Controller can be configured for control of VAV Units (with or without VAVBOX Controllers), Constant Volume Units and Air to Air Heat Pump Units. Features include the following:

- Up to 8 Stages of Cooling (4 on board, 4 more with expansion board)
- Up to 8 Stages of Heating (4 on board, 4 more with expansion board)
- Selectable Control Sensor
- Fan Proving Interlock
- Wetbulb Control of Economizer Operation
- Accepts Remote Occupied Signal
- Relief Pressure Control
- De-Humidification Capable
- Full Economizer Control
- I.A.Q. Control with CO₂ Sensor Monitoring

- 7 Day, 2 Event per Day Scheduler Built In
- 14 Day Holiday Scheduler Built In
- Optimal Start Scheduling Built In
- Override from Occupied to Unoccupied Mode
- Internal Trend Logging
- Supply Air Reset Capability
- Accepts Remote HVAC Mode Selection Via Contact Closure On Expansion Input Board

Most HVAC unit control configurations can be configured with the standard WMVAV Controller. If the application requires more inputs and/or outputs, optional relay expansion boards are available from the factory to provide for additional analog, binary or digital inputs and outputs as required. These expansion boards are installed on either a 2 slot or 4 slot expansion base board that connects to the WMVAV Controller board via a modular cable connection.

The available expansion board configurations allow for 4 additional binary inputs, 4 additional analog inputs, 1 additional analog output, and up to 16 additional binary (relay) outputs. The various expansion boards connect to the expansion board base. Jumpers must be set according to the board type installed. Up to 4 Relay Output Expansion Boards can be installed on the expansion base board connected to the controller.

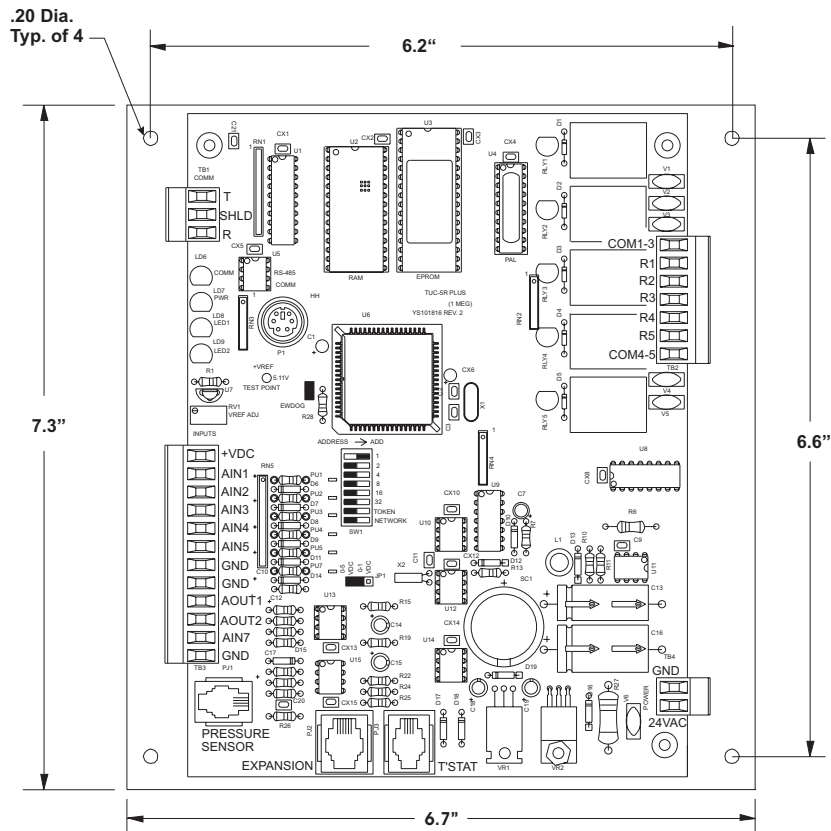

Figure 1: WMVAV Controller Dimensions

Controller Overview

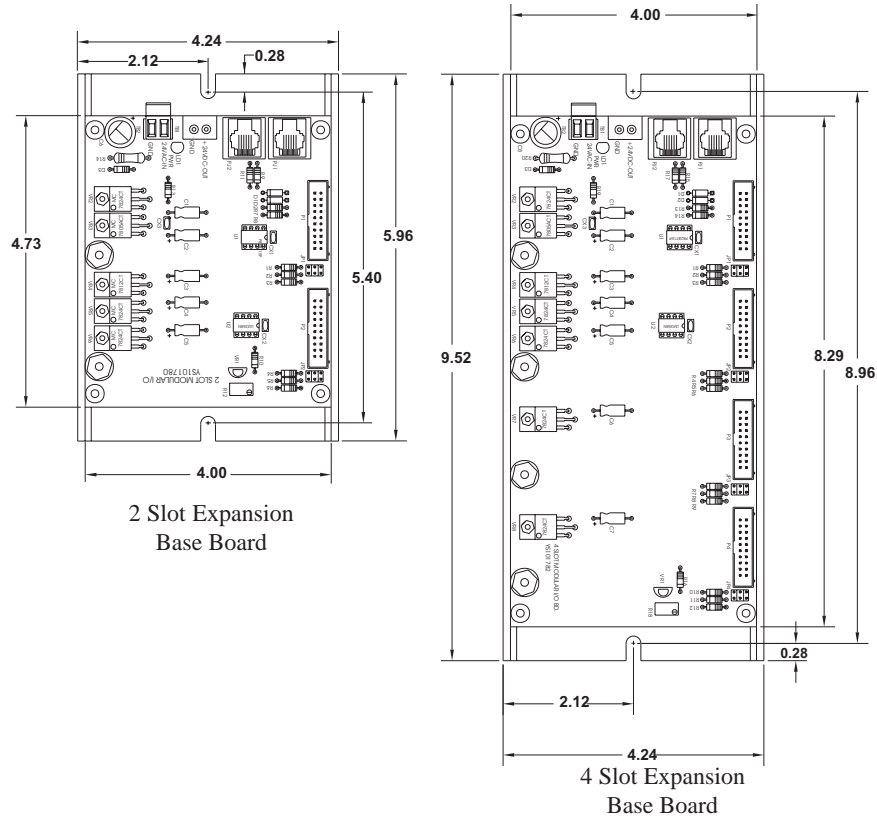

Figure 2: Expansion Base Boards Dimensions

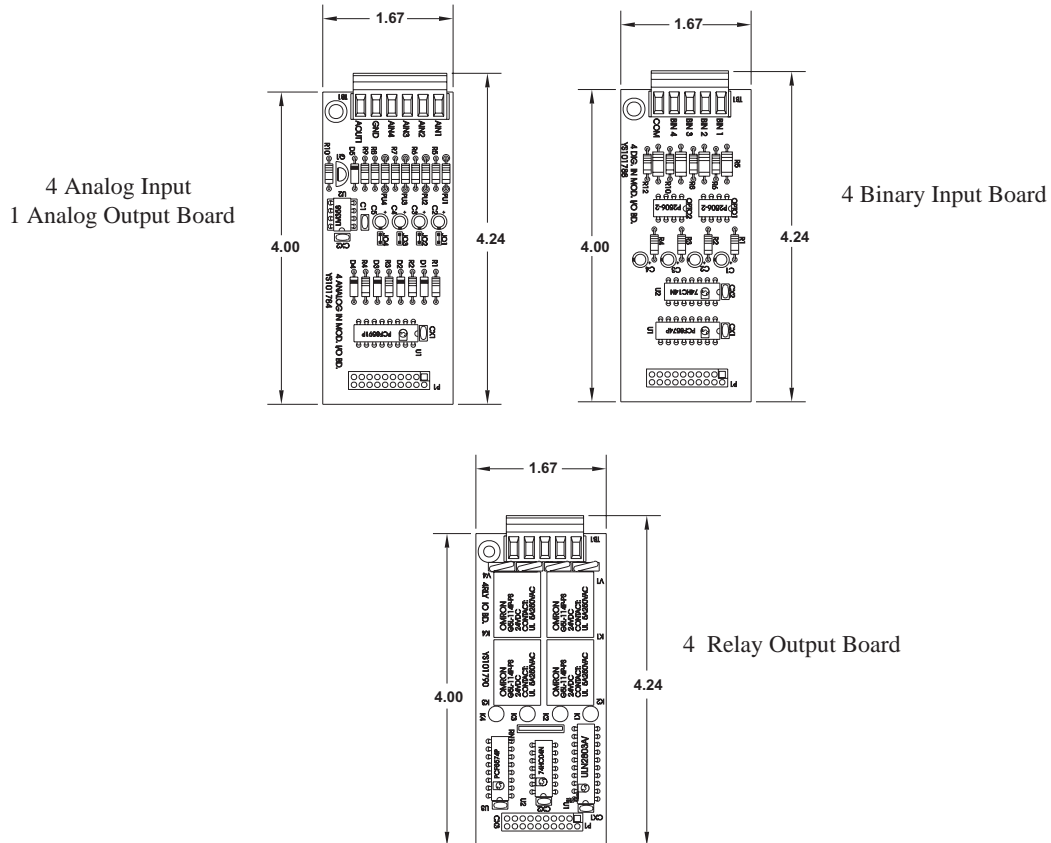

Figure 3: Expansion Boards Dimensions

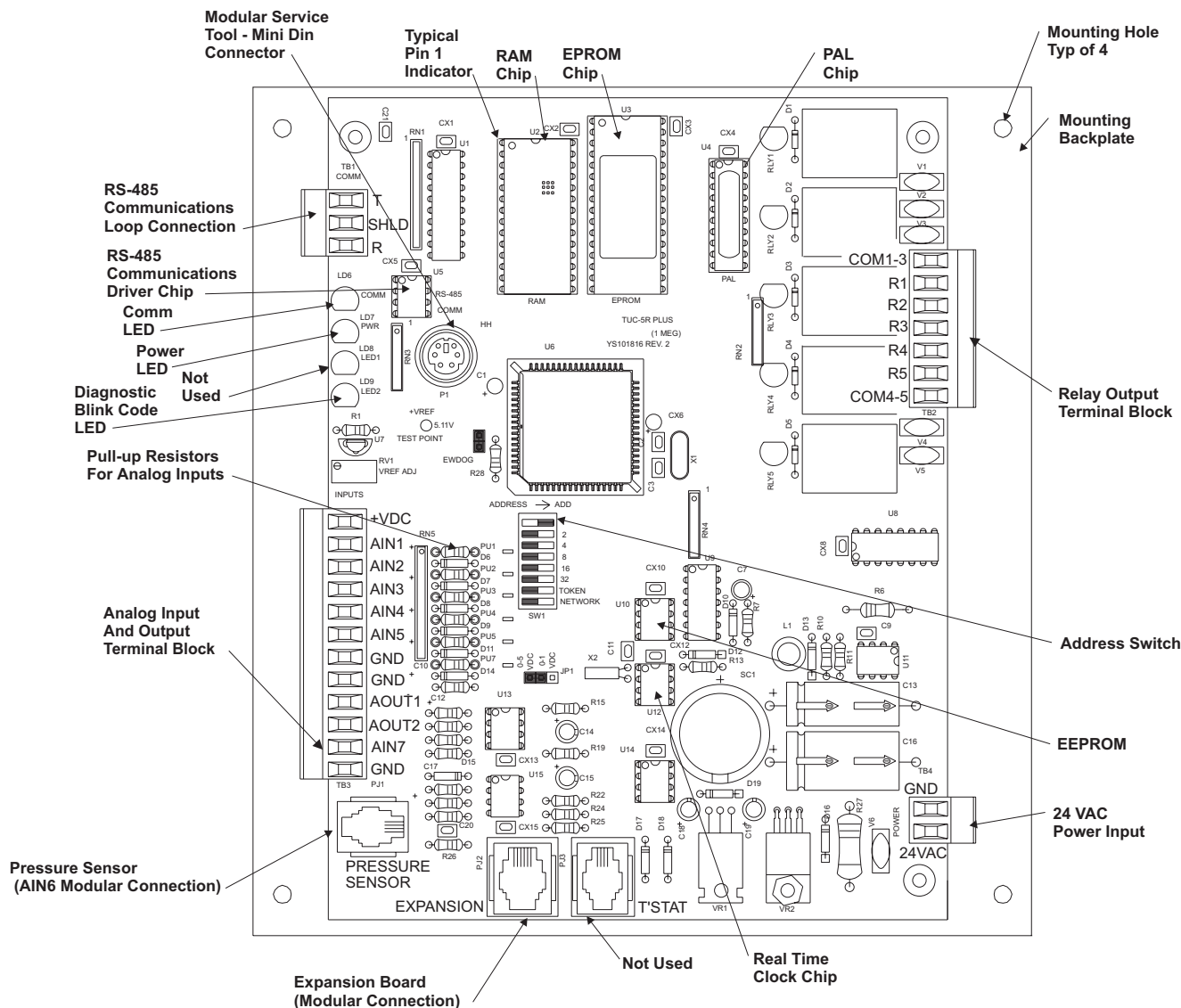

Figure 4: WMVAV Controller Component Locations

Controller Inputs and Outputs

General

The following inputs and outputs are available on the WMVAV controller and/or the various expansion boards that can be added to the main controller board expansion port. For component locations of the inputs on the WMVAV Controller see **Figure 4**. For wiring of inputs and outputs see **Figure 5** and **6**.

WMVAV Controller Analog Inputs:

Input #1: Space Temperature

The space temperature can be used for night setback control or it can be configured as the main control source instead of the default Supply Air Temperature. If the optional push-button override sensor is installed,

this input will detect user overrides from unoccupied back to occupied operation for a user adjustable amount of time. This sensor is not required if this is a cooling only air handler that doesn't require night setback operation. The space temperature can also be configured to reset the Discharge Air Temperature Setpoint.

Input #2: Supply Air Temperature

The supply air is the default control source. This temperature is maintained at the Supply Air Cooling Setpoint during occupied hours of operation and during the Cooling Mode. If the unit is in Warm-Up or Heating Mode, a separate Supply Air Heating Setpoint is maintained. The air handler must always have a supply sensor installed.

Controller Inputs and Outputs

Input #3: Return Air Temperature

The return air is used to initiate and cancel the morning warm-up period. This sensor can also be selected as the controlling temperature in place of the supply air or space temperature. If the return air is the controlling sensor, it can be configured for cooling only operation or it can also generate an occupied heating mode of operation. The Space Temperature Sensor must be installed for night setback operation. The Return air temperature cannot be used for night setback since air may stagnate in the return duct or plenum and may or may not reflect the actual temperature in the building or space being controlled by the air handler.

Input #4 - Outdoor Air Temperature

The outdoor air temperature is used to lockout heating or cooling to conserve energy at whatever temperature the user deems appropriate for each mode of operation. The outdoor air can also be used to provide low ambient protection in the building. If the outdoor air is below a low ambient setpoint, the Preheat Relay Output will be maintained during occupied operation and will not be allowed to stage off unless the main fan is turned off. The outdoor air temperature is also used as an economizer enable input.

Input #5 - Outdoor Air Humidity Or Remote Occupied Signal

Depending on how the user configures their system, this input can be used for an outdoor air humidity sensor that, combined with the outdoor air temperature, is used to calculate a Wetbulb Temperature for the purpose of Economizer Control. This input can also be configured to monitor a contact closure from another building automation system that indicates that the equipment should be operating in the occupied mode. If the remote occupied signal is being monitored, you must program all the internal schedules to be zero for both the start and stop times on every day of the week. If both an Outdoor Air Humidity Sensor and a Remote Occupied Signal Input are required, the Remote Occupied Signal Input should be connected to the 4 Analog Input Expansion Board terminal #2.

Input #6 - Static Pressure Sensor Input

This special phone jack input accepts a standard pressure transducer used to calculate the Duct Static Pressure. This static pressure reading is used to control the Fan VFD signal. If you have configured the air handler for Constant Volume operation, this sensor is optional. If it is installed it will not affect operation; it will be used as a status only reading.

Input #7 - Fan Proof of Flow Switch

A Proof of Flow Switch that provides a contact closure whenever the fan is operating correctly can be monitored on this input. If this contact opens while the fan is on, all heating and cooling is suspended. This is an optional item. If a switch is installed, the user must configure the WMVAV controller to utilize the signal. Input #7 can also be used to connect the slide adjust wiring when a room sensor with the slide adjust option is used.

Expansion Board Analog Inputs

Input #1 - Supply Setpoint Reset

This input can be configured to read a 0.0-5.0 or 0 – 10.0 VDC signal. via jumper settings on the expansion board. See Figure 6. The maximum setpoint is created by adding the reset limit to the Supply Air

Setpoint. The Supply Air Setpoint is proportionally reset from its minimum value at 0 VDC to its maximum value at full scale voltage.

Input #2 - Remote Occupied Contact

If you configured Input #5 on the WMVAV controller board as a humidity sensor, you can move the remote occupied contact closure to this input.

Input #3 - Carbon Dioxide

This sensor is required if you need to monitor Indoor Air Quality and modify the Economizer operation based on levels of CO₂ in the space or building you are monitoring.

Input #4 - Relief Pressure Sensor

This sensor is required only when you configure the WMVAV controller to control building / relief pressure. This sensor must provide a 0-5.0 VDC signal over a range of ± 0.25 " Water Gauge. Output control is provided in two manners. The first output control method uses the analog output on the Analog Input Expansion Board to provide a 0-10 VDC signal for control of VFD equipped relief / exhaust fans. As an alternative, you can configure one of the output relays as an exhaust fan output that will activate anytime the relief pressure is above the programmed setpoint. Remove pull up resistor PU4 and jumper J04 on expansion board.

Note: All temperature sensors must be Thermistor Type III which provide 77.0°F @ 10 K Ohms Resistance.

WMVAV Controller Analog Outputs

Output #1 - Economizer Signal

This 2.0 to 10.0 VDC signal is used to position the outside air dampers during economizer controls, or to maintain the dampers at a minimum position during occupied mode when the outdoor air temperature and / or humidity is not suitable for free cooling.

Output #2 - Supply Fan VFD Signal

This 0 to 10.0 VDC signal can be connected to a VFD fan speed controller or to proportional inlet vanes to control the Duct Static Pressure.

Expansion Board Analog Output

Output #1 - Relief Fan VFD Signal

Located on the 4 Analog Input 1 Analog Output Expansion Board. This 0 to 10.0 VDC signal can be connected to a Variable Frequency Drive fan speed controller to control the Building Static Pressure.

WMVAV Controller Relay Outputs

Relay #1 - Fan (Enable)

This is a non-configurable output.

Relay #2 - #5 Configurable Relays

These relays are located on the WMVAV Controller. For configuration order and options see the following information.

Expansion Board Relay Outputs

Relay #6 – #21 Configurable Relays

These relays are available by using Relay Expansion boards connected to the WMVAV controller. Relays can be configured in any order but we recommend that they be configured in the following order:

1. Heating (aux. heating) stages
2. Cooling (compressor) stages
3. Warm-up Mode command for Boxes
4. Reversing Valve for Air to Air Heat Pumps
5. Reheat Control for De-Humidification
6. Exhaust Fan
7. Pre-Heater for Low Ambient protection
8. Economizer Mode
9. Alarm
10. Override
11. Occupied Mode

You can have up to 8 stages of Heating (aux. heating) and 8 stages of Cooling (compressors). You may also utilize 1 relay output each on the WMVAV controller board for items 3 thru 11 above.

Expansion Board Binary Inputs

Input #1 - Humidistat Contact

This input is required for the dehumidification option.

Input #2 - Dirty Filter Contact Closure

This input is required for Filter Status Indication

Input #3 – Remote Forced Heat Mode

This input is used to allow another control system to force the unit into heating or vent modes as indicated. See Force Mode Setting Notes information below.

Input #4 – Remote Forced Cooling Mode

This input is used to allow another control system to force the unit into cooling or vent modes as indicated. See Remote Force Mode Setting Notes information that follows.

Remote Forced Mode Settings

Remote Forced Heating or Cooling Modes require that the user enter zero values for both the Heating and Cooling Setpoints. The Unit Controller will then look for contact closures on the Forced Cooling Mode and Forced Heating Mode inputs to operate the Air Handling Unit. If both the Forced Heating and Forced Cooling Modes are active the unit will operate in Vent Mode. The unit may also be operated in Vent Mode by providing a contact closure to the Remote Occupied Input.

Note: The Binary Inputs require wet contacts (24 VAC) to recognize an active input. If you provide dry contacts, the

Controller Installation & Wiring

General

Correct wiring of the WMVAV controller is the most important factor in the overall success of the controller installation process. The WattMaster VAV controls are purchased from WattMaster Controls for installation in the field. The information below gives guidelines and important considerations for field mounting and wiring.

Controller Mounting

It is important to mount the controller in a location that is free from extreme high or low temperatures, moisture dust and dirt. It is recommended that it be installed in the HVAC unit control panel. If this is not practical, it should be mounted in a separate control enclosure that is weathertight. Be careful not to damage the electronic components when mounting the controller. Remove the controller from its backplate. Mark the control enclosure base using the backplate as a template. Drill pilot holes in the enclosure base and secure the backplate to it using sheet metal screws. Do not allow metal shavings to fall onto the circuit board. Reattach the controller to the backplate.

Important Wiring Considerations

Please carefully read and apply the following information when wiring the WMVAV controller. See **Figure 5** for WMVAV controller wiring diagram.

1. All 24 VAC wiring must be connected so that all ground wires remain common. Failure to follow this procedure can result in damage to the controller and connected devices.

2. All wiring is to be in accordance with local and national electrical codes and specifications.
3. Minimum wire size for 24 VAC wiring should be 18 gauge.
4. Minimum wire size for all sensors should be 24 gauge. Some sensors require 2 conductor wire and some require 3 conductor.
5. Be sure that all wiring connections are properly inserted and tightened into the terminal blocks. Do not allow wire strands to stick out and touch adjoining terminals which could potentially cause a short circuit.
6. When communication wiring is to be used to interconnect WMVAV controllers together or to connect to other communication devices, all wiring must be minimum 18 gauge, 2 conductor, twisted pair with shield. WattMaster can supply communication wire that meets this specification and is color coded for the network or local loop. Please consult your WattMaster distributor for information. If desired, Belden #82760 or equivalent wire may also be used.
7. Before applying power to the WMVAV controller, be sure to recheck all wiring connections and terminations **thoroughly**.

Controller Installation & Wiring

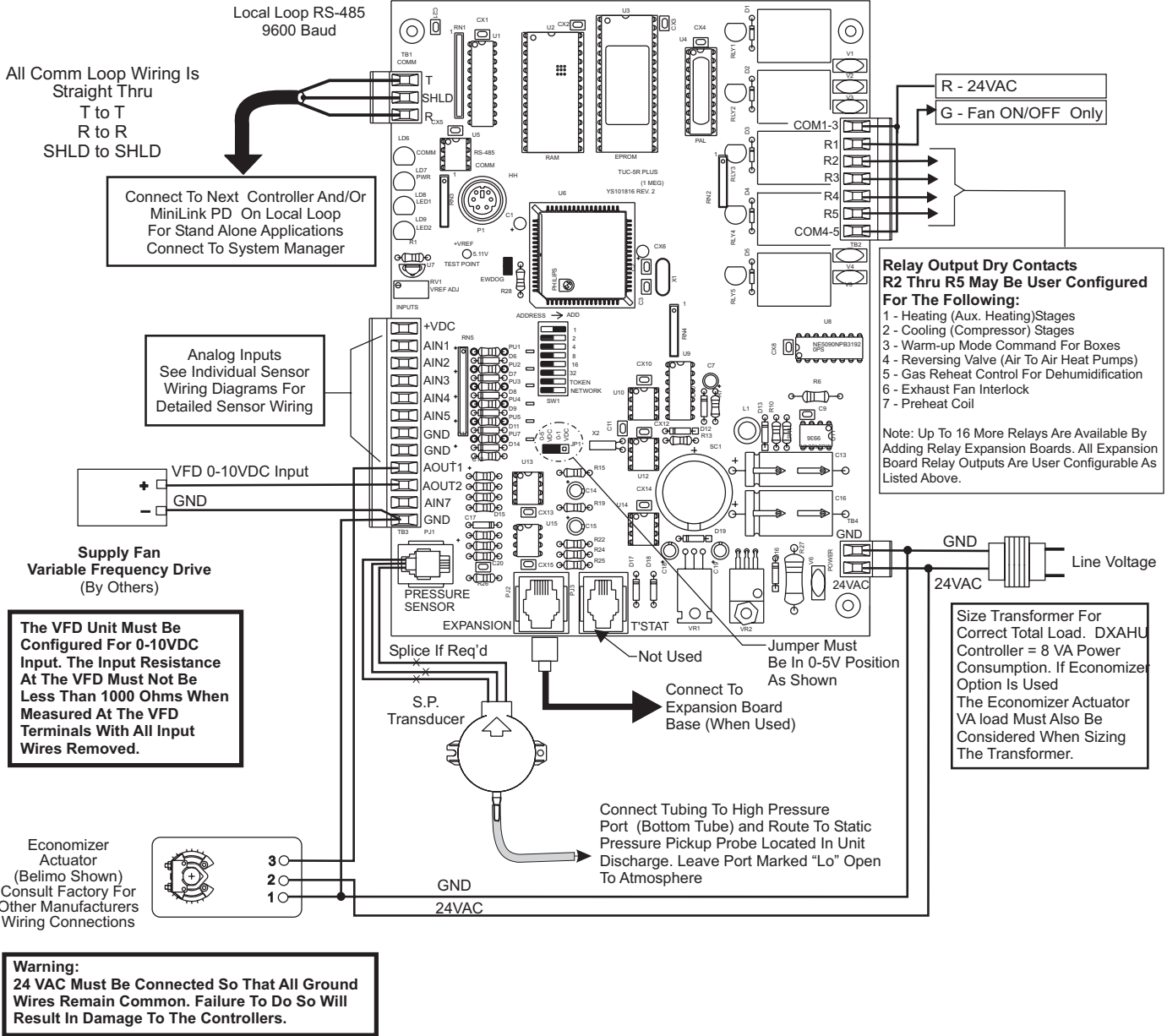

Figure 5: WMVAV Controller Wiring

Expansion Board Installation & Wiring

Jumper Settings

The expansion boards are connected to the WMVAV Controller with a modular cable. Up to 2 Expansion Base Boards can be populated with expansion boards to provide additional inputs and outputs. The expansion

boards can be placed on the expansion base board in any order, however, the jumpers on the Expansion Base Board must be set correctly for proper operation. See **Figure 6** for correct jumper settings and jumper locations.

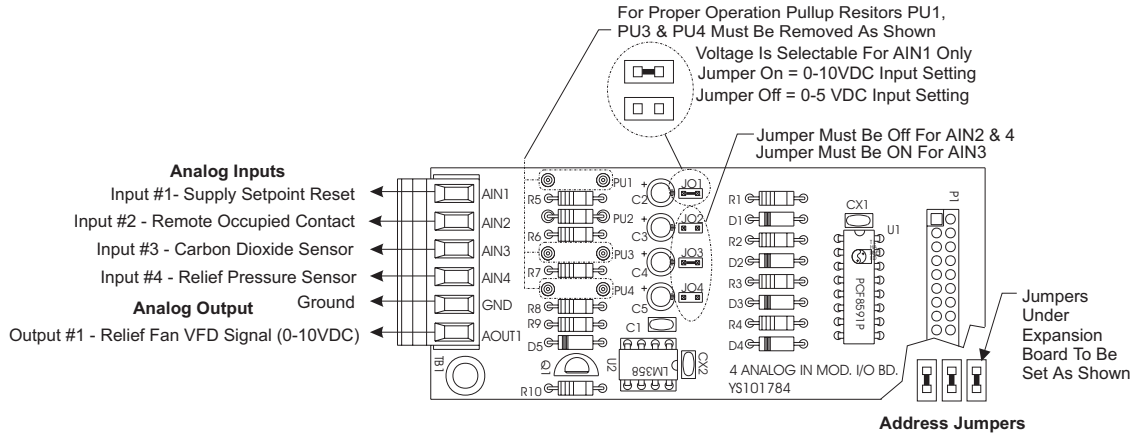

4 Analog Input - 1 Analog Output Expansion Board

Note: This Board Utilizes Wet Contact Inputs
See Wiring Info On Next Page.

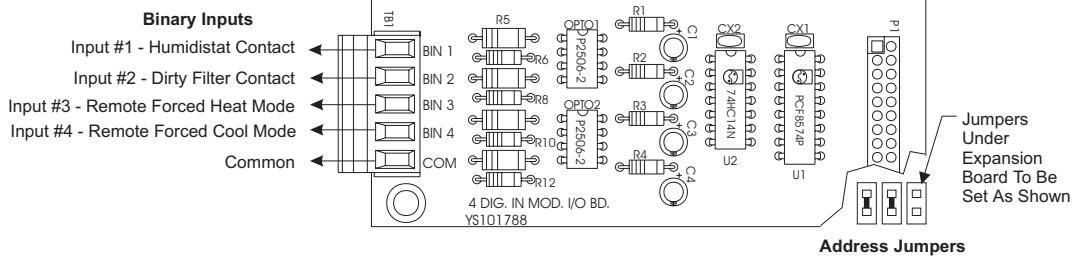

4 Binary Input Expansion Board

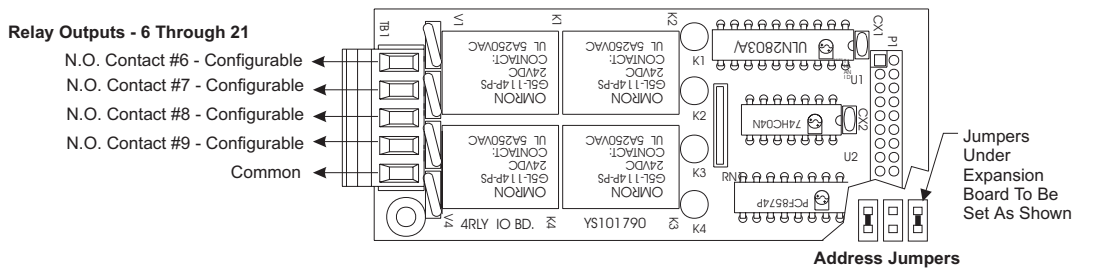

4 Relay Output Expansion Board

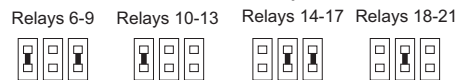

Figure 6: Expansion Board Jumper Settings

Expansion Board Installation & Wiring

Wiring Considerations

The expansion base boards must be connected to 24 VAC as shown in the wiring diagram below. As noted below, the power requirement for a two slot base board is 10 VA. A four slot base board requires 20 VA. Be

sure that the transformer used for powering the base boards meets these minimums. Also please note that when a binary input expansion board is used, its contacts must be wired as wet contacts (connected to 24 VAC) not dry contacts as used with the four relay expansion boards. See **Figure 7** for complete wiring details.

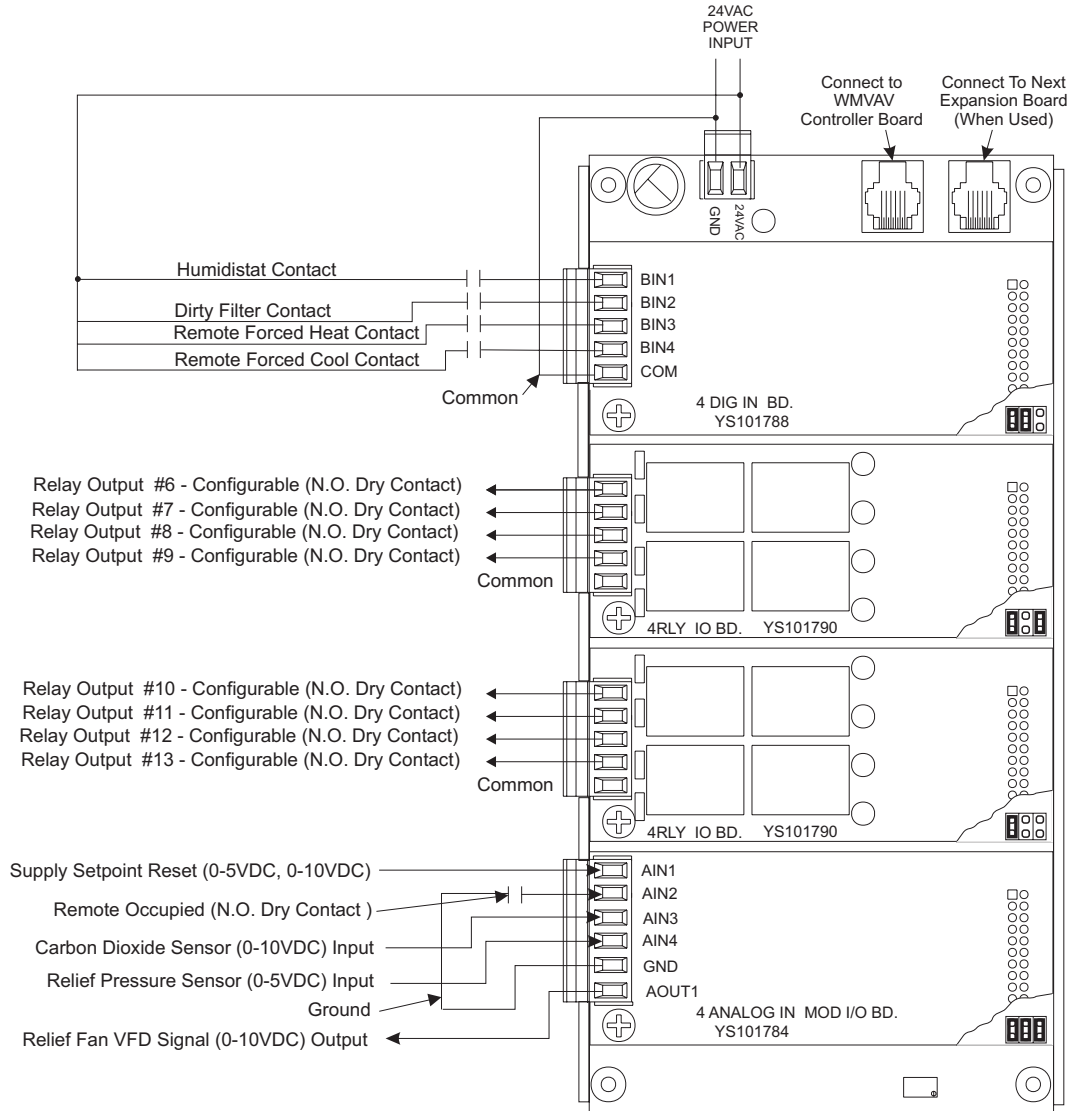

WARNING!!
 Observe Polarity! All boards must be wired with GND-to-GND and 24VAC-to-24VAC. Failure to observe polarity will result in damage to one or more of the boards. Expansion Boards must be wired in such a way that power to both the expansion boards and the controller are always powered together. Loss of power to the expansion board will cause the controller to become inoperative until power is restored to the expansion board.

Figure 7: Expansion Board Wiring

Wiring Details

Space Temperature Sensor

The Space Temperature Sensor is typically used for constant volume HVAC unit applications controlling one zone. The Space Temperature Sensor is a 10K Type III thermistor sensor. The Space Temperature Sensor should be mounted approximately 4 ft. above the floor in the

space that is to be controlled. The Space Temperature Sensor is available in a sensor only, sensor with override button, sensor with slide adjust and sensor with slide adjust and override configurations. If the Space Temperature Sensor with Slide Adjust option is to be used, the Fan Proof of Flow Switch cannot be used. See **Figure 8** for complete sensor wiring details.

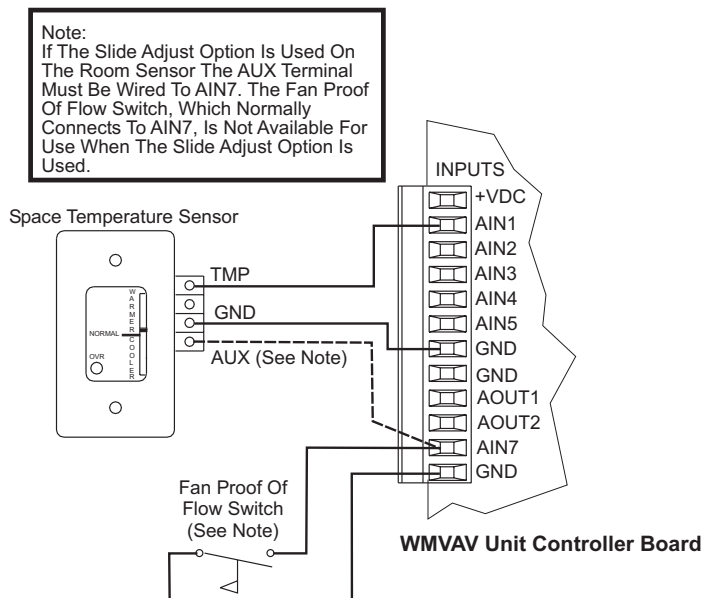

Figure 8: Space Temperature Sensor Wiring

Supply & Return Temperature Sensor

The Supply and Return Air Temperature Sensors must be wired as shown in the illustration below for proper operation. The Supply and Return Air Temperature Sensors are 10K Type III thermistor sensors. The Supply Air Temperature Sensor should be mounted in the unit discharge

plenum or in the supply air duct. The Return Air Temperature Sensor should be mounted in the return air duct. If the system has a bypass damper installed, be sure the return air sensor is located upstream of the bypass duct connection. See **Figure 9** for detailed wiring.

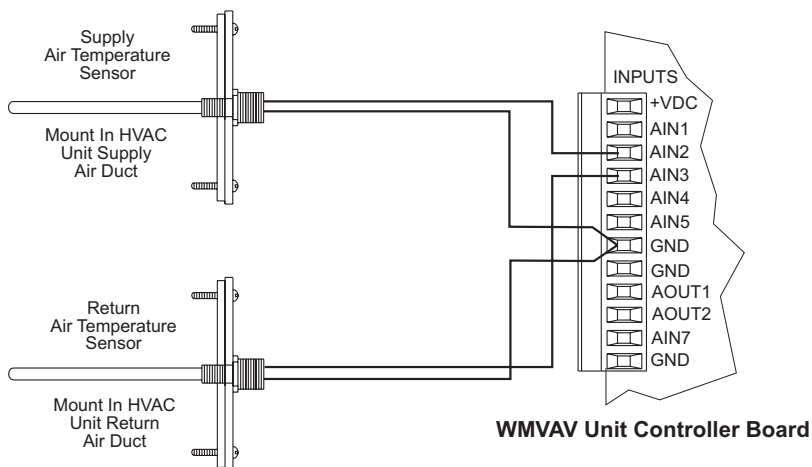

Figure 9: Supply & Return Temperature Sensor Wiring

Wiring Details

Outside Air Temperature Sensor

The Outside Air Sensor must be wired as shown in the illustration below for proper operation. The Outside Air Temperature Sensor is a 10K Type III thermistor sensor. The sensor should be mounted in the upright position as shown, in an area that is protected from the elements and direct sunlight. Be sure to make the wiring splices inside of the Outside Air Temperature Sensor weathertight enclosure. See **Figure 10** for detailed wiring.

Caution: Be sure to mount the Outside Air Sensor in an area that is not exposed to direct sunlight. A shaded area under the eave of the building or under the HVAC unit rainhood is normally a good location. If sensor is not located as specified, erroneous outside air temperature readings will result. Unused conduit opening(s) must have closure plugs installed and must be coated with sealing compound to provide raintight seal. Water can damage sensor!

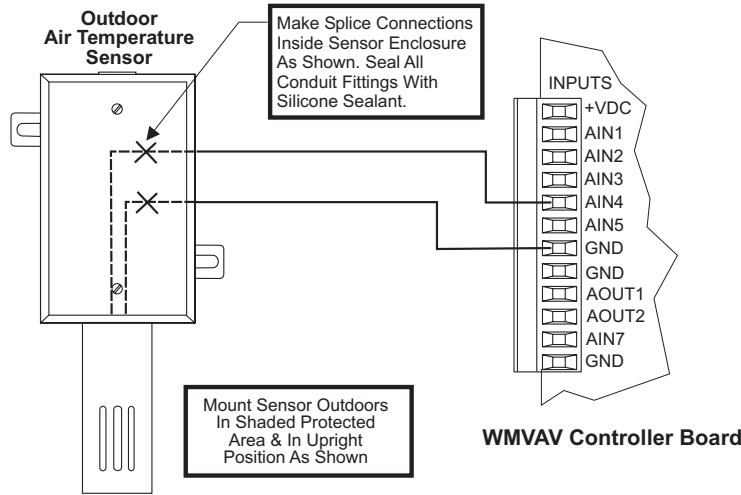

Figure 10: Outside Air Temperature Sensor Wiring

Remote Occupied Contact

A Remote Occupied contact closure supplied from another Building Automation System device can be used to enable Occupied and Unoccupied modes on the WMVAV controller. This relay contact must be a dry contact and be wired as shown below. If a Humidity Sensor is to be

used with your system, the Remote Occupied Contact must be wired to AIN2 of the 4 Analog Input 1 Analog Output Expansion Board as AIN5 on the WMVAV controller will then be used for the Humidity Sensor wiring. See **Figure 11** below for detailed wiring of the Remote Occupied Contact when wired to the WMVAV controller or the 4 Analog Input 1 Analog Output Expansion Board .

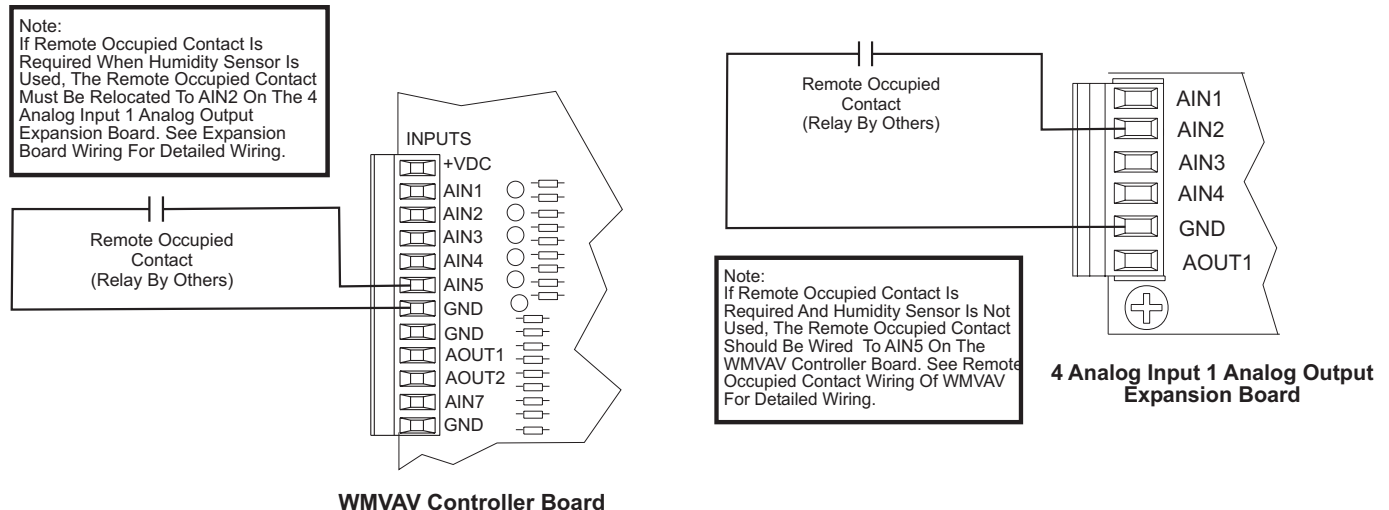

Figure 11: Remote Occupied Contact Wiring

Humidity Sensor

If you want to install a humidity sensor onto the WMVAV controller, it is important that you follow these instructions. There are 2 terminals labeled “H+” and “H-”. Terminal “H+” will connect to the connection labeled “+VDC” on the analog input block. See **Figure 12**. Terminal “H-” connects to the connection labeled “AIN 5” on the analog input block. Also the resistor labeled “PU5” needs to be removed. Lastly, a

supplied 250 Ohm, 1/4 Watt, 1% resistor needs to be installed between “AIN 5” and “GND”. See **Figure 12** for detailed wiring.

Warning: It is very important to be certain that all wiring is correct as shown in the wiring diagram below. Failure to observe the correct polarity will result in damage to the Humidity Sensor or controller.

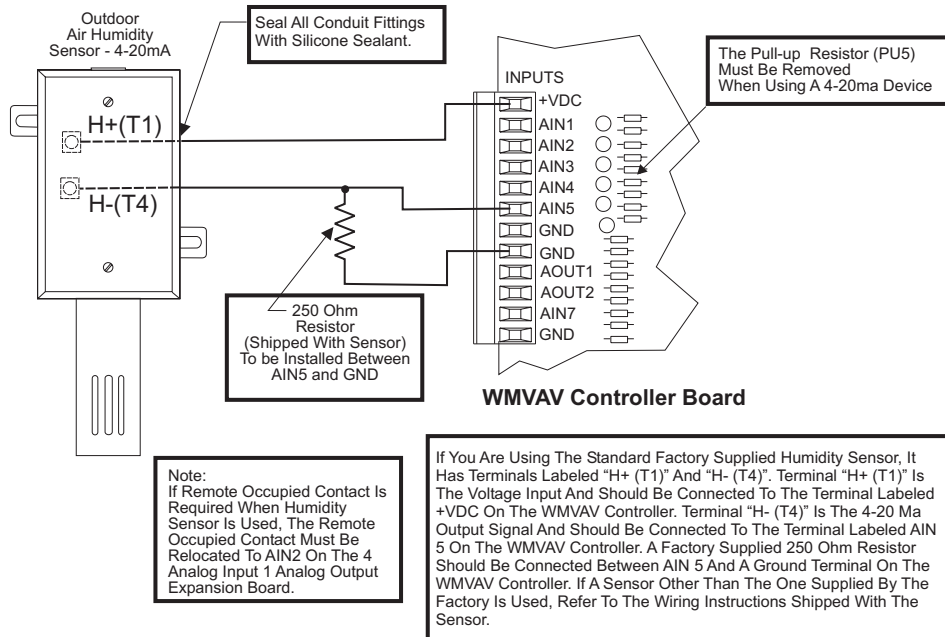

Figure 12: Humidity Sensor Wiring

Supply Fan VFD Signal

The Supply Fan VFD Signal is a 0-10 VDC output. This signal output can be connected to the Supply Fan Variable Frequency Drive to control duct static pressure utilizing the Discharge Pressure Sensor connected to the WMVAV controller board. A Discharge Pressure Sensor must be connected in order for the VFD to operate. See **Figure 13** below for detailed wiring.

Caution: Variable Frequency Drive units can cause large transient noise spikes which can cause interference to be propagated on other electronic equipment. Use shielded wire wherever possible and route all sensor/controller wiring away from the Variable Frequency Drive and the Air Handling Unit electrical wiring.

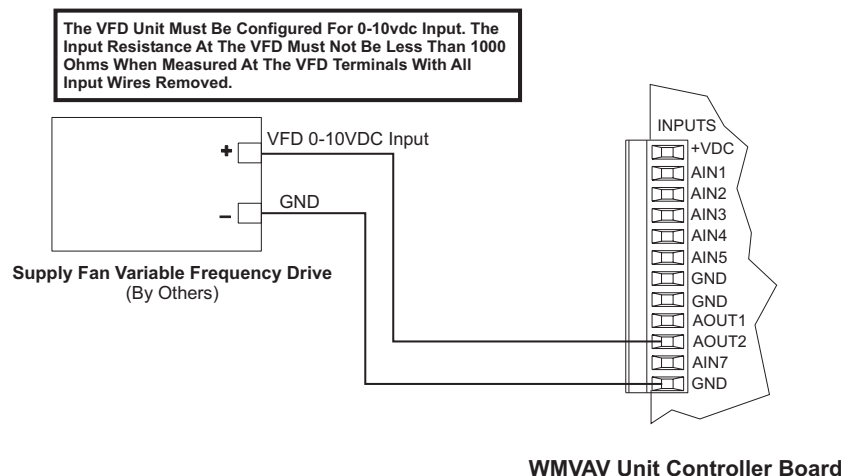

Figure 13: Supply Fan VFD Signal Wiring

Sensor Wiring Details

Relief Fan VFD Signal Wiring

The Relief Fan VFD Signal is a 0-10 VDC output. This signal output can be connected to a Relief Fan Variable Frequency Drive to control building static pressure utilizing the Relief Pressure Sensor connected to AIN4 on the Analog Input/Output Expansion board. A Relief (Building) Pressure Sensor must be connected in order for the VFD to operate. See **Figure 14** below for detailed wiring.

Caution:

Variable Frequency Drive units can cause large transient noise spikes which can cause interference to be propagated on other electronic equipment. Use shielded wire wherever possible and route all sensor/controller wiring away from the Variable Frequency Drive and the Air Handling Unit electrical wiring.

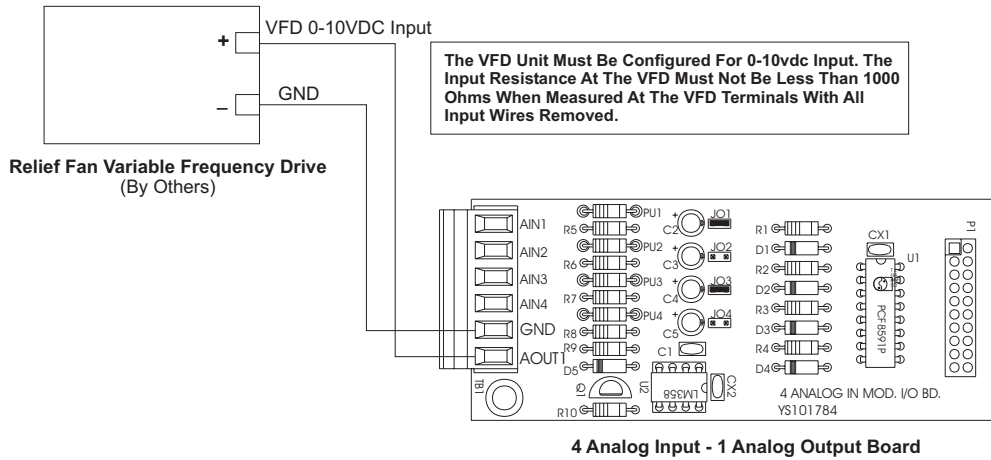

Figure 14: Relief Fan VFD Signal Wiring

Relief (Building) Pressure Sensor

The Relief Pressure Sensor must be wired as shown in the illustration below for proper operation. There are 2 terminals labeled “+” and “-”. Terminal “+” will connect to the connection labeled “+VDC” on the analog input block. See **Figure 15** below for detailed wiring.

Warning:

It is very important to be certain that all wiring is correct as shown in the wiring diagram below. Failure to observe the correct polarity will result in damage to the WMVAV Controller, Relief Pressure Sensor and the Expansion Board.

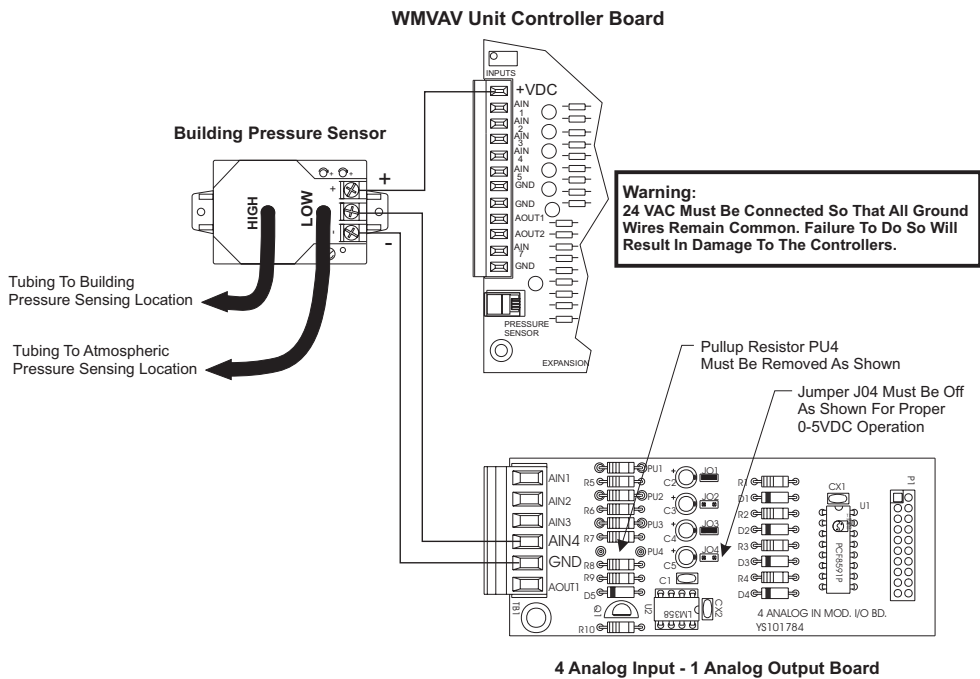

Figure 15: Relief Pressure Sensor Wiring

Sensor Wiring Details

CO₂ Sensor

The CO₂ Sensor must be wired as shown in the illustration below for proper operation. The 24 VAC power from the main board should be wired to the CO₂ Sensor terminal block as shown. The CO₂ Sensors 0-10 V output signal terminal is wired to terminal AIN3 on the Analog Input/Analog Output expansion board. The Signal Ground terminal from the sensor is wired to the GND terminal on the expansion board. See **Figure 16** below for detailed wiring.

Warning: It is extremely important to be certain that the CO₂ Sensors “AC/GND” terminal is connected to the GND terminal on the main WMVAV Controller board and the “AC+/DC+” terminal on the CO₂ Sensor is connected to the 24 VAC terminal on the WMVAV controller board as shown. Failure to observe the correct polarity will result in damage to the WMVAV Controller, CO₂ Sensor and the Expansion Board.

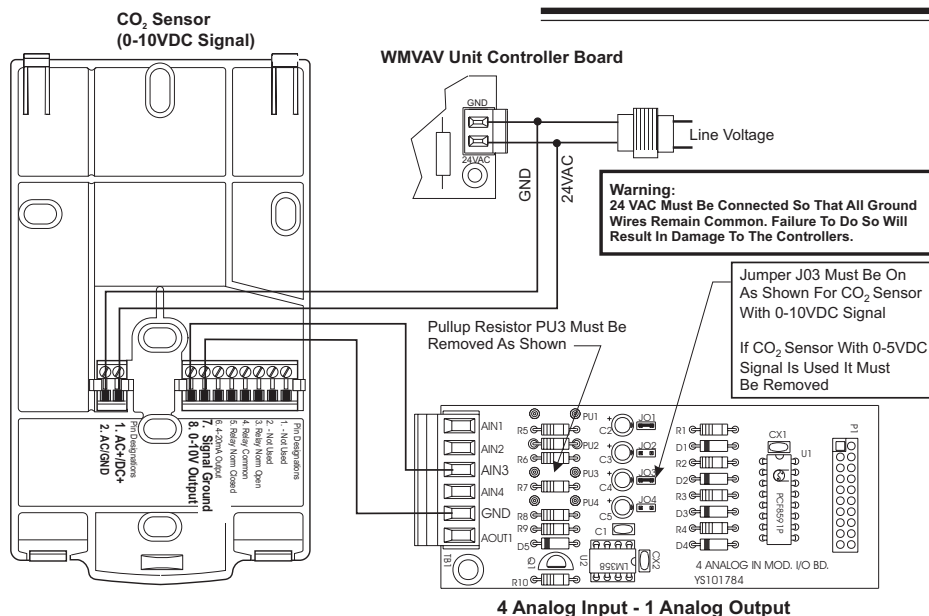

Figure 16: CO₂ Sensor Wiring

Supply Setpoint Reset

The Supply Setpoint Reset must be wired as shown in the illustration below for proper operation. The Supply Setpoint Reset is used to reset the AHU Controller Supply Air Temperature from a Separate control source. This signal can either be a 0-5 VDC or 0-10 VDC signal. The jumper must be either on for 0-10 VDC operation or be removed for 0-5 VDC operation.. See **Figure 17** below for detailed wiring.

Warning: The low side (-, GND) of the device supplying the 0-5 VDC or 0-10 VDC signal will be grounded at the WMVAV Controller. If your equipment requires isolation, an isolation device must be provided (by others). Failure to do so could result in damage to the WMVAV Controller, the Output Signal Device and the Expansion Board.

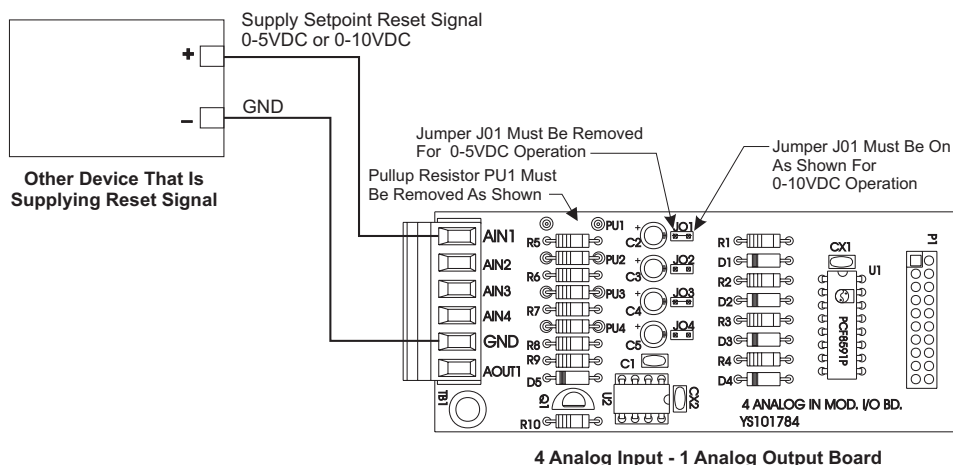

Figure 17: Supply Setpoint Reset Wiring

Start-up & Commissioning

In order to have a trouble free start-up it is important to follow a few simple procedures. Before applying power for the first time it is very important to correctly address the controller and run through a few simple checks.

Controller Addressing

All WMVAV controllers are equipped with address switches. If the WMVAV controller is to operate as a stand alone system (not connected to any other HVAC unit or VAVBOX controllers) the controller address switch should be set for address 1. When using the Modular Service Tool or System Manager to program and configure the WMVAV controller you would enter this address to communicate with the controller. When the system is to be connected to other HVAC unit controllers on a communication loop, each controller's address switch must be set with a unique address between 1 and 59. When the WMVAV controller will be used with VAVBOX controllers the WMVAV controller's address switch must be set as address 59, no exception. See Figure 18 for address switch setting information. For detailed information regarding communication wiring and connection for the WattMaster VAV networked systems, please see the WattMaster VAV Component and System Wiring - Technical Guide.

Power Wiring

One of the most important checks to make before powering up the system for the first time, is to confirm proper voltage and transformer sizing for the controller. Each WMVAV controller requires 10 VA of power delivered to it at 24 VAC. Each 2 slot expansion board requires 5 VA at 24 VAC and each 4 slot expansion board requires 10 VA at 24 VAC. You may use separate transformers for each device (preferred) or power several devices from a common transformer. If several devices are to be powered from a single transformer correct polarity must be followed.

Warning: Observe Polarity! All boards must be wired with GND-to-GND and 24 VAC-to-24 VAC. Failure to observe polarity will result in damage to one or more of the boards. Expansion Boards must be wired in such a way that power to both the expansion boards and the controller are always powered together. Loss of power to the expansion board will cause the controller to become inoperative until power is restored to the expansion board.

Check all wiring leads at the terminal block for tightness. Be sure that wire strands do not stick out and touch adjacent terminals. Confirm that all sensors required for your system are mounted in the appropriate lo-

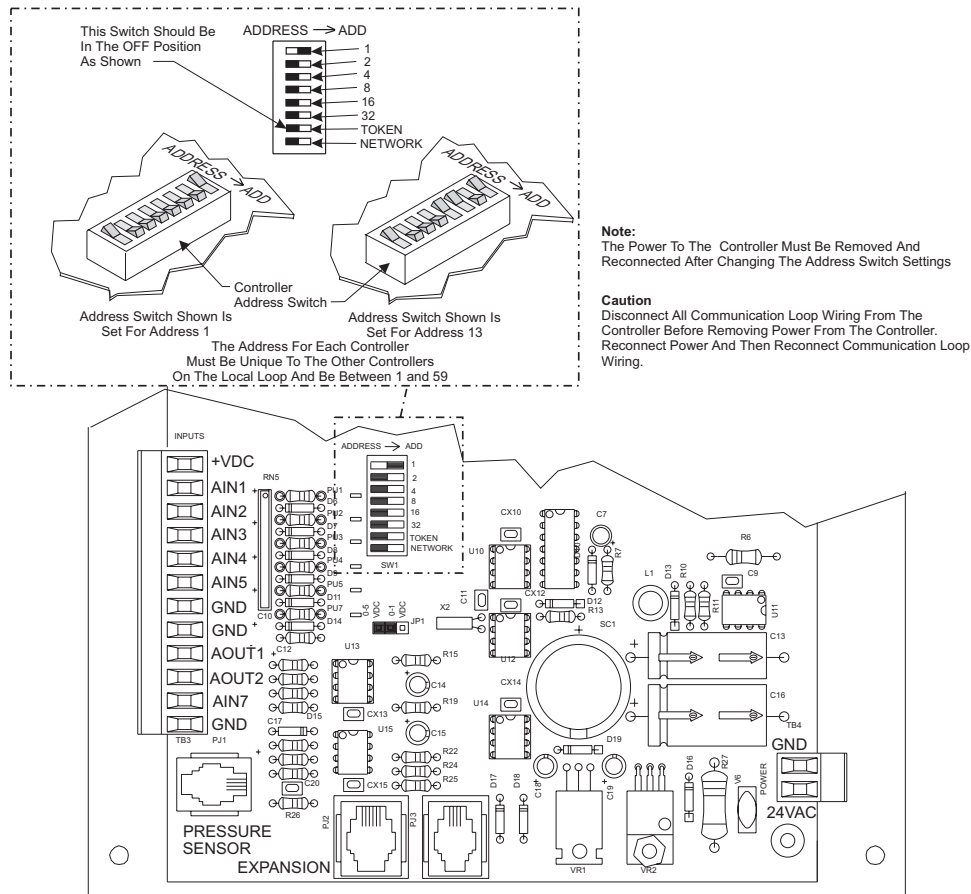

Figure 18: WMVAV Controller Address Switch Setting

cation and wired into the correct terminals on the WMVAV controller. Be sure any expansion boards connected to the WMVAV controller are also correctly wired just as you did for the WMVAV controller.

After all the above wiring checks are complete, apply power to the WMVAV controller and all expansion boards connected to it.

Initialization:

Upon applying power to the WMVAV controller the following should occur:

On system powerup a 30 second start-up delay is performed where all default setpoints are initialized, LED's are initialized and all outputs are turned off.

When power is first applied, LED2 is turned off for 5 seconds. At this time the LED will "blink" to indicate the setting of the address switch and then extinguish for another 5 seconds. The LED will now "blink" for a 30 second start-up delay to protect the fan and other components from short cycling during intermittent power conditions. If all inputs are operating correctly it will blink once every ten seconds.

The PWR LED should glow continuously. If this is a stand alone or interconnected system, The COMM LED should also glow continuously after its initial start-up routine. If this is a networked system, The

COMM LED should flicker approximately once every second to indicate communications are occurring. If the LEDs are behaving as indicated, proceed to the next step. If the LEDs fail to light or do not behave as indicated, please proceed to the troubleshooting section of this manual to diagnose and correct the problem before proceeding with the start-up process.

Programming The Controller

The next step is programming the controller for your specific requirements. In order to configure and program the WMVAV controller you must have a central operators interface or a personal computer with the Prism computer front end software installed. Two different central operators interfaces are available for programming of the WMVAV controller. You may use either the *Modular Service Tool* or the *Modular System Manager* to access the *status* and *setpoints* of any WMVAV controller on your communications loop. See the Modular Service Tool and System Manager Programming guide for WMVAV controller programming. If you are going to use a personal computer and the Prism computer front end software, please see the WattMaster Prism Programming Manual. No matter which operators interface you use, it is recommended that you proceed with the programming and setup of the controller in the order that follows:

- 1.) Configure The Controller For Your Application
- 2.) Program The Controller Setpoints.
- 3.) Program The Controller Operation Schedules.
- 4.) Set The Controller Current Time And Date.
- 5.) Review Controller Status Screens To Verify System Operation And Correct Controller Configuration

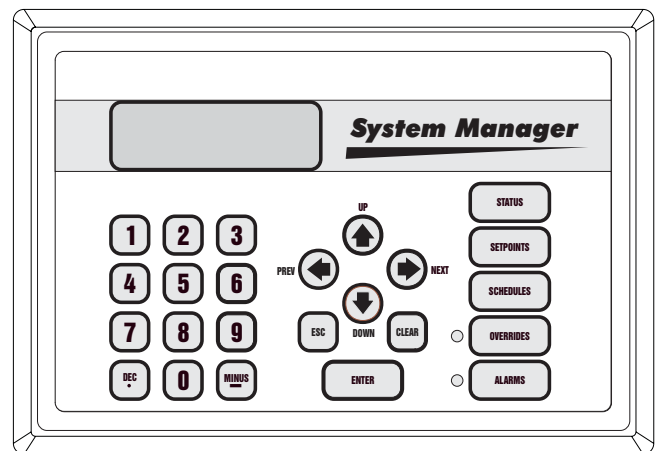
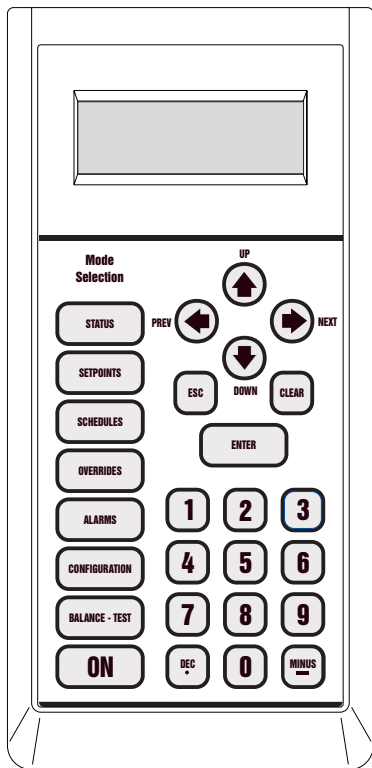

Figure 19: Operators Interfaces

Sequence Of Operations

Initialization

On system powerup a 30 second start-up delay is performed where all default setpoints are initialized, LED's are initialized and all outputs are turned off.

When power is first applied, LED2 is turned off for 5 seconds. At this time the LED will "blink" to indicate the setting of the address switch and then extinguish for another 5 seconds. The LED will now "blink" for a 30 second start-up delay to protect the fan and other components from short cycling during intermittent power conditions.

WMVAV Configuration & Setup

There are a few configuration selections available to the user, which can be used to tailor the software operation to match the mechanical equipment this controller is installed on.

Controlling Temperature Sensor

Supply Air Temperature (Default)

Select this option for cooling only units that are attempting to maintain a discharge air temperature instead of a space or return air temperature.

Return Air Temperature

The Return Air Temperature is used to activate the cooling, heating and vent mode of the HVAC Unit.

Space Temperature

A Space Temperature sensor can be used for constant volume applications only, to make the HVAC heating or cooling decision. It is only used in VAV applications if night setback operation is required or it is being used for Space Temperature reset.

Outdoor Air Temperature

If you want to generate occupied heating and cooling demands based on the Outdoor Air Temperature, select this option for the controlling sensor.

Signal From Remote Source

This option allows a separate WattMaster Controls device to provide a temperature reading that is used to make the HVAC mode decision. This temperature is used in place of any onboard sensors installed. If this mode is selected, you must have a separate controller installed on the RS-485 communications loop providing this information or the unit will revert to Supply Air Temperature control. During this mode of control, the temperature provided will be used as if it was a Space Temperature and all space temperature control sequences described in this manual will apply.

Supply Air Reset:

Voltage Signal From Remote BAS

The supply air temperature may be reset, upward to a user defined maximum on a signal from a Building Automation System. A 0-10 VDC signal is applied to AIN1 on the Analog Input Expansion board to control the reset value.

Outdoor Air Temperature

The supply air temperature may be reset, upward to a user defined maximum based on the outdoor air temperature. For example if the unit is in the heating mode, the supply air temperature can reset higher as the outdoor air temperature drops.

Space Temperature

The supply air temperature may be reset upward to a user defined maximum based on the space temperature. For example if the unit is in the heating mode, the supply air temperature can reset higher as the space temperature drops.

Fan VFD Signal

The supply air temperature may be reset upward to a user defined maximum based on the percentage of the fan VFD. For example if the unit is in the heating mode, the supply air temperature can reset higher as the fan VFD percentage increases.

Signal From a Separate Remote Unit (Local Analog Output)

For future use.

Return Air Temperature

The supply air temperature may be reset, up or down, between a user defined maximum and minimum, based on the return air temperature. For example if the unit is in the heating mode, the supply air temperature can reset higher as the return air temperature drops.

Relay Configuration:

Output Relay Configuration

Relays #2 thru 21 can be configured for the type of function that matches the WMVAV controller options. The relays can be configured for any of the following: Heating (Aux. Heating) Stages, Cooling (compressor) Stages, Warm-up mode command for boxes, Reversing Valve for Air to Air Heat Pumps, Gas Reheat Control for De-Humidification, Exhaust Fan and Pre-Heater for Low Ambient Protection.

Other Control Options

Proof Of Flow Switch

The WMVAV controller can monitor a Proof of Flow Switch contact closure on analog input #7. Anytime the fan is running this contact must be closed. If the contact does not close or remain closed no heating or cooling outputs can activate or remain active. If this option is selected, the loss of this signal can generate an alarm so that the user knows there is a problem that needs to be corrected. There is a built-in five second filter provided to prevent intermittent contact "bounce" from affecting the operation.

Humidity Sensor

If you require Wetbulb Temperature calculations to enable or disable the economizer, you must install an outdoor air humidity sensor on analog input #5 and inform the WMVAV Controller to use it for the wetbulb calculation. If you install the sensor but fail to configure for this mode, the calculation will not occur, as the unit doesn't know whether there is a humidity sensor or a remote occupied signal applied to that input. Only one configuration can be accepted for that input.

If you have several Air Handlers on a job-site and they are connected together via the RS-485 communications loop, you can select this option and configure the controller to broadcast Humidity and outdoor air temperature to all controllers on the network, instead of installing a Humidity sensor on every unit. This saves the user from having to install duplicate sensors on every air handler.

Remote Occupied Signal

If you have a separate source that will provide a dry contact closure to indicate the occupied mode, you can monitor this contact closure in place of a humidity sensor on analog input #5. If you are using the onboard humidity sensor, the remote occupied contact closure will be monitored on input #2 located on the analog input expansion board.

Relief Pressure Control

If you need to control building pressure, select this option. The controller will look for the pressure reading on input #4, located on the analog input expansion board and will send a control signal out on the analog output terminals on that same analog input expansion board. If you aren't controlling a relief fan VFD, or inlet vanes then you can configure one of the relays to activate as an exhaust fan output. Whenever the pressure is above the setpoint by an adjustable amount, the relay activates. When the pressure drops below the setpoint by the same amount, the relay deactivates. That means it can be used in conjunction with the VFD signal.

Supply Setpoint Reset

The cooling supply air setpoint can be reset from a Voltage Signal, Space Temperature, Outside Air Temperature, Fan VFD Signal, or from a Local Analog Signal provided by a separate WattMaster Controls device connected to the RS-485 communications loop.

De-Humidification

If your HVAC unit is configured as a Constant Volume unit, you can select this option to provide dehumidification control whenever the unit is operating in the vent mode and the dehumidification signal is active. See the Hot Gas Reheat & Dehumidification section for a complete description of this sequence.

Constant Volume Mode

You can configure your air handler to operate as a Constant Volume Unit. No duct static pressure control will occur. You can still connect a static pressure sensor and monitor the reading, but no control will occur. This mode can be selected for either the standard DX Air Handler or for the Air to Air Heat Pump mode.

Air To Air Heat Pump

Select this option whenever you are controlling an air to air heat pump that utilizes a reversing valve to enter the heating mode. The same compressor relays are staged in both modes. There are not separate heating and cooling relays.

Economizer Control

We prefer to have control of the economizer if your equipment is so equipped. If it is not, you can deselect the economizer control with this option. If you have third party economizer controller, proper cooling operation cannot be guaranteed since this WMVAV controller code uses the economizer as the true first stage of cooling. If you use the first compressor output to enable a separate economizer controller, you may encounter false mechanical cooling alarms.

CO₂ Sensor Installed

You can monitor CO₂ or you can use it to modify the economizer operation to gain an Indoor Air Quality (IAQ) mode of operation. Select this option in either case. If you use it to modify the economizer operation, the minimum damper position will be increased as the CO₂ level rises above an adjustable amount. The minimum will continue to increase with the level of CO₂ until the maximum (adjustable) damper position is reached. During normal economizer control, the maximum damper position is 100%. During IAQ mode the maximum amount of air brought in is limited to the maximum damper setpoint to prevent freezing conditions during the winter months.

Broadcast of Time Clock

This enables the WMVAV Controller to send its real time clock information to all controllers on the local loop. This must be used when connecting VAVBOX Controllers on the local loop, but can be used to synchronize clock time in all controllers on the local loop.

Broadcast Outdoor Air Temperature

This enables the WMVAV Controller to send its outdoor air temperature reading to all other controllers on the local loop. Specifically used when more than one WMVAV Controller is installed and only one Outside Air Sensor is installed.

Broadcast Supply Air to units on this loop

This enables the WMVAV Controller to send its supply air temperature reading to all controllers that do not have their own sensor on the local loop. This is standard for VAVBOX applications.

Broadcast WMVAV controller's Internal Schedule

This enables the WMVAV Controller to send its Occupied and Unoccupied status to the VAVBOX Controller on the local loop.

Broadcast Main Fan & Heat Status

This enables the WMVAV Controller to send status information on whether the Main Fan is running, or if it is in Heat Mode to the VAVBOX Controllers on the local loop. This enable is required when VAVBOX Controllers have heating stages or are fan-powered.

Broadcast Relative Humidity

This enables the WMVAV Controller to send its humidity reading to all other units that do not have their own humidity sensor. Specifically used when more than one air handler is on a single loop, and only one humidity sensor is used on a specific air handler on the local loop.

Scheduling

The WMVAV Controller has an internal battery backed up Real Time Clock (RTC) that allows the controller to keep the time and allows for scheduling. It can also broadcast the time to the VAVBOX Controllers if the option is chosen.

The WMVAV Controller has an internal 7 day schedule with 2 start-stop events per day. You can also have 1 holiday schedule with 2 start-stop events. This holiday schedule can be used for 14 different holiday periods.

One thing to be noted is that you cannot view the current time when you are viewing the WMVAV Controller with the Modular Service Tool or the System Manager. You can however change the time on the WMVAV

Sequence Of Operations

Controller through the Modular Service Tool or the System Manager. If there is any doubt on the current time, reenter the time and date and it will change the controller to match what you enter. If you want the feature of viewing the current time the WMVAV Controller is using, you must install a Personal Computer and the PRISM computer front end software.

The internal scheduling in the WMVAV Controller also includes a “self-teaching” optimal start routine that can be activated by entering a value greater than 1.0 for the Soak Multiplier setpoint. The optimal start function can only be used if your WMVAV Controller has an attached Space Sensor and it is being used as the controlling sensor, or you are receiving a signal from another WattMaster Controls device for the express purpose of utilizing the optimal start. No adjustments other than the Soak Multiplier are required from the user as the WMVAV Controller monitors how long it takes to reach the target temperature each day and adjusts the starting time accordingly. That means the first day you operate your HVAC unit it will not be able to optimally start because it does not have a “history” of previous starts and their results. After the first day, the WMVAV Controller will begin adjusting the start time and after six normally scheduled starts have occurred, the routine will have gathered enough data to provide an accurate pre-start based on the “learned” conditions. This is an ongoing learning process of the six previous starts, so the unit automatically adjusts for the changing seasons. If you don’t need this feature but you are using the space sensor as the controlling sensor, you can set the Soak Multiplier to zero to eliminate the optimal start routines.

Occupied/Unoccupied Mode

The WMVAV controller can utilize one of three methods for determining the Occupied Mode of Operation. An internal Week Schedule, which supports up to two start/stop events per day, is available. The unit can be configured to monitor for a contact closure from some other source. Or, the unit can be configured to monitor the communications loop for an external scheduling device if several WMVAV controllers are present and they all need to follow the same schedule. *If the contact closure is to be used, it is necessary to set all the internal week schedules to ‘0’ so that the internal schedule always commands the unoccupied mode.*

In any case, the WMVAV controller can still monitor the optional push-button override signal from the space temperature input and revert back to occupied mode for a programmed amount of time.

If you are using the internal week schedule mode, an optimal start calculation is available. See the Scheduling section of this manual for more information on the Optimal Start feature.

Push-button Override Operation

During unoccupied hours, the user can force the WMVAV controller back to occupied operation by pressing the override button for a period of time less than 3 seconds. This initiates the override or resets the override timer back to zero during unoccupied hours of operation.

During Override operations, the user can cancel the override by pressing the override button for a period of time between 3 seconds and 10 seconds. This restores the normal unoccupied operation.

If the override button is held for more than 10 seconds, it causes a Bad Sensor Failure Alarm. This is due to the fact that the override button actually shorts the Space Temperature sensor input to ground. If this

input is shorted to ground or left “floating” with no sensor detected for more than 10 seconds, it is considered a sensor failure if the WMVAV controller is configured for Space Temperature control.

You can still use the space sensor input for an override command even when a space sensor is not connected. Simply provide a momentary push-button connected between Input #1 and the Ground terminal on the same connector. Follow the above procedure for initiating overrides, even on Supply Air Controlled cooling only air handling units.

Main Fan Control

Anytime the fan is requested to start, a timer is checked to make sure it has been off at least 1 minute. This 1 minute delay is to protect against rapid cycling on and off of the fan. Once the 1 minute has been satisfied, the fan relay is activated and all other outputs are verified to be in the off condition for a period of between 1 to 2 minutes. This short period of operating alone serves to purge the stagnant air from the duct before any heating or cooling occurs.

HVAC Mode Calculation

There are 5 possible HVAC Modes of Operation. They are:

Vent Mode

Cooling Mode

Heating Mode

Warm-Up Mode

Dehumidification Mode

Off Mode

The process of determining each mode is discussed below, but the actual operation of each mode is in a later section of this manual.

Vent Mode

The controlling temperature is within setpoint limits and no heating or cooling is required to maintain the temperature.

Cooling Mode

The controlling temperature is above the Cooling Setpoint by the user adjustable Deadband amount or this is a Supply Air Controlled Cooling Only WMVAV controller in the Occupied Mode.

Heating Mode

The Space Temperature or Return Air Temperature is the controlling temperature when the temperature is below the Heating Setpoint by the user adjustable Deadband amount.

Warm-up Mode

Can be initiated by a cold Return Air Temperature when the controller switches from Unoccupied to Occupied Mode.

Dehumidification Mode

If the humidity level rises above the humidistat setpoint when the HVAC unit is in Vent Mode it will be switched to Dehumidification Mode.

Off Mode

If the schedule has set the Unoccupied Mode and no heating or cooling demands are keeping the system on, the WMVAV controller switches to the Off Mode.

Remote Control of HVAC Mode

The Vent Mode and Heating and Cooling modes can be determined by a remote Building Automation System (BAS) if you set both of the heating and cooling setpoints to zero. This forces the controller to monitor for contact closures on the Binary Input Expansion board. If used in conjunction with the Remote Occupied contact closure, one or both of the operating decisions can be made by a separate BAS. If this mode of operation has been selected by setting the setpoints to zero, then the controller sets the Vent mode when both contacts are either open or closed. (Both in the same state) If input #3 is activated, the WMVAV controller enters the heating mode. If input #4 is activated the WMVAV controller enters the cooling mode. It is up to the BAS to make sure it doesn't cycle these inputs on and off rapidly, which would cause the WMVAV controller to operate erratically. Once the mode has been set, normal heating or cooling operations occur and all other user adjusted setpoints, such as the supply air setpoint are used in the actual control of the equipment.

Note: The following operations describe the control provided when the unit is configured as a VAV or Constant Volume Air Handler. If you configured for Air to Air Heat Pump operation, see that section of this manual for a description of how each of these modes operates.

Vent Mode Operation

This mode only applies to the Occupied Mode of operation. If the equipment is in the Unoccupied Mode, then a lack of heating or cooling demand would generate the **Off Mode**.

Note: During Vent Mode, all cooling stages are deactivated and the economizer dampers are maintained at a minimum position to provide fresh air into the building. The Static Pressure is still maintained by the Fan VFD signal since the Fan is still operating in this mode.

Cooling Mode Operation

If the space temperature sensor is used for control, this mode can also be generated during unoccupied hours via the Night Setup Offset applied to the occupied Cooling Setpoint. If the Supply Air or Return Air control the temperature, this mode is only generated during occupied hours of operation or override periods.

The Mechanical Cooling will be disabled if the Outdoor Air Temperature is below the Cooling Lockout Setpoint by 1°F. This gives a 2°F hysteresis around the Cooling Lockout Setpoint to prevent unwanted cycling in and out of mechanical cooling mode

If the outdoor air temperature disables the mechanical cooling while it is currently operating, the mechanical cooling will simply stage off if all staging and run times are satisfied.

If the Economizer has been enabled for operation, it is used as the first stage of cooling and then the mechanical cooling is activated if necessary. See the Economizer Operation section for a more detailed operating sequence. This section applies more to the mechanical cooling operation.

One of four sensors or the Remote BAS option can be configured as the Controlling Temperature Sensor. The four sensors are Space Temperature, Supply Air Temperature, Outdoor Air Temperature or Return Air Temperature. The Supply Air Temperature is the default control sensor. Whichever sensor is selected, the mechanical cooling is still staged in the same manner described below.

No matter which sensor is in control or if the BAS sets the mode, the Supply Air Temperature is always controlled to the Supply Air Setpoints. The Space/Return air Cooling Setpoint is not used by the WMVAV controller if the Supply Air is the controlling sensor or the Remote BAS is setting the mode.

Compressor Staging

When in the Cooling Mode of operation the compressors will stage on and off to maintain the Supply Air Temperature. The method that is used to accomplish this is explained in the following paragraphs.

All staging is based on a Heating/Cooling Supply Control Deadband value that is entered by the user. This value is used to determine the number of stages that will be activated as the temperature rises or falls within this deadband range.

The value is applied equally above and below the Supply Air Cooling Setpoint to stage compressors on and off.

Staging Up Example:

You have selected a 2°F Heating/Cooling Supply Control Deadband and a supply air setpoint of 55°F. This means that when the Supply Air Temperature rises above 57°F (2°F deadband above setpoint) the first stage of cooling would be initiated. Additional stages of cooling would be initiated based on the Minimum Off Time Setpoint and the Staging Up Delay Setpoint. Information regarding these setpoints follows after this example.

In addition to the staging sequence just outlined, there are timing requirements to protect the compressors and to enhance the temperature control.

There are two timing requirements for each compressor stage that must be satisfied before they can be activated. These are:

Minimum Off Time: A compressor cannot be activated unless it has been off for this amount of time.

Staging Up Delay: On a cooling demand call, all stages of cooling are enabled to start based on the Heating/Cooling Supply Control Deadband that has been set. The staging up delay period prevents all the enabled compressors from starting at once by requiring this period of time to elapse between each stage of compressor before it can be activated. This allows fine tuning of the operation by activating a stage and waiting for this amount of time to see if any additional stages are still required. If the supply temperature drops within the deadband range no additional compressors will be activated because you are within the specified temperature range with the current number of active compressors.

Sequence Of Operations

Staging Down Example:

You have selected a 2°F Heating/Cooling Supply Control Deadband and a supply air setpoint of 55°F. This means that when the Supply Air Temperature falls below 53°F (2°F deadband below setpoint) the last stage of cooling would be deactivated. Additional stages of cooling would be deactivated based on the Minimum Off Time Setpoint and the Staging Down Delay Setpoint. Information regarding these setpoints follows after this example.

In addition to the staging sequence just outlined, there are timing requirements to protect the compressors and to enhance the temperature control.

There are two timing requirements for each compressor stage that must be satisfied before they can be deactivated. These are:

Minimum Run Time: A compressor cannot be deactivated unless it has been on for this amount of time.

Staging Down Delay: This value determines how rapidly compressors can be staged off if the Supply Air Temperature is falling below the Heating/Cooling Supply Control Deadband. This prevents all compressors from cutting off at the same time if there is a rapid drop in temperature. On a decrease in cooling demand, stages of cooling are deactivated based on the Heating/Cooling Supply Control Deadband that has been set. The staging down delay period prevents all the enabled compressors from shutting off at the same time by requiring this period of time to elapse between each compressor stage before it can be deactivated. This allows fine tuning of the operation by deactivating a stage and waiting for this amount of time to see if any additional stages need to be deactivated. If the supply temperature rises within the deadband range no additional compressors will be deactivated because you are within the specified temperature range with the current number of active compressors.

If the supply temperature ever drops below the Supply Lo Cutoff Temperature Setpoint, all stages will be immediately deactivated to prevent freezing and all timing requirements will be ignored. The minimum off time will need to be satisfied before compressors can begin staging on again, once the supply air has risen back to a level that requires mechanical cooling stages.

Economizer Operation

This section assumes you have configured your air handler to control the outside air dampers in an economizer mode of operation.

If the Cooling Mode has been activated, as described under the Cooling Mode Operation section, the economizer is used as the first stage of cooling. If the outdoor air temperature and, optionally, the humidity are low enough, the system provides free cooling by opening the outside air dampers.

If the economizer is not enabled to provide cooling, it will still maintain the minimum position programmed by the user to provide minimum fresh air into the building.

As mentioned above, the WMVAV controller can monitor an outdoor air humidity sensor and combine that reading with the outdoor air temperature reading to create a Wetbulb Temperature. If this wetbulb temperature is not available, just the outdoor air temperature will be used. Whenever temperature is available, it must be below the economizer enable

setpoint by 1°F to enable the economizer during the cooling mode of operation. When the temperature rises 1°F above the enable setpoint the economizer will be disabled and return to minimum position.

As soon as the cooling mode is started, the economizer will calculate a starting damper position based on the outdoor air temperature and the distance of the supply air temperature from the supply setpoint. After it moves to this initial setpoint, further adjustments will be made in small increments to “fine tune” the damper position to maintain the supply setpoint. If the economizer reaches 90% open and the supply air is still too warm, the mechanical cooling will be enabled to operate to provide additional “stages” of cooling. Once a mechanical cooling stage has been activated, the economizer will remain full open until the mechanical cooling stages off or the outdoor air / wetbulb temperature causes the economizer to be disabled.

The supply air temperature must be above the supply setpoint by the user adjustable amount before the mechanical cooling can be activated. That means that if the supply is brought to within that defined window, the unit will consider the supply air satisfied and will not waste energy bringing on additional cooling.

If you have configured the WMVAV controller to monitor and control Carbon Dioxide levels, the economizer operation will be modified as follows:

1. The Maximum amount the economizer can open is determined by a user adjustable setpoint. Normally, the economizer can modulate full open to bring the supply air under control.
2. The Minimum position the economizer can close down to is reset higher as the level of CO₂ increases above the Maximum CO₂ Level programmed by the user. When the CO₂ level has increased the full amount above setpoint, set by the user, the economizer will be held to its maximum position and not allowed to open any further. The CO₂ level may not be decreasing but this provides protection against freezing conditions when it is cold outside.

Heating Mode Operation - Staged Heating

When in the Heating Mode of operation the electric or gas staged heat will stage on and off to maintain the Supply Air Temperature. The method that is used to accomplish this is explained in the following paragraphs.

As with the Cooling Mode operation, all staging is based on a Heating/Cooling Supply Control Deadband value that is entered by the user. This value is used to determine the number of stages that will be activated as the temperature rises or falls within this deadband range.

The value is applied equally above and below the Supply Air Heating Setpoint to activate or deactivate stages of heating.

Staging Up Example:

You have selected a 2°F Heating/Cooling Supply Control Deadband and a supply air setpoint of 120°F. This means that when the Supply Air Temperature drops below 118°F (2°F deadband below setpoint) the first stage of heating would be initiated. Additional stages of heating would be initiated based on the Minimum Off Time Setpoint and the

Staging Up Delay Setpoint. Information regarding these setpoints follows after this example.

In addition to the staging sequence just outlined, there are timing requirements to protect the heating equipment and to enhance the temperature control.

There are two timing requirements for each heating stage that must be satisfied before they can be activated. These are:

Minimum Off Time: A heating stage cannot be activated unless it has been off for this amount of time.

Staging Up Delay: On a heating demand call, all stages of heating are enabled to start based on the Heating/Cooling Supply Control Deadband that has been set. The staging up delay period prevents all the enabled stages from starting at once by requiring this period of time to elapse between each stage of heat before it can be activated. This allows fine tuning of the operation by activating a stage and waiting for this amount of time to see if any additional stages are still required. If the supply temperature rises into the deadband range no additional stages of heat will be activated because you are within the specified temperature range with the current number of active stages.

Staging Down Example:

You have selected a 2°F Heating/Cooling Supply Control Deadband and a supply air setpoint of 120°F. This means that when the Supply Air Temperature rises above 122°F (2°F deadband below setpoint) the last stage of heating would be deactivated. Additional stages of heating would be deactivated based on the Minimum Off Time Setpoint and the Staging Down Delay Setpoint. Information regarding these setpoints follows after this example.

In addition to the staging sequence just outlined, there are timing requirements to protect the heating equipment and to enhance the temperature control.

There are two timing requirements for each heating stage that must be satisfied before they can be deactivated. These are:

Minimum Run Time: A stage cannot be deactivated unless it has been on for this amount of time.

Staging Down Delay: This value determines how rapidly heating stages can be staged off if the supply temperature is rising above the Heating/Cooling Supply Control Deadband. It prevents all enabled stages from cutting off at the same time if there is a rapid rise in temperature. On a decrease in heating demand, stages of heating are deactivated based on the Heating/Cooling Supply Control Deadband that has been set. The staging down delay period prevents all the enabled stages from being deactivated at once by requiring this period of time to elapse between each stage of heating before it can be deactivated. This allows fine tuning of the operation by deactivating a stage and waiting for this amount of time to see if any additional stages need to be deactivated. If the supply temperature falls within the deadband range no additional heat stages will be deactivated because you are within the specified temperature range with the current number of active stages.

If the supply temperature ever rises above the Supply Hi Cutoff Temperature Setpoint, all stages will be immediately cutoff to prevent overheating and all timing requirements will be ignored. The minimum off time will need to be satisfied before heating stages can begin staging on again, once the supply air has dropped back to a level that requires additional heating.

Warm-up Mode Operation

Whenever the WMVAV controller is returned to occupied operation (not override mode!), the unit compares the return air temperature to a target warm-up temperature. If the return air is below this setpoint, the warm-up mode is initiated. This mode remains in effect until the return rises above the target temperature or a user adjusted time period elapses. Warm-up mode is not initiated by push-button overrides or unoccupied heating demands.

Once the warm-up mode has been terminated, it cannot resume until the unit has been through a subsequent unoccupied mode. (Only one warm-up mode per day!)

If you have stand alone VAV boxes that need to be forced wide open during the warm-up mode, you can configure one of the relay outputs to be used during this mode. If the warm-up mode is active, the relay is activated. This relay then becomes the force open command for all boxes to which it is wired.

Dehumidification Mode Operation

If your HVAC unit is configured for constant volume operation and has a humidistat installed, the unit will switch to dehumidification mode when the humidity in the space rises above the humidistat setpoint while the unit is in the Vent Mode of operation. Dehumidification will not initiate if the HVAC unit is in Heating or Cooling modes.

When the HVAC unit is switched to Dehumidification Mode by the closure of the humidistat contact, half of all available cooling stages will be enabled and staged to bring the humidity level below the humidistat setpoint. When in dehumidification mode the Supply Air Setpoint is reset to a value calculated to be halfway between the Space Heating and Space Cooling Setpoints in order to try to deliver neutral air to the space. An additional stage of cooling may be initiated in order to maintain the Supply Air Temperature at the new calculated Supply Air Temperature Setpoint. If the unit is equipped and configured for reheat the reheat will also be cycled to try to maintain the Supply Air Temperature at the new calculated Supply Air Temperature Setpoint.

If your HVAC unit is configured for VAV operation, dehumidification is available in cooling mode. With VAV units when you are using Supply Air Control, Supply Air Reset capabilities are removed during the dehumidification mode. Reheat is not available for VAV systems.

Off Mode of Operation

Once the unit goes unoccupied and no heating or cooling demands exist, the unit stages off any active stages, the economizer and fan VFD outputs turn off and the Main Fan turns off. No outputs are active. If a space sensor is installed and the supply air or return air sensor is the controlling temperature, then the WMVAV Controller will monitor the space temperature for an unoccupied heating demand. If the space gets too cold, the unit will provide unoccupied heat until double the deadband amount has been restored. The economizer remains fully closed during this time. If the space temperature sensor is installed, then both heating and cooling occupied setpoints are setback and heating and cool-

Sequence Of Operations

ing demands are created when the space temperature exceeds either limit during unoccupied hours. The unoccupied setpoints are created by adding user adjustable offsets to the occupied setpoints. If the heating or cooling demand is satisfied, the unit will return to the off mode.

If a push-button override occurs during the off mode or an unoccupied heating or cooling demand, the unit will switch over to using the occupied heating and cooling setpoints as required by the configuration. This will remain in effect until the override times out or is cancelled by the user

Static Pressure & Fan VFD Control

The WMVAV Controller reads and controls Static Pressure in the duct system if it has been configured as a VAV air handler. Anytime the fan is operating, the WMVAV Controller is controlling Static Pressure. The Static Pressure Setpoint and Deadband limits are user adjustable along with a controlling interval. The static setpoints are entered as Inches of Water Gauge. The default setpoint is 0.5" WG. The control interval is the amount of time that elapses between each adjustment to the VFD signal. The default period is 10 seconds and should not be changed unless close observation reveals that the fan is "hunting" and not maintaining a stable pressure reading.

The normal control is to increase fan speed if the static is below the setpoint by the deadband amount and to decrease fan speed if the static is above the setpoint by the deadband amount. If the static ever rises 0.5" above the setpoint, the fan speed will be cut in half every control period until the pressure is brought under control. This is to prevent damage to the ductwork if all the air-valves are closed or some other blockage occurs in the ductwork.

Warning: The manufacturer does not assume responsibility for protecting the equipment from over pressurization!
The user should always install mechanical high static protection cutoffs to protect their system!

When the fans starts, the VFD signal will go to Minimum VFD % for heating. Anytime the fan is off the VFD signal will remain at zero volts.

If you configured your WMVAV Controller as a Constant Volume Unit, you can monitor the Static Pressure if the sensor is installed, but no control will occur.

Relief Pressure & VFD Control

If this option is selected, the building pressure will be maintained anytime the main supply fan is operating by varying a 0-10 VDC control signal on the optional Analog Input Expansion Board. The signal can drive either a Fan VFD signal or an Actuator to maintain the user adjust-

able Relief Pressure Setpoint. If you don't require a modulating control signal, you can also configure one of the relay outputs to activate whenever the relief pressure setpoint is exceeded. Only one relay should be configured for this operation. There is no staging of additional exhaust fan relays.

Optional Control Configurations

Exhaust Fan Control

See the previous section, Relief Pressure & VFD Control, for an explanation on how this relay output is used to maintain the building pressure.

Hot Gas Re-Heat And Dehumidification Control (If Available)

If your unit is equipped with Hot Gas Reheat and you configured your WMVAV controller for dehumidification control, you need to install a humidistat on the optional Binary Input Expansion Board, Input #1. You also need to configure one of the relays to operate in the Hot Gas Reheat mode.

The WMVAV controller activates a number of compressors based on the number of stages available. Anytime dehumidification is activated, the Supply Setpoint is calculated as being halfway between the Heating and Cooling setpoints if they are at least 2° apart. If the halfway point turns out to be 65°F or lower, the Supply Setpoint will default to 68°F.

Shown below are the initial compressor requirements when the dehumidification mode is entered. It assumes that the Gas Reheat and voltage outputs are active only as long as the compressors are running and the unit is still able to remain in the dehumidification mode.

For Constant Volume units the dehumidification mode occurs when the HVAC unit is in the Vent Mode and the humidity level has risen above the humidistat setpoint.

For VAV units using Supply Air Control, Supply Air Reset capabilities are removed during the dehumidification mode. No hot Gas Reheat Relay will be activated when in dehumidification mode with a VAV unit.

Number Of Compressors on HVAC Unit	Initial Compressor Stages Activated
1	1
2	1
4	1, 2
6	1, 2, 3
8	1, 2, 3, 4

Table 1: Compressor Staging For Dehumidification

In addition to the compressors, a gas reheat relay can activate after a user adjustable delay period if the supply air temperature is less than the heating setpoint. The gas reheat relay will be deactivated when the supply air temperature rises above the cooling setpoint.

Preheat Operation

In colder climates it is sometimes desirable to preheat the outside air being drawn into the air handler before it reaches the compressor coils. This option is available by setting a Low Ambient protection setpoint and by configuring one of the relay outputs as a Pre-Heater. Only one relay should be configured for this option and staging of preheat relays is not part of the control sequence.

Anytime the outdoor air temperature is below the Low Ambient setpoint and the main fan is running, the preheat relay will activate. It will remain on until the outdoor air rises 1°F above the setpoint or the main fan deactivates. It also requires the fan proving signal to be active if you have installed and configured a proof of flow contact closure on input #7. This output is not affected by any other mode of operation and will operate in *all* other HVAC modes of operation such as cooling or vent modes.

Air to Air Heat Pump

If you configured this WMVAV controller as an Air to Air Heat Pump unit, the following HVAC modes will occur. These may vary somewhat from those described in the VAV / Constant Volume sections of this manual.

You must configure the Heat Pump to use the Space Sensor to provide the heating or cooling calls, otherwise, incorrect HVAC decisions may be made. Although the system allows you to select one of the other two sensors for control, that is not the recommended method and proper operation cannot be guaranteed.

Once the heating or cooling mode is determined, the staging up and down of compressors is the same as described earlier in this manual. The only difference is that a Reversing Valve relay output is activated with the first compressor stage in the heating mode of operation. All staging up and down and minimum run and off times must be satisfied. These timers are described in the previous Heating and Cooling mode sections.

The Air to Air Heat Pump does not support the Hot Gas Re-Heat dehumidification mode of operation. If you have configured your unit for this operation, it will be ignored.

The Heat Pump can be configured to operate either in a VAV or a Constant Volume mode of operation. The warm-up mode is also available, if desired.

Caution: If you don't configure one of the relays to be the Reversing Valve, you will always get cooling whenever the compressors are activated in the heating mode!

Alarm Detection and Reporting

The WMVAV controller continuously performs self diagnostics during normal operations to determine if any operating failures have occurred. These failures can be reported to the user in several ways, depending on the type of system and options installed by the user.

If a Modular Service Tool or System Manager is connected, the alarms will be reported on the Status Screens. If the Prism computer graphic front end is installed, the alarms will be reported on the main screen of the program and logged to disk. If neither remote communication option is installed, the user can check for alarms by viewing LED2 on the WMVAV controller board. If everything is operating normally, the LED will blink once every 10 seconds. If there is a problem detected, the LED will flash a specific number of times every 10 seconds to indicate what the problem is. These flashes or "blink codes" are described below in order of priority. The highest priority condition must be corrected before any lower conditions can be observed and corrected. One blink is the lowest priority and indicates no alarms. Five blinks is the highest priority.

If the RemoteLink (modem) is installed, any alarm condition can initiate a callout to a pager to alert someone to the alarm condition. See the Prism computer front end program operations manual for further information on this topic.

LED Blinks This Number Of Times	Blink Code Description
1	Normal Operations. No Alarm Conditions
2	Pushbutton Override Is Active During Unoccupied Period
3	Space Temperature Sensor Failure Detected
4	Fan Proving Alarm
5	Unit In Force Mode

Table 2: Diagnostic Blink Codes

Sequence Of Operations

Force Modes or Overrides

The WMVAV Controller relay and analog outputs can be user overridden if the Modular Service Tool or the PRISM graphical front-end program is available. The modes of operation for the relays are:

- 0 = Normal Operation
- 1 = Forced ON
- 2 = Forced OFF

The analog outputs are forced if the user specifies a value between 0.0 and 10.0 VDC. To cancel the force mode, enter a value less than zero (-1.0 VDC).

When the analog outputs are forced, the display on the Modular Service Tool or front-end can be interpreted as the actual voltage. During normal operation, the display indicates the percentage signal applied based on the user defined voltage limits. For example, if the user defines a 2.0 VDC to 10.0 VDC range, then 50% would be 6.0 VDC instead of the 5.0 VDC applied when the range is 0.0 VDC to 10.0 VDC.

As mentioned, force modes can only be activated with an attached remote communications device listed above. Furthermore, the override condition can only remain in effect as long as the remote device is connected and communicating with the unit. That means that you cannot set an override condition and then “walk away” from the equipment with the override still active. The loss of communications or the removal of the remote interface will automatically terminate the override within 10 minutes. This is to protect the equipment and to prevent an override condition from remaining active indefinitely resulting in inefficient operation of the equipment.

Caution: No equipment protection is available during the force mode of operation. That means you could start a compressor without running the fan or create other conditions that WILL damage the HVAC equipment. WattMaster Controls, Inc. assumes no responsibility or liability for the misuse of these user overrides that cause damage to the HVAC equipment!

Internal Trend Logging

The WMVAV Controller continuously maintains an Internal Trend Log, which records a fixed set of values at an interval programmed by the user. These values can be retrieved only with the PRISM graphical front-end program. If you don't have the Remote Communications option with a front-end program, you do not have access to these logs.

There are 120 log positions available. Once the last (120th) position has been recorded, the log jumps back to the first position and begins overwriting the old data. This means the user is required to retrieve the logs at an interval that is shorter than the duration of the last 120 logs.

Shown below are some log intervals and the duration of 120 logs.

1 Minute Interval =	2 Hour Duration
15 Minute Interval =	30 Hour Duration
30 Minute Interval =	60 Hour Duration
60 Minute Interval =	120 Hour Duration

The fixed items in the log are listed below:

- Date
- Time
- Space Temperature
- Return Air Temperature
- Active Cooling Setpoint
- Active Heating Setpoint
- Supply Air Temperature
- Outdoor Air Humidity (0.0 if not installed)
- Outdoor Air Temperature
- Static Pressure
- Economizer Signal Percentage
- Supply Fan VFD Signal Percentage
- Relief Fan VFD Signal Percentage
- Onboard Relay Status (BIT Pattern)
- Expansion Board Relay Status (BIT Pattern)
- Supply Setpoint Reset Value
- Relief Pressure Reading

These items and values are explained in greater detail in the PRISM manual.

VAV Box Compatibility

If you have VAV Boxes installed on your job-site and have elected to use the WattMaster Controls VAVBOX Controllers, the WMVAV Controller is automatically “aware” of these boxes and can provide features such as unoccupied overrides from a box controller or unoccupied heating calls from a box controller. The WMVAV Controller also “broadcasts” its supply air temperature to any other units installed on the same communications loop and the boxes can use that information to determine warm-up mode or its heating/cooling/vent mode of operation. The System Manager, Modular Service Tool and computer front end program are also able to communicate with these VAVBOX Controllers and aid in providing the user with a complete VAV system on smaller buildings that do not require a full scale building automation system. See the VAVBOX Controller Technical Guide for information about installation and programming of the VAVBOX controllers.

If you have third party VAV Box Controllers installed, the WMVAV Controller can activate a relay to inform the boxes that it is operating in a warm-up mode, but no other information can be passed between the WMVAV Controller and its boxes so overrides and unoccupied heating demands cannot activate the WMVAV Controller to satisfy the calls. Your only option is to use the remote contact closures for Occupied/Unoccupied and possibly the HVAC Mode contact inputs provided by a separate BAS that is able to communicate with the box controllers.

Troubleshooting

Using LED's To Verify Operation

The WMVAV controller is equipped with LEDs that can be used as very powerful troubleshooting tools. There are four LEDs on the WMVAV controller board. Three of these LEDs are used in troubleshooting. See **Figure 18** for the LED locations. The LEDs and their uses are as follows:

“COMM”

This LED will light up to indicate system communications.

“PWR”

This LED will light up to indicate that 24 VAC power has been applied to the controller.

“LED1”

This LED is not used for this controller application.

“LED2”

This is the diagnostic blink code LED. It will light up and blink out diagnostic codes.

PWR LED Operations

When the WMVAV Controller is powered up the “PWR” LED should light up and stay on continuously. If it does not light up, check to be sure that you have 24 VAC connected to the board, that the wiring connections are tight and that they are wired for the correct polarity. The 24 VAC power must be connected so that all ground wires remain common. If after making all these checks the PWR LED does not light up, please contact WattMaster technical support for assistance.

COMM LED Operations

When power is applied to the controller The “COMM” LED will also light up. If this is a Stand Alone System (one controller only on the loop) or an Interconnected System (several WMVAV controllers tied together without a CommLink) the COMM LED will glow continuously. The COMM LED will flicker when you are connected to the WMVAV controller and you are entering setpoints with the Modular Service Tool or the System Manager. It will also flicker if this is a Networked System. If this is a Networked System (the system has a CommLink installed) the COMM LED should flicker rapidly indicating that the system is communicating. A “flicker” is defined as a brief moment when the LED turns off then back on. It may be easier to see this “flicker” if you cup your hand around the LED.

If the COMM LED does not operate as indicated above, first check the address switch setting. Verify the address switch as outlined in LED (Diagnostic LED) Operations below. If the address switch setting is correct and the COMM LED still does not behave as indicated above, check to be sure the operators interface is connected correctly. The System Manager must be connected to a local communications loop either at the WMVAV controller as shown in **Figure 20** or to another controller on the same local communications loop. If you are using the Modular Service Tool, verify that it is plugged in securely to the DIN connection on the WMVAV controller. See **Figure 20** for DIN connector location.

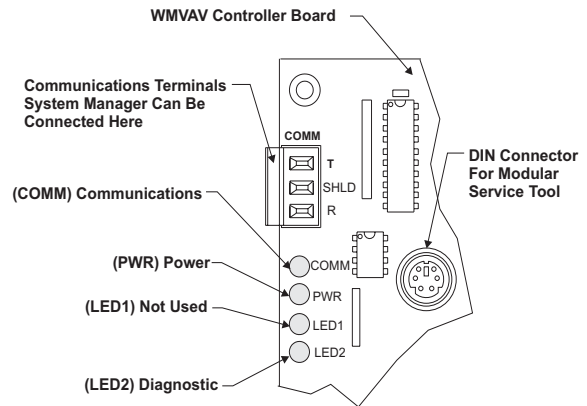

Figure 20: LED & Interface Connection Locations

If the COMM LED still does not behave correctly, check the voltages at the communications terminal block. Be sure the board is powered up for this test. Unplug the communications terminal block from the board and check the DC voltage between T and SHLD and between R and SHLD. Check the voltage with a digital multimeter set to DC volts. The voltage should be between 2.4 to 2.5 VDC between SHLD and either T or R. If your voltage is not in this range, you probably have a damaged driver chip that must be replaced. For driver chip replacement instructions, please see the WattMaster WMVAV Controls System Installation & Troubleshooting Guide for more information or contact the factory for further assistance.

LED2 (Diagnostic LED) Operations

When power is first applied, LED2 is turned off for 5 seconds. At this time LED2 will “blink” to indicate the setting of the address switch and then extinguish for another 5 seconds. Verify that the address switch setting is correct by counting the number of blinks. If the address switch setting is not correct, remove the communication loop terminal plug from the controller and then the power terminal plug. Correctly set the address switch setting (see **Figure 18**) with the dip switches on the controller, reconnect the power connection and then the communication loop. Reapply power to the controller and observe the blink code to verify the address is set correctly.

Troubleshooting

Note: Power to the Controller being addressed must always be cycled after changing address switch settings in order for the changes to take effect. Always unplug the communications terminal block before removing the power terminal block from the board. When finished reinstall the power terminal block first and then the communications terminal block.

If LED2 blinks the correct address your board is addressed correctly. If it does not light up at all, the board is not operating correctly and could be defective.

If all of these tests are made and the controller still doesn't operate, see the WattMaster VAV Component & System Wiring - Technical Guide for more information or contact the WattMaster Technical Support Toll Free Number at 866-918-1100 for further assistance.

Appendix

Sensor Checks

The following sensor voltage and resistance tables are provided to aid in checking sensors that appear to be operating incorrectly. Many system operating problems can be traced to incorrect sensor wiring. Be sure all sensors are wired per the wiring diagrams in this manual.

If the sensors still do not appear to be operating or reading correctly, check voltage and/or resistance to confirm that the sensor is operating correctly per the tables. Please follow the notes and instructions below each chart when checking sensors.

Temperature – Resistance – Voltage For Type III 10 K Ohm Thermistor Sensors

Temp (°F)	Resistance (Ohms)	Voltage @ Input (VDC)	Temp (°F)	Resistance (Ohms)	Voltage @ Input (VDC)	Temp (°F)	Resistance (Ohms)	Voltage @ Input (VDC)
-10	93333	4.620	60	14681	3.042	86	8153	2.297
-5	80531	4.550	62	14014	2.985	88	7805	2.242
0	69822	4.474	64	13382	2.927	90	7472	2.187
5	60552	4.390	66	12758	2.867	95	6716	2.055
10	52500	4.297	68	12191	2.810	100	6047	1.927
15	45902	4.200	69	11906	2.780	105	5453	1.805
20	40147	4.095	70	11652	2.752	110	4923	1.687
25	35165	3.982	71	11379	2.722	115	4449	1.575
30	30805	3.862	72	11136	2.695	120	4030	1.469
35	27140	3.737	73	10878	2.665	125	3656	1.369
40	23874	3.605	74	10625	2.635	130	3317	1.274
45	21094	3.470	75	10398	2.607	135	3015	1.185
50	18655	3.330	76	10158	2.577	140	2743	1.101
52	17799	3.275	78	9711	2.520	145	2502	1.024
54	16956	3.217	80	9302	2.465	150	2288	0.952
56	16164	3.160	82	8893	2.407			
58	15385	3.100	84	8514	2.352			

Thermistor Sensor Testing Instructions

Use the resistance column to check the thermistor sensor while disconnected from the controllers (not powered).

Use the voltage column to check sensors while connected to powered controllers. Read voltage with meter set on DC volts. Place the “-”(mi-

nus) lead on GND terminal and the “+”(plus) lead on the sensor input terminal being investigated.

*If the voltage is above 5.08 VDC, then the sensor or wiring is “open.”
If the voltage is less than 0.05 VDC, the sensor or wiring is shorted.*

OE271 Duct Static Pressure Sensor

Pressure @ Sensor (" W.C.)	Voltage @ Input (VDC)	Pressure @ Sensor (" W.C.)	Voltage @ Input (VDC)
0.00	0.25	2.60	2.20
0.10	0.33	2.70	2.28
0.20	0.40	2.80	2.35
0.30	0.48	2.90	2.43
0.40	0.55	3.00	2.50
0.50	0.63	3.10	2.58
0.60	0.70	3.20	2.65
0.70	0.78	3.30	2.73
0.80	0.85	3.40	2.80
0.90	0.93	3.50	2.88
1.00	1.00	3.60	2.95
1.10	1.08	3.70	3.03
1.20	1.15	3.80	3.10
1.30	1.23	3.90	3.18
1.40	1.30	4.00	3.25
1.50	1.38	4.10	3.33
1.60	1.45	4.20	3.40
1.70	1.53	4.30	3.48
1.80	1.60	4.40	3.55
1.90	1.68	4.50	3.63
2.00	1.75	4.60	3.70
2.10	1.83	4.70	3.78
2.20	1.90	4.80	3.85
2.30	1.98	4.90	3.93
2.40	2.05	5.00	4.00
2.50	2.13		

OE271 Pressure Sensor Testing Instructions

Use the voltage column to check the Duct Static Pressure Sensor while connected to powered controllers. Read voltage with meter set on DC volts. Place the “-”(minus) lead on GND terminal and the “+”(plus) lead on the 0-5 pin terminal on (JP1) with the jumper removed. Be sure to replace the jumper after checking.

OE258 Building Pressure Sensor

Pressure @ Sensor (" W.C.)	Voltage @ Input (VDC)	Pressure @ Sensor (" W.C.)	Voltage @ Input (VDC)
-0.25	0.00	0.01	2.60
-0.24	0.10	0.02	2.70
-0.23	0.20	0.03	2.80
-0.22	0.30	0.04	2.90
-0.21	0.40	0.05	3.00
-0.20	0.50	0.06	3.10
-0.19	0.60	0.07	3.20
-0.18	0.70	0.08	3.30
-0.17	0.80	0.09	3.40
-0.16	0.90	0.10	3.50
-0.15	1.00	0.11	3.60
-0.14	1.10	0.12	3.70
-0.13	1.20	0.13	3.80
-0.12	1.30	0.14	3.90
-0.11	1.40	0.15	4.00
-0.10	1.50	0.16	4.10
-0.09	1.60	0.17	4.20
-0.08	1.70	0.18	4.30
-0.07	1.80	0.19	4.40
-0.06	1.90	0.20	4.50
-0.05	2.00	0.21	4.60
-0.04	2.10	0.22	4.70
-0.03	2.20	0.23	4.80
-0.02	2.30	0.24	4.90
-0.01	2.40	0.25	5.00
0.00	2.50		

OE258 Building Pressure Sensor Testing Instructions

Use the voltage column to check the Building Static Pressure Sensor while connected to a powered expansion board. Read voltage with meter set on DC volts. Place the “-”(minus) lead on terminal labeled GND and the “+” lead on terminal AIN4 on the Analog Input/Output Expansion Board.

Appendix

OE265 Relative Humidity Transmitters – Humidity vs. Voltage							
Humidity Percentage (RH)	Voltage @ Input (VDC)	Humidity Percentage (RH)	Voltage @ Input (VDC)	Humidity Percentage (RH)	Voltage @ Input (VDC)	Humidity Percentage (RH)	Voltage @ Input (VDC)
0%	1.00	26%	2.04	52%	3.08	78%	4.12
2%	1.08	28%	2.12	54%	3.16	80%	4.20
4%	1.16	30%	2.20	56%	3.24	82%	4.28
6%	1.24	32%	2.28	58%	3.32	84%	4.36
8%	1.32	34%	2.36	60%	3.40	86%	4.44
10%	1.40	36%	2.44	62%	3.48	88%	4.52
12%	1.48	38%	2.52	64%	3.56	90%	4.60
14%	1.56	40%	2.60	66%	3.64	92%	4.68
16%	1.64	42%	2.68	68%	3.72	94%	4.76
18%	1.72	44%	2.76	70%	3.80	96%	4.84
20%	1.80	46%	2.84	72%	3.88	98%	4.92
22%	1.88	48%	2.92	74%	3.96	100%	5.00
24%	1.96	50%	3.00	76%	4.04		

OE265-03 Relative Humidity Sensor

Testing Instructions:

Use the voltage column to check the Humidity Sensor while connected to a powered expansion board. Read voltage with meter set on DC volts. Place the “-”(minus) lead on terminal labeled GND and the “+” lead on terminal AIN4 on the Analog Input/Output Expansion Board.

Notes



Form: WM-WMVAV-TGD-01A

Printed in the USA

May 2004

All rights reserved

Copyright 2004

WattMaster Controls Inc. • 8500 NW River Park Drive • Parkville MO • 64152

Phone (816) 505-1100

E-mail: mail@wattmaster.com

Fax (816) 505-1101