

LF24-3 US - Damper Actuator

On/Off, Floating Point, Spring Return, 24 V



Technical Data	
Power Supply	24 VAC, ±20%, 50/60 Hz, 24 VDC, ±10%
Power consumption in operation	2.5 W
Power consumption in rest position	1 W
Transformer sizing	5 VA (class 2 power source)
Shaft Diameter	3/8" to 1/2" round, centers on 1/2"
Electrical Connection	18 GA plenum cable, 3 ft [1 m], with 1/2" conduit connector
Overload Protection	electronic throughout 0° to 95° rotation
Electrical Protection	actuators are double insulated
Input Impedance	1000 Ω (0.6 W)
Angle of rotation	Max. 95°
Torque motor	35 in-lb [4 Nm]
direction of rotation motor	reversible with built-in switch
direction of rotation spring-return	reversible with CW/CCW mounting
Position indication	visual indicator, 0° to 95° (0° is full spring return position)
Running Time (Motor)	150 sec constant, independent of load
Running Time (Fail-Safe)	<25 sec @ -4...122°F [-20...50°C], <60 sec @ -22°F [-30°C]
Ambient humidity	5...95% r.H. non-condensing
Ambient temperature	-22...122°F [-30...50°C]
Storage temperature	-40...176°F [-40...80°C]
Degree of Protection	IP54, NEMA 2
Housing material	zinc coated steel
Agency Listing	cULus acc. To UL 873 and CAN/CSA C22.2 No. 24-93
Noise level, motor	<30 dB (A)
Noise Level (Fail-Safe)	<62 dB (A)
Maintenance	maintenance free
Quality Standard	ISO 9001
Weight	3.31 lb [1.51 kg]

†Rated Impulse Voltage 800V, Type of action 1.AA, Control Pollution Degree 3

Torque min. 35 in-lb, for control of air dampers.

Application

For modulation or On/Off, fail-safe control of dampers in HVAC systems. Actuator sizing should be done in accordance with the damper manufacturer's specifications. The actuator is mounted directly to a damper shaft from 3/8" up to 1/2" in diameter by means of its universal clamp, 1/2" shaft centered at delivery. For shafts up to 3/4" use K6-1 accessory. A crank arm and several mounting brackets are available for applications where the actuator cannot be direct coupled to the damper shaft. Control is floating point from a triac or relay, or On/Off from an auxiliary contact from a fan motor contactor, controller or manual switch.

Operation

The LF series actuators provide true spring return operation for reliable fail-safe application and positive close-off on air tight dampers. The spring return system provides consistent torque to the damper with, and without, power applied to the actuator. The LF series provides 95° of rotation and is provided with a graduated position indicator showing 0 to 95°. The LF uses a brushless DC motor which is controlled by an Application Specific Integrated Circuit (ASIC) and a microprocessor. The microprocessor provides the intelligence to the ASIC to provide a constant rotation rate and to know the actuator's exact fail-safe position. The ASIC monitors and controls the brushless DC motor's rotation and provides a digital rotation sensing function to prevent damage to the actuator in a stall condition. The actuator may be stalled anywhere in its normal rotation without the need of mechanical end switches. Power consumption is reduced in holding mode.

Dimensions (Inches[mm])

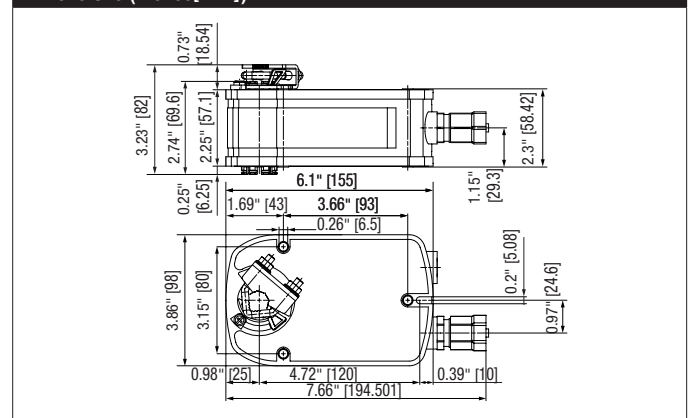

Safety Notes

⚠ **WARNING:** For Belimo Products sold in California, these Products do or may contain chemicals which are known to the State of California to cause cancer and or birth defects or other reproductive harms. For more information see www.p65warnings.ca.gov.

Accessories	
AV6-20	Shaft extension
K6 US	Standard LF clamp (3/8" to 1/2").
K6-1	Spindle clamp reversible
KG10A	Ball joint
KG8	Ball joint
KH8	Damper crank arm
KH-LF	Actuator arm
KH-LFV	V-bolt Kit for KH-LF.
LF-P	Anti-rotation bracket LF.
SH10	Push rod for KG10A ball joint (36" L, 3/8" diameter).
SH8	Push rod for KG6 & KG8 ball joints (36" L, 5/16" diameter).
TOOL-06	8 mm and 10 mm wrench.
ZDB-LF	Angle of rotation limiter
ZF8-LF	Form fit adapter
ZG-109	Right angle bracket for ZS-260.
ZG-110	Stand-off bracket for ZS-260.
ZG-112	LF right angle bracket 4-1/2x5-1/2x2-1/2" (HxWxD).
ZG-DC1	Damper clip for damper blade, 3.5" width.
ZG-DC2	Damper clip for damper blade, 6" width.
ZG-LF112	LF crankarm adaptor kit (includes ZG-112).
ZG-LF2	LF crankarm adaptor kit (T bracket included).
ZG-LMSA-1	Shaft extension for 3/8" diameter shafts (4" L).
ZG-LMSA-1/2-5	Shaft extension for 1/2" diameter shafts (5" L).
ZS-100	Weather shield - galvaneal 13x8x6" (LxWxD).
ZS-101	Base plate for ZS-100.
ZS-150	Weather shield - PC w/ foam seal 16x8-3/8x4" (LxWxD).
ZS-260	Explosion proof housing.
ZS-300	NEMA 4X, 304 stainless steel enclosure.
ZS-300-5	NEMA 4X, 316L stainless steel enclosure.
ZS-300-C1	1/2" shaft adaptor, standard with ZS-300(-5).
ZS-300-C2	3/4" shaft adaptor for ZS-300(-5).
ZS-300-C3	1" shaft adaptor for ZS-300(-5).
P475	Shaft mount, non-Mercury aux. switch for 1/2" dia. shafts.
P475-1	Shaft mount, non-Mercury aux. switch for 1" dia. shafts.
PS-100	Actuator power supply and control simulator.
ZG-X40	120 to 24 VAC, 40 VA transformer.

Typical Specification

Floating point, On/Off spring return damper actuators shall be direct coupled type which require no crank arm and linkage and be capable of direct mounting to a shaft up to a 3/4" diameter and centers on a 1/2" shaft (default). The actuators must be designed so that they may be used for either clockwise or counter clockwise fail-safe operation. Actuators shall have an external direction of rotation switch to reverse control logic. Actuators shall use a brushless DC motor and be protected from overload at all angles of rotation. If required, one SPDT auxiliary switch shall be provided having the capability of being adjustable. Actuators with auxiliary switch must be constructed to meet the requirements for Double Insulation so an electrical ground is not required to meet agency listings. Run time shall be constant and independent of torque. Actuators shall be cULus listed, have a 5 year warranty, and be manufactured under ISO 9001 International Quality Control Standards. Actuators shall be as manufactured by Belimo.

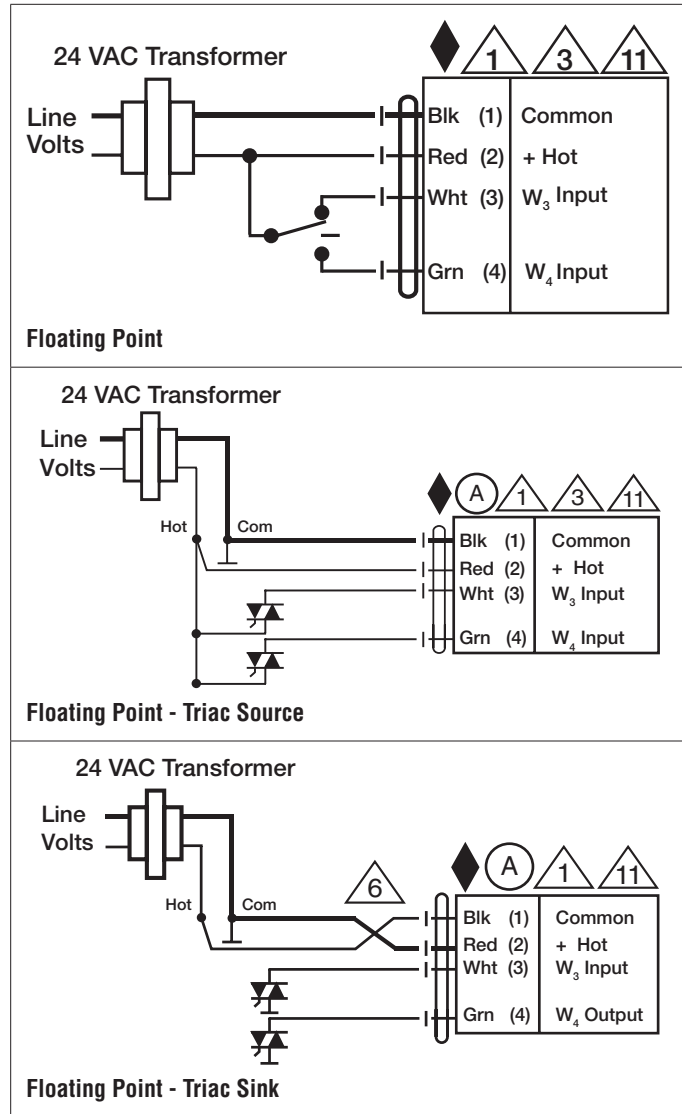

LF24-3 US - Damper Actuator

On/Off, Floating Point, Spring Return, 24 V

Wiring Diagrams



WARNING! LIVE ELECTRICAL COMPONENTS!

During installation, testing, servicing and troubleshooting of this product, it may be necessary to work with live electrical components. Have a qualified licensed electrician or other individual who has been properly trained in handling live electrical components perform these tasks. Failure to follow all electrical safety precautions when exposed to live electrical components could result in death or serious injury.



Meets cULus requirements without the need of an electrical ground connection.



Actuators with appliance cables are numbered.



Provide overload protection and disconnect as required.



Actuators may also be powered by 24 VDC.



Actuators Hot wire must be connected to the control board common. Only connect common to neg. (-) leg of control circuits. Terminal models (-T) have no-feedback.



Actuators may be connected in parallel if not mechanically linked. Power consumption and input impedance must be observed.