

# FX30E/FX60E Supervisory Controllers Installation Instructions

FX30E/FX60E

Part No. 24-10174-115, Rev. D

Issued July 16, 2015

Refer to the [QuickLIT Web site](#) for the most up-to-date version of this document.

## Application

The FX30E and FX60E are web-based supervisory class controllers in the Facility Explorer product family. The FX30E/FX60E manages networks of field controllers using open communication protocols, such as N2, LONWORKS®, and BACnet® protocols.

Figure 1: FX30E Supervisory Controller



## North American Emissions Compliance

### United States

This equipment has been tested and found to comply with the limits for a Class A digital device pursuant to Part 15 of the FCC Rules. These limits are designed to provide reasonable protection against harmful interference when this equipment is operated in a commercial environment. This equipment generates, uses, and can radiate radio frequency energy and, if not installed and used in accordance with the instruction manual, may cause harmful interference to radio communications. Operation of this equipment in a residential area may cause harmful interference, in which case the users will be required to correct the interference at their own expense.

### Canada

This Class (A) digital apparatus meets all the requirements of the Canadian Interference-Causing Equipment Regulations.

Cet appareil numérique de la Classe (A) respecte toutes les exigences du Règlement sur le matériel brouilleur du Canada.

## Installation

### Parts Included

Unpack the FX30E/FX60E and accessories (power module, option cards), if ordered. Inspect the contents of the packages for damaged or missing components. If damaged, notify the appropriate carrier and return any damaged components for repair or replacement.

Included in this package are the following items:

- FX Supervisory Series controller
- Hardware bag containing a grounding wire with quick disconnect 0.187 in. (4.75 mm) female connector.
- Power module (if ordered). The power module may be one of the following:
  - LP-FXPM24-0 (24 VAC, DIN rail mountable)
  - LP-FXPM263-0 (90-263 VAC, DIN rail mountable)
  - LP-FXPMUS-0 (90-240 VAC, with U.S. wall adapter)
  - LP-FXPMEU-0 (90-240 VAC, with European wall adapter)
  - LP-FXPMUK-0 (90-240 VAC, with U.K. wall adapter)
- Communication cards (if ordered):
  - LP-FXLONFTT-1
  - LP-FXRS232-0
  - LP-FXRS485-0
  - LP-FXWTC-0
- Expansion Input/Output (NDIO) Modules (if ordered)
  - LP-FXNDIO16-0
  - LP-FXNDIO34-0

## Materials and Special Tools Needed

You may require the following materials and tools for installation:

- a suitable power module, such as one of the following types:
  - 24 VAC or 24 VDC, in-line, DIN mount capable, with grounding wire
  - 120-240 VAC, in-line, DIN mount capable, with grounding wire
  - FX-PM: external wall-mount power adapter (input 90-254 VAC, 50-60 Hz, output: 15 VDC, 1A), where FX-PM varies by AC wall plug, for installation locale (for example, FX-PMUS for U.S. or Japan installation, FX-PMEU for European installations, type C plug, or FX-PMUK for United Kingdom installations, type B plug)
- if using a 24 VAC power module, either one of the following:
  - UL listed, Class 2, 24 VAC transformer, rated at minimum of 7.5 VA to 20 VA (approximate range of controller alone, to fully expanded unit with four additional NDIO16 modules and other option boards). A dedicated transformer is required.
  - 24 VDC power supply, capable of supplying at least 1 A (24 W)
- DIN Rail: type NS35/7.5 (35 x 7.5 mm) and DIN rail end clips. Length of DIN rail depends on the number of optional DIN rail mounted options.
- suitable tools and fasteners for mounting unit and accessories.
- #2 Phillips screwdriver: used to install and remove any option card.
- small flat-blade screwdriver: used for making wiring connections to removable screw terminal plugs and mounting and removing modules from the DIN Rail.

## Safety Precautions

The following information relates to the installation and startup of the FX30E/FX60E.



**Risk of Electric Shock.** Disconnect the power supply before making electrical connections. Contact with components carrying hazardous voltage can cause electric shock and may result in severe personal injury or death.

**AVERTISSEMENT: Risque de décharge électrique.**

Débrancher l'alimentation avant de réaliser tout branchement électrique. Tout contact avec des composants conducteurs de tensions dangereuses risque d'entraîner une décharge électrique et de provoquer des blessures graves, voire mortelles.

**Important:** Use copper conductors only. Make all wiring connections in accordance with local, national, and regional regulations. Do not exceed the FX30E/FX60E electrical ratings.

**Important:** Do not install or use the FX30E/FX60E in or near environments where corrosive substances or vapor could be present. Exposure of the FX30E/FX60E to corrosive environments may damage the device's internal components, and will void the warranty.

**Important:** Use this FX30E/FX60E only as an operating control. Where failure or malfunction of the FX30E/FX60E could lead to personal injury or property damage to the controlled equipment or other property, additional precautions must be designed in the control system. Incorporate and maintain other devices, such as supervisory or alarm systems or safety or limit controls, intended to warn of or protect against failure or malfunction of the FX30E/FX60E.

## Static Discharge Precautions

Static charges produce voltages high enough to damage electronic components. The microprocessors and associated circuitry within an FX30E/FX60E are sensitive to static discharge.

**Important:** Work in a static-free area. Discharge any static electricity you may have accumulated. Discharge static electricity by touching a known, securely grounded object. Do not handle the Printed Circuit Board (PCB) without proper protection against static discharge. Use a wrist strap when handling PCBs. Secure the wrist strap clamp to earth ground.

**Important:** Turn off power to the FX30E/FX60E before inserting or unplugging accessory modules. Wait for the LED activity to stop (all LEDs off).



**Risk of Property Damage.** Do not apply power to the system before checking all wiring connections. Short circuited or improperly connected wires may result in permanent damage to the equipment.

**MISE EN GARDE: Risque dégâts matériels.** Ne pas mettre le système sous tension avant d'avoir vérifié tous les raccords de câblage. Des fils formant un court-circuit ou connectés de façon incorrecte risquent d'endommager irrémédiablement l'équipement.

## Accessories

The FX30E/FX60E has a 20-pin, right-angle, Euro-DIN connector that accepts accessory modules. The connector provides power and signal lines to any connected modules. The connector is located on the end of the FX30E/FX60E opposite the option cards.

Each accessory module has a DIN-mount base, and typically provides two 20-pin connectors that allow you to chain multiple accessories (see DIN Rail Mounting Instructions). [Table 1](#) lists the currently available modules.

## Accessory Module Details

Table 1: Accessory Module Details

Model	Description	Notes
LP-FXPM24-0	Power module for FX30E/FX60E 24 VAC/DC, DIN rail mountable	Install only one power module per FX30E/FX60E, regardless of type
LP-FXPM263-0	Power module for FX30E/FX60E 90-263 VAC, DIN rail mountable	Install only one power module per FX30E/FX60E, regardless of type.
LP-FXNDIO16-0	16 channel input/output module for FX30E/FX60E, DIN rail mountable	Provides the following I/O points: <ul style="list-style-type: none"> <li>• 8 universal inputs (UIs)</li> <li>• 4 digital outputs (DOs), single-pole single-throw (SPST) relay type</li> <li>• 4 analog outputs (AOs) (0-10 VDC)</li> </ul> Up to four (maximum) NDIO16 accessory modules are supported
LP-FXNDIO34-0	34 channel input/output module for FX30E/FX60E, DIN rail mountable. In addition, the NDIO34 provides power to the attached FX30E/FX60E, using an externally supplied 24 VAC transformer or 24 VDC power supply.	Provides the following I/O points: <ul style="list-style-type: none"> <li>• 16 universal inputs (UIs)</li> <li>• 10 digital outputs (DOs), SPST relay type</li> <li>• 8 analog outputs (AOs) (0-10 VDC)</li> </ul> One NDIO34 plus up to 2 additional NDIO16 modules are supported. Do not power the NDIO34 if using a separate wall plug power module.

## Mounting

Mount the FX30E/FX60E in a location that allows clearance for wiring, servicing, and module removal.

Follow these recommendations and precautions when mounting and installing the unit.

- Use this controller for indoor use only. Do not expose the unit to ambient conditions outside the range of 0 to 50°C (32 to 122°F) and relative humidity outside the range of noncondensing 5 to 95% (Pollution Degree 3).
- Supply voltage requirements are as follows:
  - Allowable voltage fluctuation to -15%, +10%, Temporary overvoltages +/- 15%
  - Transient overvoltages: Overvoltage Category 2
- For a controller mounted inside an enclosure, ensure that the enclosure is designed to keep the unit within its required operating range (considering a 20-watt dissipation by the controller). This enclosure is especially important if the controller is mounted inside an enclosure with other heat producing equipment.
- Do not mount the unit:
  - in an area where excessive moisture, corrosive fumes, or explosive vapors are present
  - where vibration or shock is likely to occur
  - in a location subject to electrical noise. This includes the proximity of large electrical contactors, electrical machinery, welding equipment, variable frequency drives, and spark igniters.

### Physical Mounting

The following information applies to the physical mounting of the FX30E/FX60E.

- You do not need to remove the cover before mounting.
- Mount the FX30E/FX60E in any orientation.

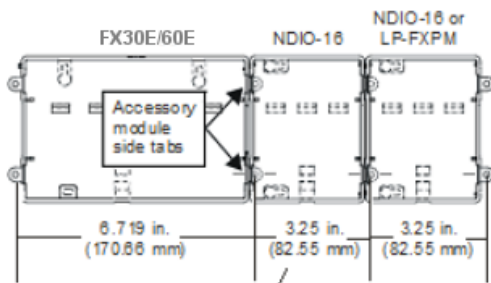
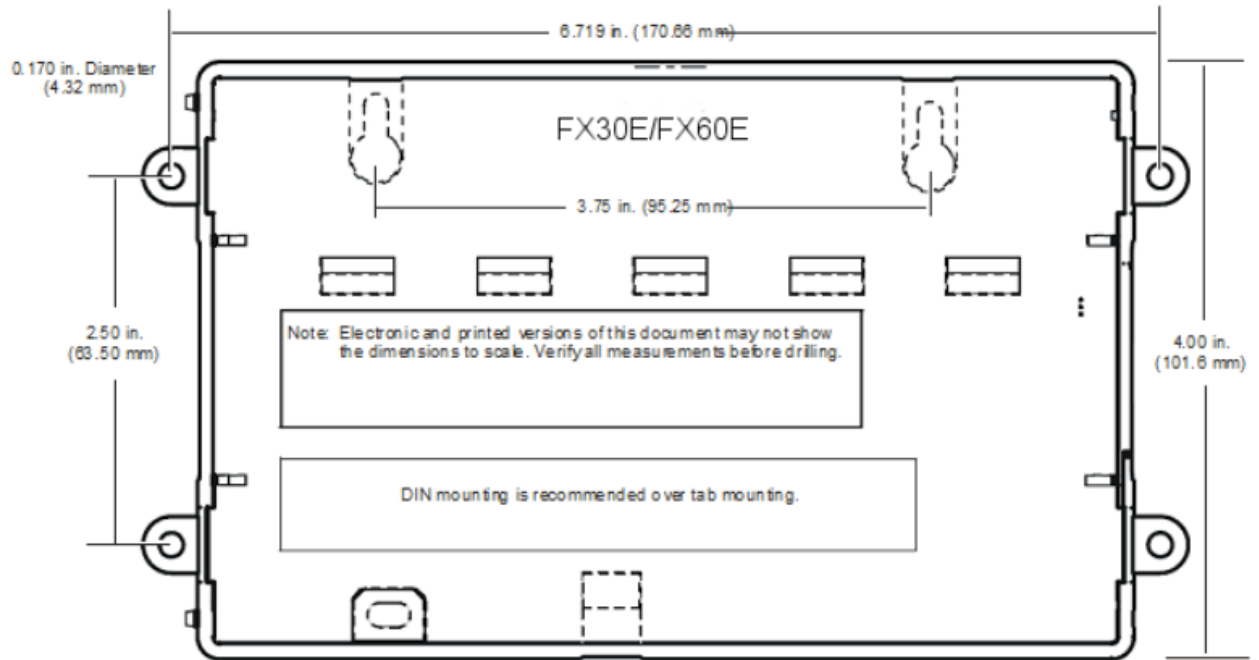
- Mount the unit on a 35-mm wide DIN rail (recommended). The FX30E/FX60E unit base and its accessories have molded DIN rail slots and locking clips. Mounting these components on a DIN rail ensures accurate alignment of connectors between all modules.
- If DIN rail mounting is impractical, use screws in mounting tabs on the FX30E/FX60E and in any end-connected accessory (power module, NDIO module). See [Figure 2](#) for tab dimensions.

### DIN Rail Mounting Instructions

1. Securely install the DIN rail using at least two screws near both ends of the rail.
2. Position the FX30E/FX60E on the rail, then tilt it to hook the DIN rail tabs over one edge of the DIN rail ([Figure 3](#)).
3. Use a screwdriver to pry down the plastic locking clip, and push the FX30E/FX60E down and in, which forces the locking clip to snap over the edge of the DIN rail.
4. Mount the accessory modules (NDIO modules and power module) onto the DIN rail in the same manner ([Figure 5](#)). See [Table 1](#) for quantities allowed.
5. Slide the accessory along the DIN rail to connect its 20-position plug into the FX30E/FX60E.
6. Repeat these instructions for all accessories, until all are mounted on the DIN rail and firmly connected to each other. For an example, see [Figure 4](#).

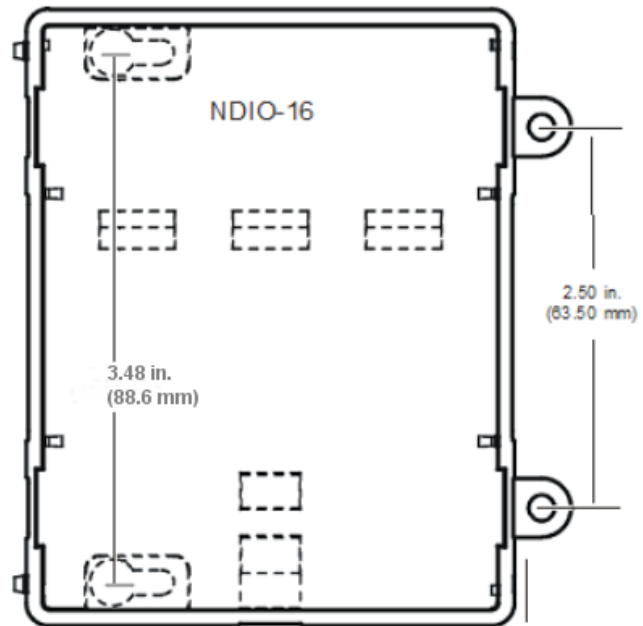
To keep the final assembly together, secure the assembly at both ends with DIN rail end-clips. This action also prevents the assembly from sliding on the DIN rail. See [Figure 4](#).

**Figure 2: Tab Mounting Dimension, in. (mm)**

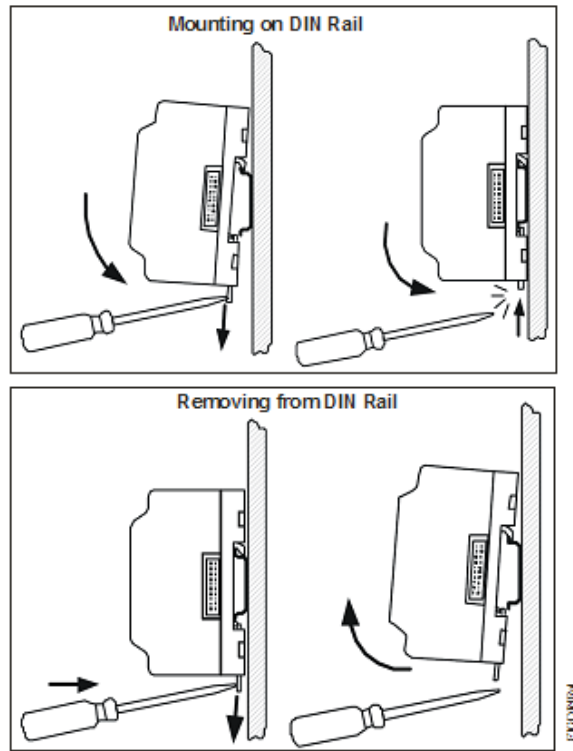


Distance between center of tabs from one unit to another unit.

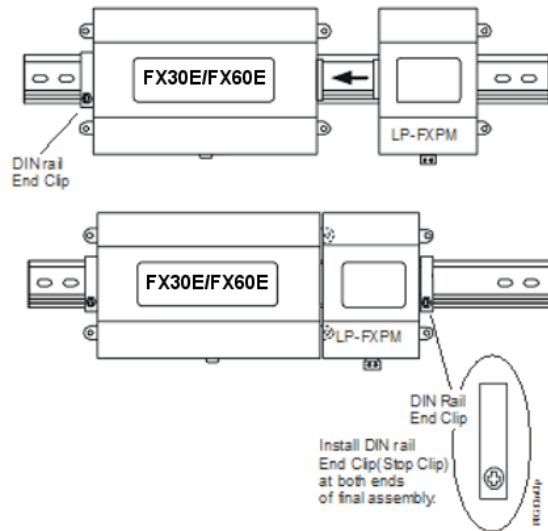
If mounting accessory modules, future removal or replacement of the FX30E/FX60E is simplified if you do not install screws in the accessory module side tabs of the controller (see above).



**Figure 3: DIN Rail Mounting**

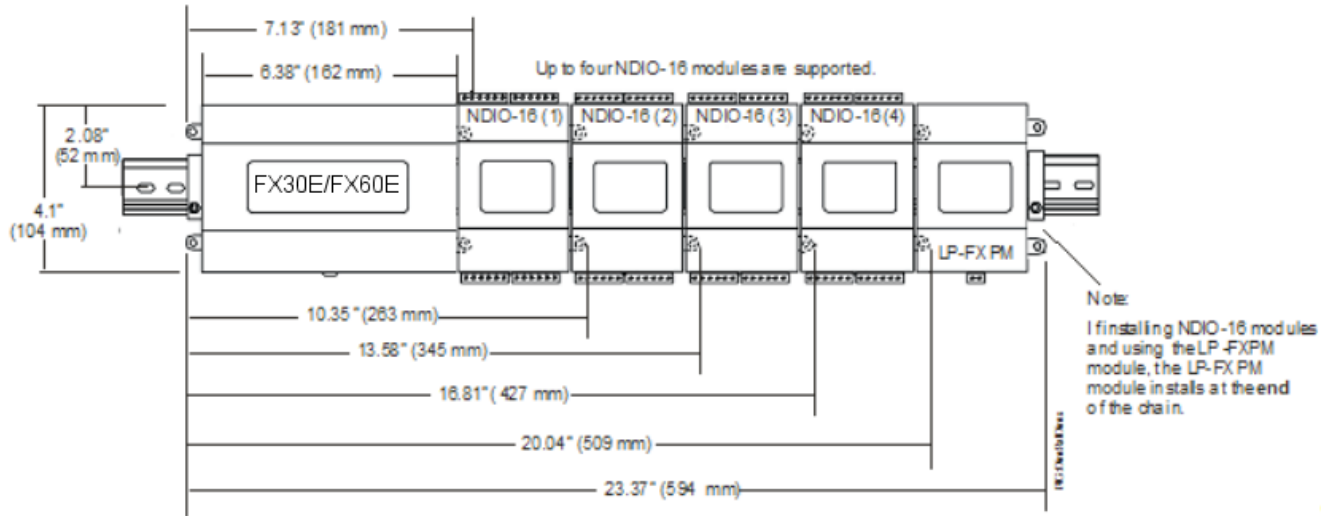


**Figure 4: Using End Clips to Secure Modules**





**Figure 5: Mounting Accessories**



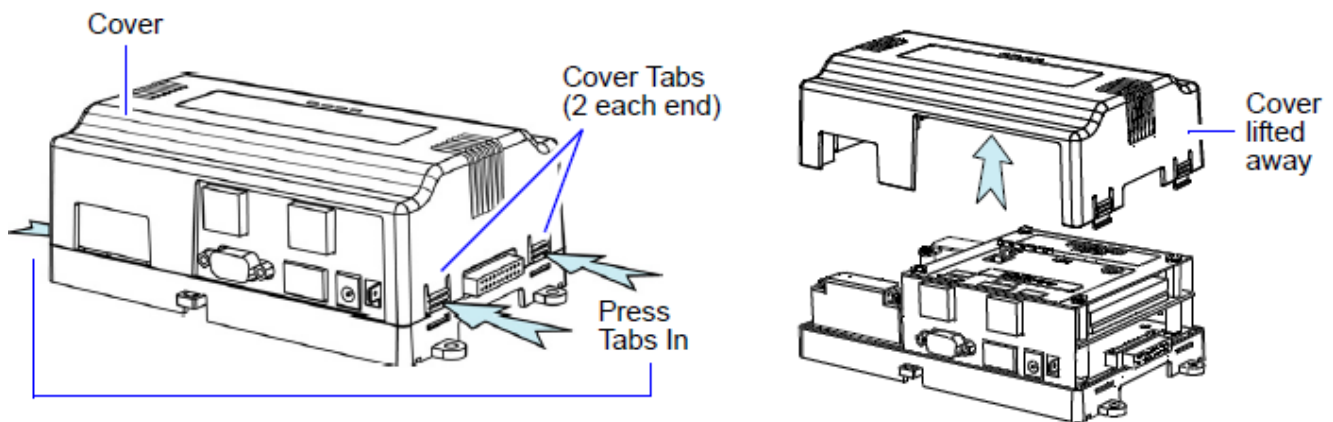
## Removing and Replacing the Cover

The FX30E/FX60E cover is removable. You must remove the FX30E/FX60E cover to connect the optional battery on a new unit, to replace the optional battery on an existing unit, or to install any optional communication cards. The cover snaps onto the base with four plastic tabs (two on each end). To remove the cover, press in the four tabs on both ends of the unit and lift off the cover.

**Note:** If accessory modules are plugged into the FX30E/FX60E, you may need to slide them away from the unit to get to the cover tabs.

To replace the cover, position it so the cutout area for the communication ports is correct, then push inward to snap in place.

**Figure 6: Removing and Replacing the Cover**

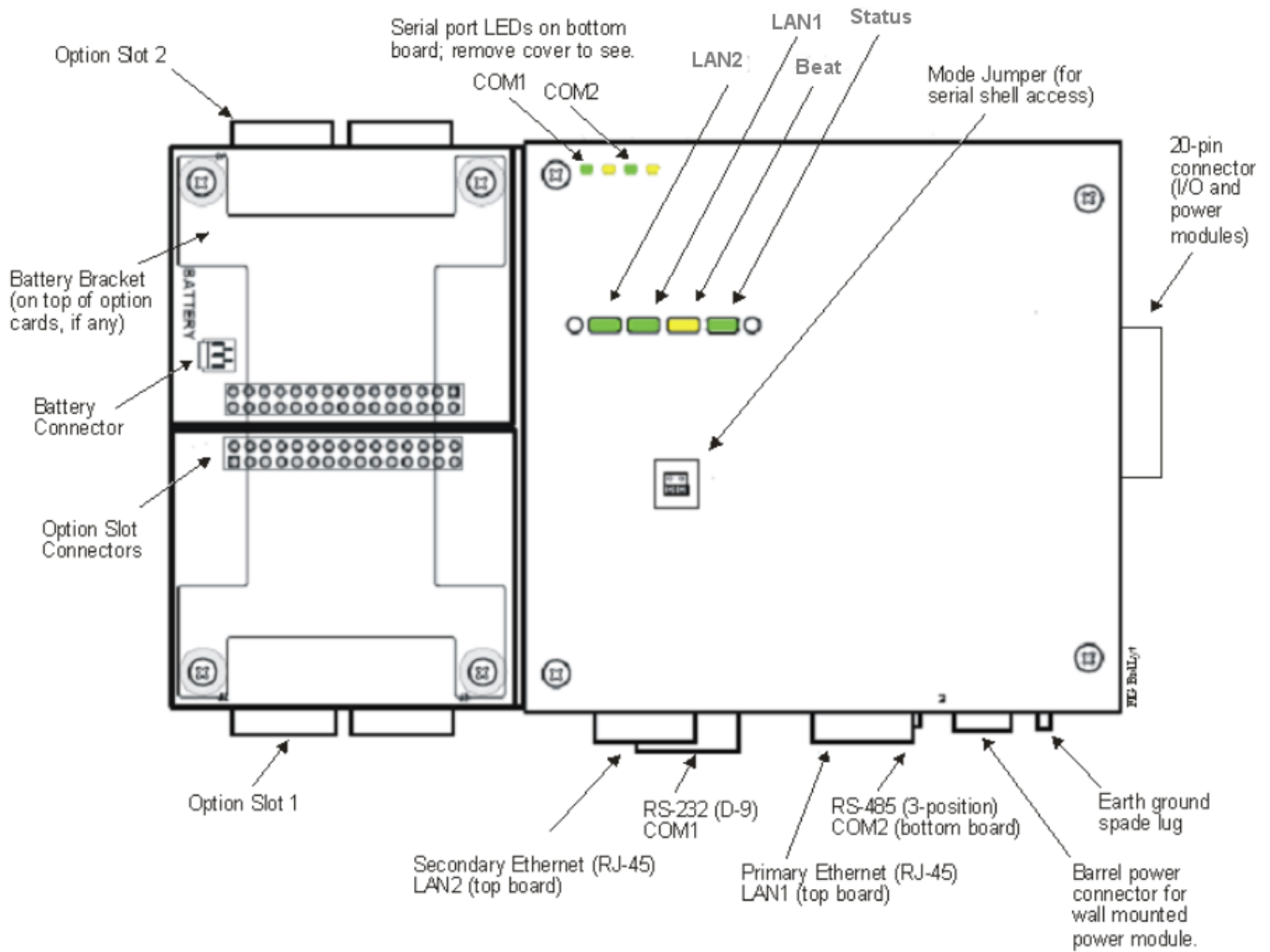


# Board Layout

See [Figure 7](#) for the location of LEDs, option slots, and other features of the FX30E/FX60E. See Figure 10 for a side view of communication ports and other features. The FX30E/FX60E ships with onboard static RAM (SRAM) that can provide station backup during power loss, and also has two open option card slots for a variety of available option cards.

**Note:** An optional NiMH battery pack is included, but not connected. For connection instructions, see [Backup Configurations](#).

**Figure 7: FX30E/FX60E Board Layout Details**





## Expansion Options

The FX30E/FX60E provides for field-installable expansion with two options:

- Option Cards: these are installed on connectors inside the FX30E/FX60E base unit. See Option Cards.
- Accessory Modules: these are chained onto the FX30E/FX60E's 20-pin connector. See Accessories.

## Option Cards

The FX30E/FX60E has two options slots for custom option cards designed for use with the FX30E/FX60E. Each slot has a 30-pin connector on the FX30E/FX60E base unit.



**Risk of Property Damage.** Do not apply power to the system before checking all wiring connections. Short circuited or improperly connected wires may result in permanent damage to the equipment.

**MISE EN GARDE: Risque dégâts matériels.** Ne pas mettre le système sous tension avant d'avoir vérifié tous les raccords de câblage. Des fils formant un court-circuit ou connectés de façon incorrecte risquent d'endommager irrémédiablement l'équipement.

**Important:** Power to the controller must be off when installing or removing option cards or damage will occur.

**Important:** Be careful to plug an option card into the connector properly with its pins properly aligned.

Option cards typically provide additional communication capabilities, such as those listed in [Table 2](#). For a list of supported COM port and slot assignments for the option cards, see [Table 3](#).

**Table 2: Option Card Details**

Model	Description	Number of Option Cards Allowed per Controller
LP-FXLONFTT-1	LONWORKS FTT-10A adapter with a 2-position removable screw terminal plug	One or two
LP-FXRS485-0	Dual, optically isolated, RS-485 adapter with two 3-position removable screw terminal connector plugs	One or two
LP-FXRS232-0	Single port RS-232 adapter, with a DB-9M connector	One or two
LP-FXWTC-0	Wireless TEC Card (WTC) with direct mount antenna	One
LP-FXSED-0	Sedona Framework™ option card	One
LP-FXGPRS-0	GPRS Modem card	One
LP-FXGPRSW-0	GPRS Modem option card with Wyleless™ SIM card	One

**Table 3: COM Port and Option Slot Assignments for FX30E/FX60E Option Cards**

Option Slot 1	Option Slot 2	Onboard RS232	Onboard RS485
None	None	COM1	COM2
RS-232 = COM3	None	COM1	COM2
RS-232 = COM3	RS-232 = COM4	COM1	COM2
RS-232 = COM3	RS-485 = COM4, COM5	COM1	COM2
RS-232 = COM3	LON = LON1	COM1	COM2
RS-232 = COM3	Sedona = COM4	COM1	COM2
RS-232 = COM3	GPRS = COM4, COM5	COM1	COM2

**Table 3: COM Port and Option Slot Assignments for FX30E/FX60E Option Cards**

<b>Option Slot 1</b>	<b>Option Slot 2</b>	<b>Onboard RS232</b>	<b>Onboard RS485</b>
RS-485 = COM3, COM4	None	COM1	COM2
RS-485 = COM3, COM4	RS-232 = COM5	COM1	COM2
RS-485 = COM3, COM4	RS-485 = COM5, COM6	COM1	COM2
RS-485 = COM3, COM4	LON = LON1	COM1	COM2
RS-485 = COM3, COM4	Sedona = COM5	COM1	COM2
RS-485 = COM3, COM4	GPRS = COM5, COM6	COM1	COM2
LON = LON1	None	COM1	COM2
LON = LON1	RS-232 = COM3	COM1	COM2
LON = LON1	RS-485 = COM3, COM4	COM1	COM2
LON = LON1	LON = LON2	COM1	COM2
LON = LON1	Sedona = COM3	COM1	COM2
LON = LON1	GPRS = COM3, COM4	COM1	COM2
Wireless TEC = COM1	None	Disabled	COM2
Wireless TEC = COM1	RS-232 = COM3	Disabled	COM2
Wireless TEC = COM1	RS-485 = COM3, COM4	Disabled	COM2
Wireless TEC = COM1	LON = LON1	Disabled	COM2
Wireless TEC = COM1	Sedona = COM3	Disabled	COM2
Wireless TEC = COM1	GPRS = COM3, COM4	Disabled	COM2
Sedona = COM3	None	COM1	COM2
Sedona = COM3	RS-232 = COM4	COM1	COM2
Sedona = COM3	RS-485 = COM4, COM5	COM1	COM2
Sedona = COM3	LON = LON1	COM1	COM2
Sedona = COM3	GPRS = COM4, COM5	COM1	COM2
GPRS = COM3, COM4	None	COM1	COM2
GPRS = COM3, COM4	RS-232 = COM5	COM1	COM2
GPRS = COM3, COM4	RS-485 = COM5, COM6	COM1	COM2
GPRS = COM3, COM4	LON = LON1	COM1	COM2
GPRS = COM3, COM4	SEDONA = COM5	COM1	COM2

## Mounting Option Cards

For complete details, refer to the specific mounting and wiring guide that shipped with the option card. Follow these basic steps:

1. If a station is running, stop the station using the platform Application Director View.
  2. Remove power from the controller.
  3. Remove the optional battery and bracket assembly by taking out the four screws holding it in place. Set the screws aside for later. Unplug the battery from the connector on the FX30E/FX60E (if the battery is being used in addition to the integral SRAM for backup).
  4. Remove the blanking end plate for the slot into which you are installing the option card. Retain the blanking plate in case you need to remove the option card at a later time.
  5. Carefully insert the pins of the option card into the socket of the appropriate option card slot. The mounting holes on the option card should line up with the standoffs on the base unit. If they do not, the connector is not properly aligned. Press until the option card is completely seated.
  6. Place the custom end plate that came with the option card over the connector of the option card.
  7. Insert the battery connector plug into the battery connector on the FX30E/FX60E.
  8. Set the battery and bracket assembly back over the option card slots, with the mounting holes aligned with the standoffs.
  9. Place the four screws through the battery bracket, end plates, and into the standoffs on the FX30E/FX60E base unit. Hand-tighten these screws.
  10. Replace the cover.
  11. Restore power to the FX30E/FX60E.
3. Prepare power wiring (leave the unit powered off). See Power Wiring for details.
  4. Connect communications cables. See Communications Wiring for ports available on the FX30E/FX60E base unit. For ports on any installed option card (LON, RS-232, RS-485, modem, and WTC), refer to the specific mounting and wiring guide for additional details.
  5. If NDIO modules are installed, connect the I/O wiring. Refer to the appropriate mounting and wiring guide for complete details.
  6. Apply power to the unit. See Powerup and Initial Checkout.

## Grounding

An earth ground spade lug (0.187 in. [4.75 mm]) is provided on the base of the FX30E/FX60E for connection to earth ground. For maximum protection from electrostatic discharge or other forms of electromagnetic interference, connect the supplied earth grounding wire to this lug and a nearby earth ground (Figure 9). Keep this wire as short as possible.

Power is provided for the FX30E/FX60E plug-in accessory modules through the 30-pin accessory connectors; however, connect the earth ground spade lug of each accessory module to ground in the same manner.

## Power Wiring

The FX30E/FX60E must be powered by an approved 15 VDC power source. This source can come from one of the following:

- a DIN rail mount 24 VAC/DC powered module (LP-FXPM24-0)
- a DIN rail mount line voltage (120-240 VAC) module (LP-FXPM263-0)
- an external Class 2 wall mount AC adapter (LP-FXPMUS/EU/UK-0)

The FX30E/FX60E does not include an on/off switch. To apply power, you can do one of the following:

- plug in the power connector to the FX30E/FX60E, if the wall mount power module is used
- plug in its 2-position power connector, if the 24 VAC DIN rail power supply is used
- energize the AC circuit (120-240 VAC) wired to that module, if the line voltage DIN rail power supply is used

## Wiring

See Figure 8 to locate connectors and other components on the FX30E/FX60E. Make connections to the FX30E/FX60E in the following order.

1. Install any option cards (LON, RS-232, RS-485, modem, WTC) in Option Slots 1 and 2. See Mounting Option Cards for the general procedure. For complete details, refer to the specific mounting and wiring guide that shipped with the option card.
2. Connect the supplied earth grounding wires (with spade connector) from the earth ground lug on the FX30E/FX60E and any accessory modules (if used) to a nearby earth grounding point. See Grounding for details.



**Risk of Property Damage.** Do not apply power to the system before checking all wiring connections. Short circuited or improperly connected wires may result in permanent damage to the equipment.

**MISE EN GARDE: Risque dégâts matériels.** Ne pas mettre le système sous tension avant d'avoir vérifié tous les raccords de câblage. Des fils formant un court-circuit ou connectés de façon incorrecte risquent d'endommager irrémédiablement l'équipement.

If desired, you can use the wall mount power adapter in your office to initially commission the FX30E/FX60E, and then install the DIN rail mount power supply at the project site.

**Important:** Do not connect both the LP-FXPMUS and LP-FXPM24 supplies at the same time, or equipment damage may result.

### Wall Mount Power Module

Three models of wall power modules are available: United States (U.S.), European Union (EU), and United Kingdom (U.K.). All are self-contained, isolated switching power supplies designed to plug into a standard building power receptacle for appropriate voltage. To supply power to the FX30E/FX60E, you simply plug the barrel connector plug from the power module into the barrel power connector on the FX30E/FX60E base unit.

**Important:** Do not plug the barrel connector plug from the power module into the FX30E/FX60E until all other mounting and wiring is completed.

### Wiring LP-FXPM24-0 Power Module

The LP-FXPM24-0 module lets you power the FX30E/FX60E (and, if installed, the NDIO16 modules) from a dedicated, Class 2, 24 VAC transformer, or from a 24 VDC power supply. If installing NDIO16 modules, install the power module as the last (end) module in the chain. See [Figure 5](#).

**Important:** If powering from a 24 VAC transformer, do not power any other equipment with it. Otherwise, conducted noise problems may result. Also, do not ground either side of the transformer's secondary.

Located at the bottom of the power module are a 2-position power connector and an earth ground spade lug. Connect the supplied earth ground wire to a nearby earth ground point. Unplug the power connector plug from the module and make connections to it.



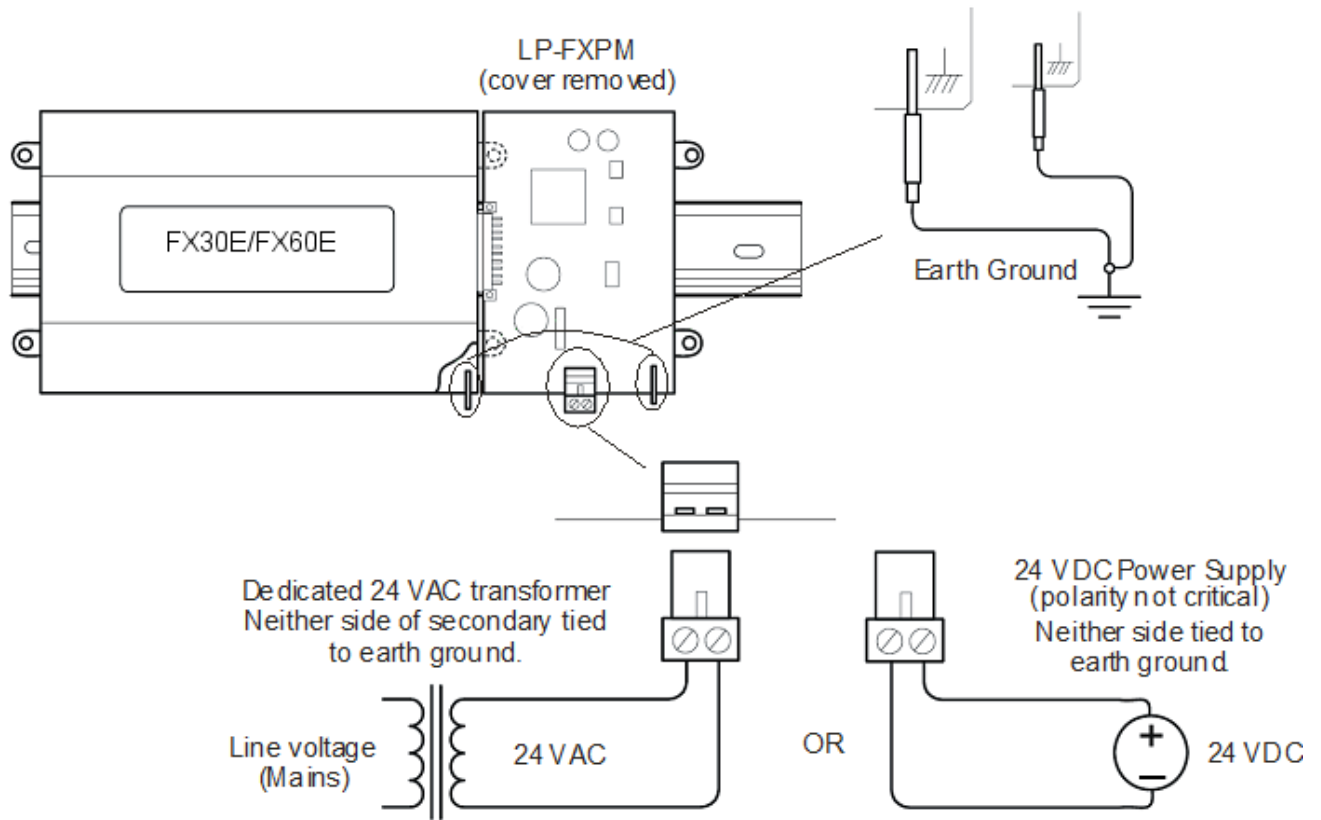
**Risk of Property Damage.** Do not apply power to the system before checking all wiring connections. Short circuited or improperly connected wires may result in permanent damage to the equipment.

**MISE EN GARDE: Risque dégâts matériels.** Ne pas mettre le système sous tension avant d'avoir vérifié tous les raccords de câblage. Des fils formant un court-circuit ou connectés de façon incorrecte risquent d'endommager irrémédiablement l'équipement.

Power consumption depends on installed accessories and option cards, and may vary from:

- FX30E/FX60E with power module alone: approximately 7.5 VA (AC) or 7.5 W (DC)
- FX30E/FX60E with power module and 4 NDIO modules, plus option cards: up to 20 VA (AC) or 20 W (DC)

**Figure 8: LP-FXPM Power Module Wiring Connections**



## LP-FXPM263-0 Line Voltage Power Module

You can power the FX30E/FX60E using the LP-FXPM263-0 module (and, if installed, the NDIO16 modules) from AC line power, with a universal input range from 120-243 VAC. If installing NDIO16 modules, install the power module as the last (end) module in the chain ([Figure 5](#)).

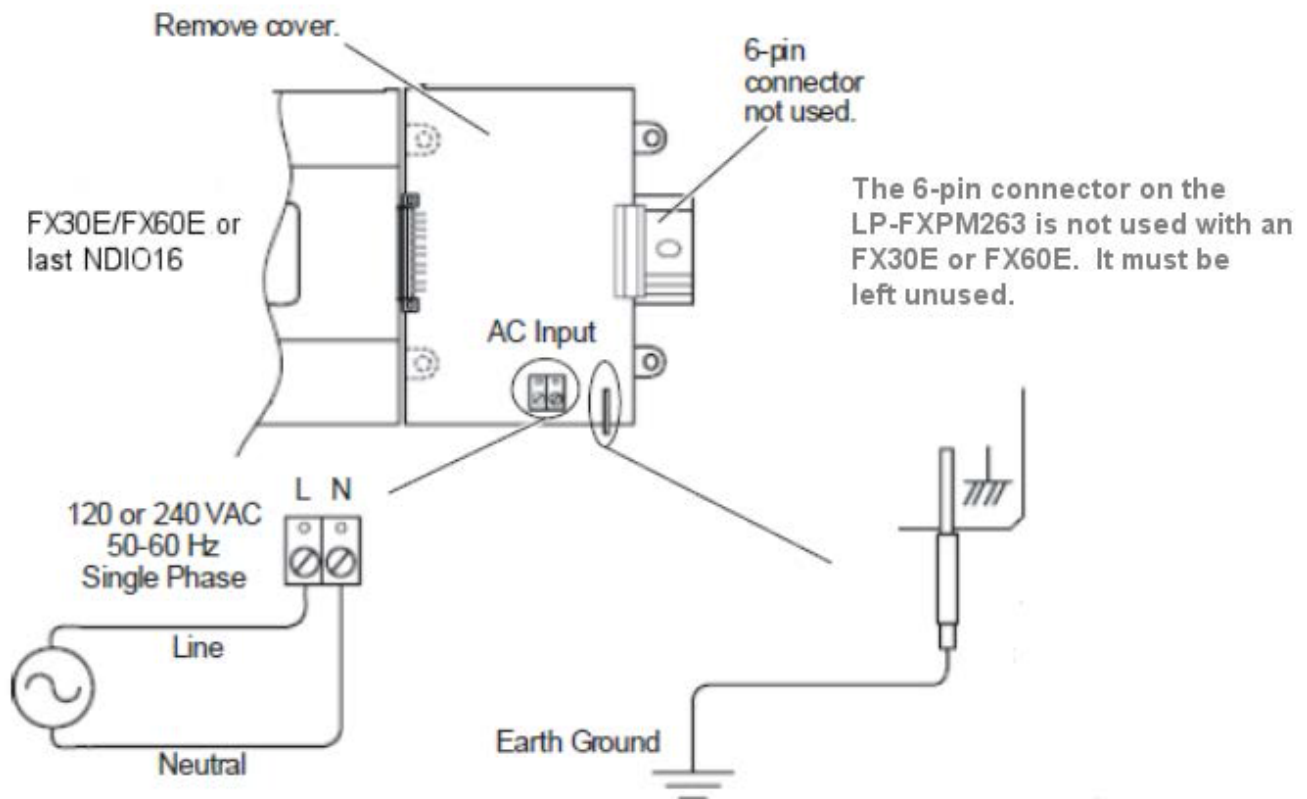
### WARNING

**Risk of Electric Shock.** Disconnect power supply before making electrical connections. Contact with components carrying hazardous voltage can cause electric shock and may result in personal injury or death.

**AVERTISSEMENT: Risque de décharge électrique.** Débrancher l'alimentation avant de réaliser tout branchement électrique. Tout contact avec des composants conducteurs de tensions dangereuses risque d'entraîner une décharge électrique et de provoquer des blessures graves, voire mortelles.

**Note:** The 6-pin connector of the LP-FXPM263-0 is not used with a FX30E/FX60E.

**Figure 9: LP-FXPM263-0 Line Voltage Power Module Wiring Connections**



## Wiring the DIN Rail Mount Line Voltage Power Module

To wire the DIN rail mount line voltage power module, see Figure 9 and follow these instructions:

1. Remove power from the AC circuit being wired to the power module.
2. Remove the power module cover by pressing in the four tabs on both ends of the unit, and lifting the cover off. If the power module is plugged into the FX30E/FX60E or an NDIO16, you may need to slide it away to access the cover tabs.
3. Connect the supplied earth grounding wire to a nearby grounding point ([Figure 9](#)).
4. Make AC circuit connections line (mains) and neutral to the terminals labeled INPUT PWR.
5. Replace the cover on the power module.
6. Make sure that all modules in the assembly are firmly connected together and secured.



**Risk of Property Damage.** Do not apply power to the system before checking all wiring connections. Short circuited or improperly connected wires may result in permanent damage to the equipment.

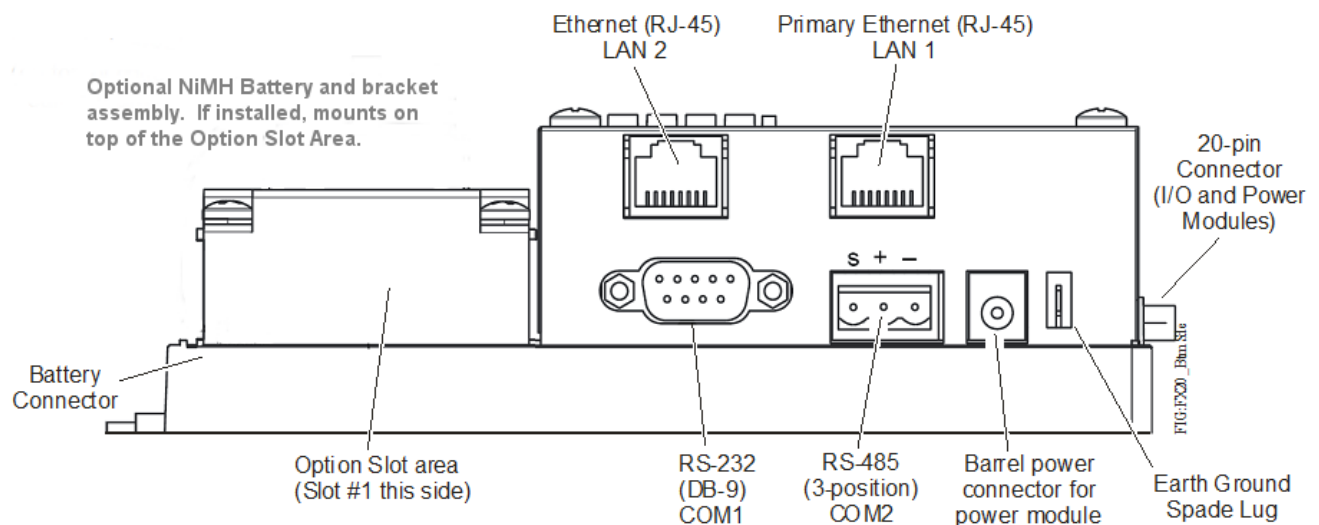
**MISE EN GARDE: Risque dégâts matériels.** Ne pas mettre le système sous tension avant d'avoir vérifié tous les raccords de câblage. Des fils formant un court-circuit ou connectés de façon incorrecte risquent d'endommager irrémédiablement l'équipement.

## Communication Wiring

Connect communications wiring to the ports on the bottom of the FX30E/FX60E.

**Note:** Prior to connecting cables, provide strain relief for them to prevent damage to the controller.

**Figure 10: FX30E/FX60E Bottom Side (Cover Removed)**



## Ethernet Port

Two female 10/100-Mbit Ethernet connections are provided on the FX30E/FX60E. These connections are capable of running at either 10 Mbps or 100 Mbps; the controller automatically adjusts to either speed. This means the FX30E/FX60E can exist on the same network with a mixture of 10BaseT and 100BaseTX hardware connected to a smart 10/100 hub capable of adjusting to the devices it supports.

Two RJ-45 connectors labeled LAN1 and LAN2 are provided for the Ethernet connections (Figure 9). Use a standard Ethernet patch cable for connecting to a hub or Ethernet switch. An activity LED for each Ethernet port is visible, labeled LAN1 and LAN2 on the cover.

The factory-default IP address for LAN1 is 192.168.1.149. By default, LAN2 is disabled.

**Note:** Typically, you only use LAN1 (primary port). If you have a specific application for isolating a driver's network traffic to a separate local area network (LAN), you can use LAN2. **Do not** use LAN2 as the primary port.



## Serial Ports

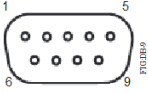
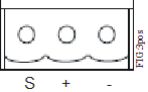
The FX30E/FX60E has two serial ports (Figure 10). Each port has a Universal Asynchronous Receive Transmit (UART) capable of operating up to 115,200 baud. The left port is an RS-232 port that requires a DB-9 male plug connector. The right port is a non-isolated RS-485 port that uses two wires with a shield connection and a screw-terminal connector plug.

**Note:** A green receive LED and yellow transmit LED are provided for each serial port. These LEDs are located on the bottom board opposite of the serial connectors (Figure 7). The LEDs are labeled on the board (COM1, COM2) and are not visible with the cover on.

## RS-232 Port

An RS-232 serial port uses a DB-9 male connector and always operates as COM1. You can use a standard DB-9 serial cable with this port. The FX30E/FX60E is a serial Data Terminal Equipment (DTE) device, so connecting another DTE device (computer) requires a null modem cable. To connect the FX30E/FX60E to a Data Communication Equipment (DCE) device (modem), use a straight-through cable. Table 4 provides the standard serial DB-9 pinouts.

**Table 4: Serial Port Pinouts**

Pinout References	Signal	DB-9 Plug Pin	Base RS-485 Port (COM2) Pinouts
DB-9 Plug (Male) 	DCD	Data carrier detect	
	RXD	Receive data	
	TXD	Transmit data	
	DTR	Data terminal ready	
	GND	Ground	
	DSR	Data set ready	
	RTS	Request to send	
	CTS	Clear to send	
	Not used on the FX30E/FX60E		

## RS-485 Port

An RS-485 non-isolated port uses a 3-position, screw terminal connector and always operates as COM2. Use shielded 18-22 AWG wire for this connector (refer to the Telecommunications Industry Association/Electronic Industries Alliance [TIA/EIA-485 standard]). As shown in Table 4, the screw terminals (from left to right) are shield, plus (+), and minus (-).

### RS-485 Biasing

The FX30E/FX60E's RS-485 port has a pair of 2-pin jumpers that can be shorted with jumper blocks to provide **biasing**. When shipped from the factory, these pins are not shorted and therefore, the RS-485 port is unbiased.

Biasing can improve RS-485 communications by eliminating indeterminate idle states. When you install two, 2-pin shorting blocks on the controller's RS-485 bias jumper pins, the shorting blocks add two onboard 3.3K ohm resistors into the controller's RS-485 circuit, as follows:

- from RS-485 plus (+) to 5 V
- from RS-485 minus (-) to ground

**Note:** Only one device on an RS-485 trunk should be biased. Otherwise, undue loading of the circuit may result with fewer devices supported.

**Note:** RS-485 bias resistors are different than termination resistors, externally installed at the two physical ends of a daisy-chained RS-485 trunk, across the plus (+) and minus (-) terminals. Termination resistors are typically 100 or 120 ohm value resistors.

**Note:** If termination resistors are used, RS-485 biasing is typically required.

## Adding RS-485 Bias

To add biasing, power off the FX30E/FX60E and remove the necessary assemblies (such as metal shield) to access the base board jumper pins located behind the RS-485 port. Then reposition the two shorting blocks on these jumper pins and reassemble the unit by remounting the processor module, hex standoffs, metal shield, and shield screws.

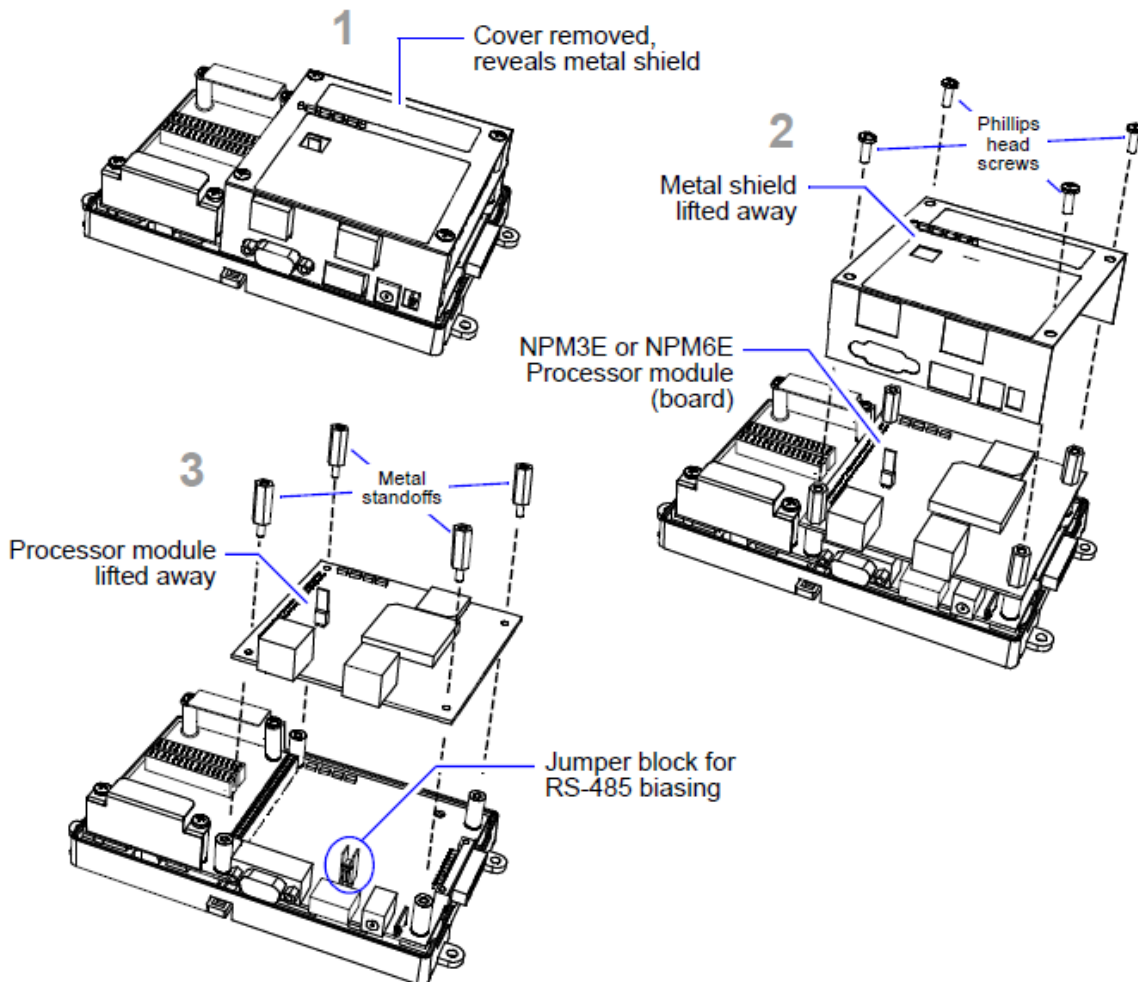
### **WARNING**

**Risk of Electric Shock.** Disconnect the power supply before making electrical connections. Contact with components carrying hazardous voltage can cause electric shock and may result in personal injury or death.

**AVERTISSEMENT: Risque de décharge électrique.** Débrancher l'alimentation avant de réaliser tout branchement électrique. Tout contact avec des composants conducteurs de tensions dangereuses risque d'entraîner une décharge électrique et de provoquer des blessures graves, voire mortelles.

If the controller is already installed or mounted, we recommend that you remove the controller first. Then work on a flat, stable, well lit work surface.

**Figure 11: Basic Stages of Controller Disassembly**



## Disassembling the Controller

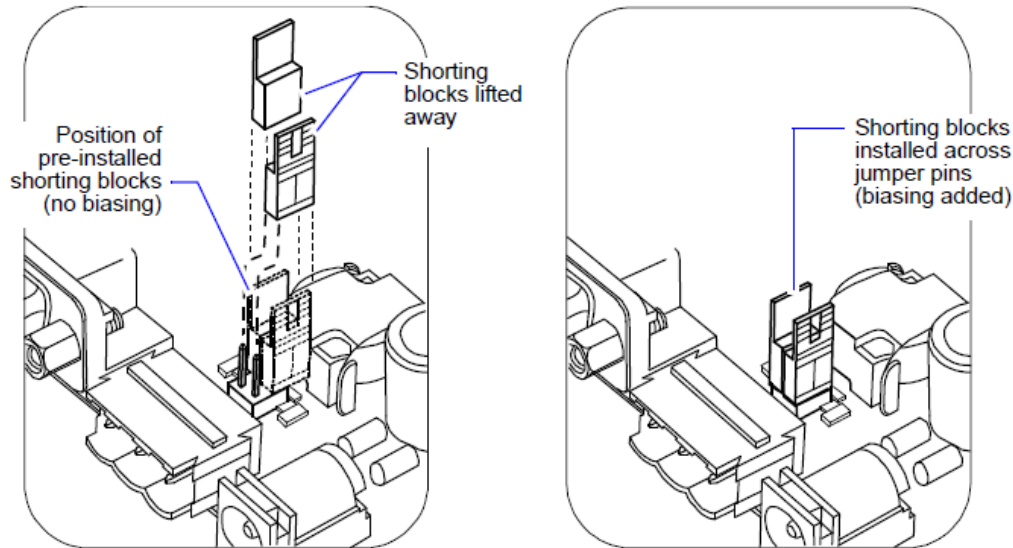
1. Remove power from the controller.
2. Remove the plastic cover.
3. With a Phillips head screwdriver, remove the four screws that secure the metal shield, and set the screws aside.
4. Remove the metal shield. Carefully pry the shield up from the top (hole vented side) first and then push out the other side to slip the port holes past the port edges. Then lift the shield up and away. Set shield aside.

**Note:** Be mindful of the side clips on the controller's two Ethernet ports.

5. Use a 1/4 in. (7 mm) nut driver to unscrew the four metal standoffs, and set them aside.
6. Carefully pry up the FX30E/FX60E module board, noting that the two-row, 50-pin connector is on the option card side. Keep the board level as you work it loose from this connector.

Set the processor module board aside. Note the jumper block on the base board behind the RS-485 port.

**Figure 12: Installing Shorting Blocks across Both Sides of Jumper Block**



## Installing Shorting Blocks to Add RS-485 Biasing

1. Locate the four jumper pins behind the RS-485 port, with 2-pin shorting blocks installed on one pin each.
2. To add biasing, remove and replace both shorting blocks back onto the jumper pins.

## Reassembling the Controller

1. Carefully replace the processor module board onto the 50-pin connector, with its corner mounting holes aligned on the four lower standoffs. Press down on the connector to fully seat the board.
2. Refasten the four metal hex standoffs by hand tightening with a 1/4 in. (7 mm) nut driver.
3. Replace the shield back onto the unit. Carefully ease the shield over the port side first and then spring it down over the other side. Make sure that the shield's corner holes align with the metal standoffs.
4. With a Phillips head screwdriver, refasten the four screws that secure the shield to the standoffs.

5. Replace the plastic cover onto the unit.

## Setup and Adjustments

### Default Communication and Login Properties

The new FX30E/FX60E is pre-configured with default properties as defined in [Table 5](#).

**Table 5: FX30E/FX60E Default Properties**

Name	Default Property
Internet Protocol (IP) Address	192.168.1.149
Subnet Mask	255.255.255.0
Default Gateway	192.168.1.1
Remote User Name	jci
Remote Password	explorer

## Powerup and Initial Checkout

Ensure that power wiring to the transformer is complete before you proceed.

After you have completed all mounting and wiring steps:

1. Do one of the following:
  - Insert the power plug into either the 24 VAC/DC power module, or if using a wall adapter, the FX30E/FX60E.
  - Energize the 120–240 VAC circuit wired to the module, if using the line voltage power supply module.
2. Apply power.

**Important:** Do not connect both the wall power module and the DIN rail power modules at the same time, or equipment damage will result, or a power outage may go unrecognized.

## Backup Configurations

An FX30E/FX60E allows two separate and configurable methods to preserve unsaved station data when power quality events occur, including loss of primary power or low-voltage dips (brownout):

- Using the integral Static RAM (SRAM) on the FX30E/FX60E.  
This default method allows the unit to operate **battery-less** (without installing the optional NiMH battery pack). Note in this configuration, a reboot is likely to occur when a power outage or voltage dip is sustained for more than one AC line cycle (1/50th or 1/60th of a second) or a number of line cycles, depending on the load and power supply. Critical station data already is saved prior to any power quality event, but the NiMH battery option is available to prevent nuisance controller reboots during extended or frequent power outages.
- Using an optional on-board NiMH battery pack.  
Connecting the optional battery allows the controller to continue operation (without rebooting) over short power outages or brownouts lasting several seconds (or if also using SRAM, up to 10 minutes). For longer duration outages, the battery allows the controller to perform a controlled shutdown, safely backing up the station before shutting down.

The FX30E/FX60E can use both the NiMH backup battery and available SRAM for backup protection. Configuring for both backup battery and SRAM support provides the most comprehensive backup protection. This configuration allows the

FX30E/FX60E to handle brief power outages, while also protecting against a weak or aged battery.

## SRAM

The FX30E/FX60E includes an on-board SRAM and associated circuitry, allowing battery-less operation. A separate SRAM option card is not needed (or supported) in an FX30E/FX60E controller.

The default station backup configuration is to use SRAM, via the platform DataRecoveryService, which is automatically created in the FX30E/FX60E's running station. However, in some cases, a station may be a poor candidate for SRAM support, requiring too many resources by the associated platform service (for example, a station with many rapidly changing values all captured as histories, on change of value). In this case, you may need to disable SRAM support, and install and use only the optionally included NiMH battery pack.

## NiMH Battery Pack

Use the custom 10-cell NiMH (nickel metal hydride) battery assembly (included with the product) as an alternative to, or with, the SRAM backup method.

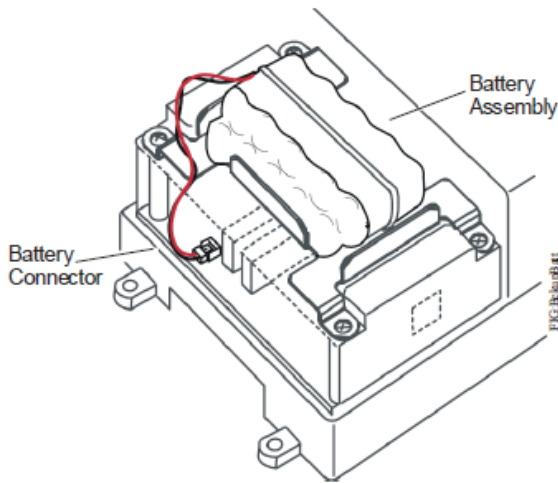
This battery allows the controller to continue station operation through short power bumps, ranging from a few seconds to a minute or more in duration (up to 10 minutes, if also using SRAM). If the controller experiences a longer outage, the NiMH battery provides enough run time for the unit to backup data and then shutdown. Shutdown occurs automatically, after data is backed up to on-board flash memory.

The FX30E/FX60E charges the battery during normal operation, until the controller is fully charged. Typically, the charge operation completes within 18 hours. Following a power outage, the battery is charged again, as necessary. The power and battery circuitry is monitored by a station running on the FX30E/FX60E (via its PowerMonitorService). Station alarms are generated when primary power is lost, or if the battery is uncharged or unable to hold a sufficient charge.

## Connecting the Backup Battery

With the cover removed from the FX30E/FX60E, locate the red and black wires with a plug on the backup battery. Insert the plug into the battery connector on the bottom board.

Figure 13: Backup Battery Connector Location



The connector is keyed so you cannot insert it incorrectly. The red (positive) connection should be the furthest from the two 30-pin option board connectors.

**Note:** A NiMH battery characteristic is to lose charge if not left in charge mode (trickle charge). Leaving the battery unconnected, or in the unit powered off causes the battery to fully discharge in a matter of weeks. Note that a new NiMH battery may be partially discharged. Therefore, allow at least 18 hours for a new battery to charge if it has not been in a powered unit.

The NiMH battery assembly should be replaced approximately every three years or more often if the unit is in a high temperature environment.

### Enabling Battery Only Backup Service

If a station is not compatible with SRAM support and you want to use the optional backup battery instead of the onboard SRAM, connect the optional NiMH battery pack to the FX30E or FX60E.

In the station's DataRecovery-Service, set the **Service Enabled** property to **false**. In the station's PlatformServices, make sure the **Battery Present** property is **true**.

## Status LEDs

### Checking the Status LEDs

When power is applied, the green LED labeled **Status** is lit. This LED status indicates that the system is normal and power is applied. Once the FX30E/FX60E boots, the yellow **BEAT** (heartbeat) LED begins to blink, with a typical rate of about one blink per second. Blinking should begin within 30 seconds after power is applied.

If, after applying power, the STATUS LED goes out, or the BEAT LED comes on steady and stays lit for longer than 2 minutes, contact your technical support representative for assistance. See also Using Status LEDs.

### Using Status LEDs

The FX30E/FX60E includes several LEDs that can help determine the status of the unit. These LEDs include:

- Ethernet Ports
- Heartbeat
- Status
- Serial Ports

See Figure 7 for the location of the status LEDs.

### Ethernet Ports LEDs

Each Ethernet port has one green LED, visible on the top cover. A LAN# LED indicates activity on that port as follows:

- **Off:** No Ethernet link is established.
- **On:** Ethernet link is established, but no activity is on the LAN.
- **Blinking:** Ethernet link is established with data activity on the LAN.

### Heartbeat LED

The yellow BEAT LED is located to the right of the Ethernet status LEDs. Under normal operation, this LED should blink about once per second. If the BEAT LED stays on constantly, does not light, or blinks very fast (more than once per second), contact your technical support representative for assistance.

**Important:** During boot-up, the heartbeat LED blinks in a 90% on, 10% off pattern. **Do not remove** power during this time, or data loss may result (NDIO module's firmware upgrade may be in progress).

## Status LED

The green Status LED is located to the right of the heartbeat (BEAT) LED. This LED provides a central processing unit (CPU) machine status check, and remains lit whenever the FX30E/FX60E is powered. If the Status LED does not light while power is applied, contact your technical support representative for assistance.

## Serial Port LEDs

LEDs for the two serial ports are located on the FX30E/FX60E's bottom board on the opposite side of the RS-232 and RS-485 ports (Figure 7). Labels **COM1** and **COM2** correspond to the software configuration of the COM ports. LEDs show, transmit, and receive activity for the serial ports and optional modem.

**Note:** You must remove the cover to see the serial port LEDs. See *Removing and Replacing the Cover*.

- The yellow Transmit LED indicates that the FX30E/FX60E is sending data out the serial port over a communications line to a connected device.
- The green Receive LED indicates that the FX30E/FX60E is receiving data from a connected device.

These LEDs are driven by pulse detectors that provide a fixed on-time sequence when data is detected on the port. If the receive LED is on constantly, a problem with the communications channel may be present, such as a shorted wire or reversed wiring.

## Niagara<sup>AX</sup> Software Installation

As shipped from the factory, the FX30E/FX60E is preconfigured with a Niagara build, a license, and Johnson Controls® specific Java® Archive (JAR) files. With these components in place, you only need to change login credentials and IP settings (per network requirements) when setting up the FX30E/FX60E. This section provides step-by-step instructions for these tasks.

To set up an FX30E/FX60E (and to upgrade to a newer Niagara build at a later date), use the Commissioning Wizard in the Platform/Platform Administration view.

**Note:** If you plan to update the JAR files with patches at a later date, use the Driver Upgrade Tool Commissioning Wizard or Software Manager in the Platform view. If you are changing login credentials, use the Change Remote Login Credentials menu item.

## Preparing for Setup

### Providing Power and Connectivity

Perform the initial startup of an FX30E/FX60E in your office before physically mounting it in place at a job site.

After you complete the commissioning process, mount and wire the FX30E/FX60E at the job site, making permanent mounting and wiring connections.

For this initial Ethernet connection, you can use one of the following:

- a crossover cable connected directly between your computer and the FX30E/FX60E
- a standard Local Area Network (LAN) connection in which your computer and the FX30E/FX60E are physically connected to the same Ethernet hub or switch

### IP Address

When shipped, a new FX30E/FX60E Series controller is pre-configured with an IP address of 192.168.1.149 and a default subnet mask of 255.255.255.0.

1. Use the Microsoft® Windows® Network Connections utility on your workstation to configure your Transmission Control Protocol (TCP)/IP settings with an IP address of 192.168.1.100 and subnet mask of 255.255.255.0.
2. Make an Ethernet connection to the FX30E/FX60E.
3. Run the FX Workbench application.
4. On the File Menu, click Open Remote Station.
  - a. Enter the Remote Site Address (**192.168.1.149**), Remote Platform User Name (**jci**), and Remote Password (**explorer**). Click OK.
  - b. When the Authentication dialog box appears, enter the Station User Name (**admin**), and password (**FacilityExplorer61**). Click OK.

At this point you are prompted to choose a strong password. A strong password consists of at least eight characters with at least one numeric and one alpha-numeric character. Be sure to guard and remember this password.

**Note:** Starting in Release 6.1, a blank (empty) password is not allowed. Further, if the UserService is configured for strong passwords (property Require Strong Passwords)—now the default—the password must be a minimum of eight characters, with at least one being a numeral (0-9) or any other special character, such as !, @, #, \$, or %.



- The station running on the FX30E/FX60E opens with the FX Workbench application, which has a Navigation Tree on the left and a Display Window on the right. In the Navigation Tree, open the Administration folder. Double-click the TCP IP Configuration option.
- On the TCP/IP Configuration screen, make sure the Interfaces field is expanded so that the IP Address and Subnet Mask fields appear. Modify the Gateway, IP Address and Subnet Mask fields, and click Save. When prompted to Reboot Now, click Yes. Give the FX30E/FX60E a couple of minutes to reboot and restart the station that is installed.

**Note:** If the following message appears, just click OK. The changes are saved anyway.



## Platform Daemon Credentials

An FX30E/FX60E Series controller is shipped with the following Platform Daemon (Administrator) credentials:

User Name: **jci**

Password: **explorer**

Initially, you use these default credentials to open a platform connection (log in) to the FX30E/FX60E. Like the factory-assigned IP address, default credentials are intended to be temporary. Change these credentials to be something unique, and **guard them closely**.

- Start the FX Workbench application.
- On the File Menu, click Open Remote Station. When prompted, enter the Remote Site Address (for example, 192.168.1.149), Remote Username (**jci**), and Remote Password (**explorer**). Click OK. When the Authentication dialog box appears, enter the Username (**admin**), leave the password field empty, and click OK.
- On the Tools menu, click Change Remote Platform Login Credentials. In the Change Remote Login Credentials dialog box, fill in the Username, Password, and Confirm Password fields, then click OK. The next time you log into the FX30E/FX60E, use these new credentials.

## Restoring a Backed Up Station

If the FX30E/FX60E ever gets into an erroneous condition where you cannot fix a station, you can restore a previously backed up station by using the Restore Backed Up Station menu item under the Tools menu.

- Run the FX Workbench application.
- On the File Menu, click Open Remote Station. When prompted, enter the Remote Site Address (for example, 192.168.1.149), Remote Platform User Name (**jci**), and Remote Password (**explorer**). Click OK. When the Authentication dialog box appears, enter the Station User Name (**admin**), Password (optional), and click OK.
- On the Tools menu, click Restore Backed Up Station. In the Restore Backed Up Station dialog box, enter the Remote Site IP Address, Remote Username, Remote Password, and select the .dist (station backup) file. Click OK. The FX30E/FX60E reboots automatically.

**Note:** You can back up a station by using the Backup Station menu item from the station node's popup menu in the Navigation Tree. We recommend that you back up a station daily to minimize the chance of information loss.

## Cleaning

If dust or metal filings are present inside the unit, clean with vacuum or compressed air. Otherwise, no cleaning inside the unit is required. Optionally, if the outer enclosure becomes dirty, you can wipe it with a damp cloth and mild detergent.

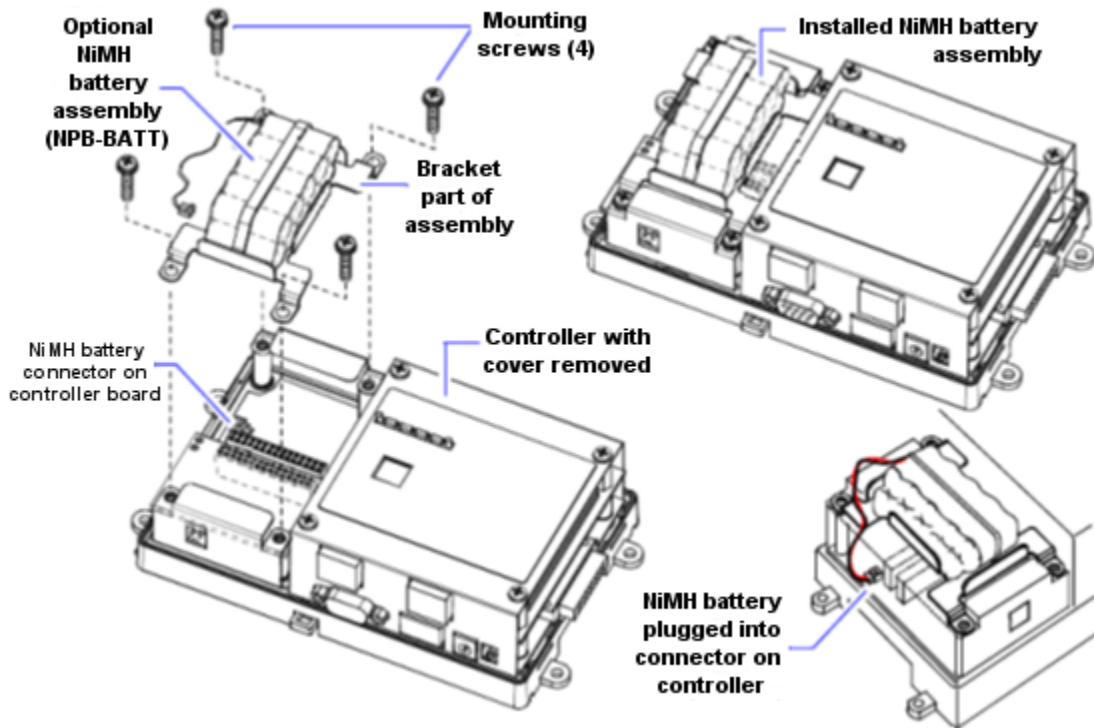
## NiMH Required Battery Installation Maintenance

### Installing or Replacing the Optional NiMH Battery

The optional NiMH battery pack is sold as an assembly. The NiMH battery is a custom battery pack with an attached cable and connector plug, mounted on a bracket. To install (or replace) the battery, you must remove power to the controller and remove its cover. Then you mount the battery assembly on top of the option card area.



Figure 14: Optional NiMH Battery Pack for FX30E/FX60E



## Installing or Replacing the Battery

**Important:** Use only NiMH battery packs approved for use with the FX30E/FX60E.

1. If you are replacing an existing battery in a controller not currently configured for SRAM usage, back up the FX30E/FX60E's configuration to your work using FX Workbench.
2. If a station is running, stop the station using the platform Application Director view.
3. Remove all power from the FX30E/FX60E. Wait for LED activity to stop (if a battery is already installed, this may take a minute or two).
4. Remove the cover. See *Removing and Replacing the Cover*. Note the Option Slot area where the NiMH battery assembly mounts.
5. If a battery assembly is already mounted, unplug the battery from the connector on the controller board. See Figure 13.
6. Remove the four screws that secure both option slot end plates (and if installed, the existing battery assembly bracket). Set the screws aside. Remove any existing battery assembly (if applicable).
7. Plug the battery connector plug of the new battery assembly into the battery connector on the controller. See Figure 13.
8. Set the new NiMH battery assembly on top of the option card slots, over the option card end plates. Ensure the bracket mounting holes are aligned with the standoffs.
9. Place the four screws through the battery bracket, option card end plates, and into the standoffs on the controller's base board. Using a screwdriver, hand-tighten the screws.
10. Replace the cover.
11. Restore power to the FX30E/FX60E and verify normal operation.

# Repair Information

Servicing the FX30E/FX60E may call for replacement parts.

## Non-replaceable Parts

Other than the parts listed in the Standard Replacement Parts section, no serviceable components are on the base assembly.

## Memory

Any addition, modification, or replacement of memory components requires software configuration changes and is not field upgradeable. For additional information on modifying the memory capacity of the FX30E/FX60E, consult your local sales representative.

## Fuse

The FX30E/FX60E contains a non-user replaceable fuse soldered on the circuit board. This fuse provides protection from internal shorts or connection to incorrect power supplies. If the fuse circuitry is suspect, contact your technical support representative for assistance.

## Standard Replacement Parts

Table 6: Standard Replacement Parts

Part Number	Description
LP-KITFX2BAT-0	NiMH Battery Pack: includes battery bracket (See Replacing the Battery.)

## New Replacement Unit

To replace a faulty FX30E/FX60E, order a new one. To ensure proper credit for a FX30E/FX60E still under warranty, contact the Johnson Controls Product Sales Operations Team for return authorization.

## Replacing an FX30E/FX60E

**Important:** Before handling circuit boards, discharge any accumulated static by touching the metal surface of the FX30E/FX60E.

1. Use FX Workbench to back up the FX30E/FX60E configuration to your computer.
2. Remove power to the FX30E/FX60E. The unit powers down automatically.  
**Note:** If NDIO accessory modules are installed, and any I/O points have voltage, turn the devices off or disconnect power from them.
3. Note the positions of all communications and other wiring cables going to the FX30E/FX60E, as well as all installed accessory modules (if they must be removed). If necessary, label connectors and accessory modules to avoid misconnection later when you are replacing the FX30E/FX60E.
4. Unplug all Ethernet, serial, LON, modem, and I/O connectors from the FX30E/FX60E.
5. Unplug the earth ground wire.
6. If an NDIO accessory module is installed:
  - a. If DIN rail mounting with DIN end clips were used, you may be able to remove the DIN rail end clip that secures the FX30E/FX60E end of the assembly and then slide the FX30E/FX60E away from the rest of the assembly. Then, remove the FX30E/FX60E from the DIN rail (see Figure 3), leaving the mounting and wiring of the NDIO modules untouched. Go to Step 5.
  - b. If tab (screw) mounting was used instead of DIN rail mounting, or if a combination of DIN rail mounting and tab screws were used, remove the accessory modules first, then remove the FX30E/FX60E. Carefully observe all wiring terminations, then unplug the I/O connector plugs and earth ground wires from the installed NDIO modules. Remove the installed accessory modules, starting with the end module. You can secure modules with screws through the mounting tabs or clipped to a DIN rail, or fastened by some combination. Remove any screws fastening the FX30E/FX60E and remove the FX30E/FX60E.
7. Remove the cover from the old FX30E/FX60E (see Removing and Replacing the Cover). Note the position of installed option boards, if any. You must transfer them to the replacement FX30E/FX60E.
8. Remove the option boards from the old FX30E/FX60E and install them into the replacement FX30E/FX60E, if applicable. See Mounting Option Cards.
9. Mount the replacement FX30E/FX60E as it was previously, using the same DIN rail location or screws.
10. Reconnect or remount any removed accessory modules, being careful to replace them in the same order, using the same DIN rail location or screws. Secure all accessory modules as done previously.
11. Reconnect the earth ground wires to the FX30E/FX60E grounding lug and any installed accessory modules.
12. Reconnect any Ethernet, serial, modem, and I/O connectors to the FX30E/FX60E and any installed accessory modules.
13. If using NDIO modules, and if any of your I/O points have voltage, turn on the devices or reconnect power to them.

14. Restore power to the FX30E/FX60E. To verify operation, see Checking the Status LEDs.
15. Use FX Workbench to recommission the FX30E/FX60E and install the saved station database.



**Building Efficiency**  
507 E. Michigan Street, Milwaukee, WI 53202

*Johnson Controls® is a registered trademark of Johnson Controls, Inc.  
All other marks herein are the marks of their respective owners. © 2015 Johnson Controls, Inc.*