

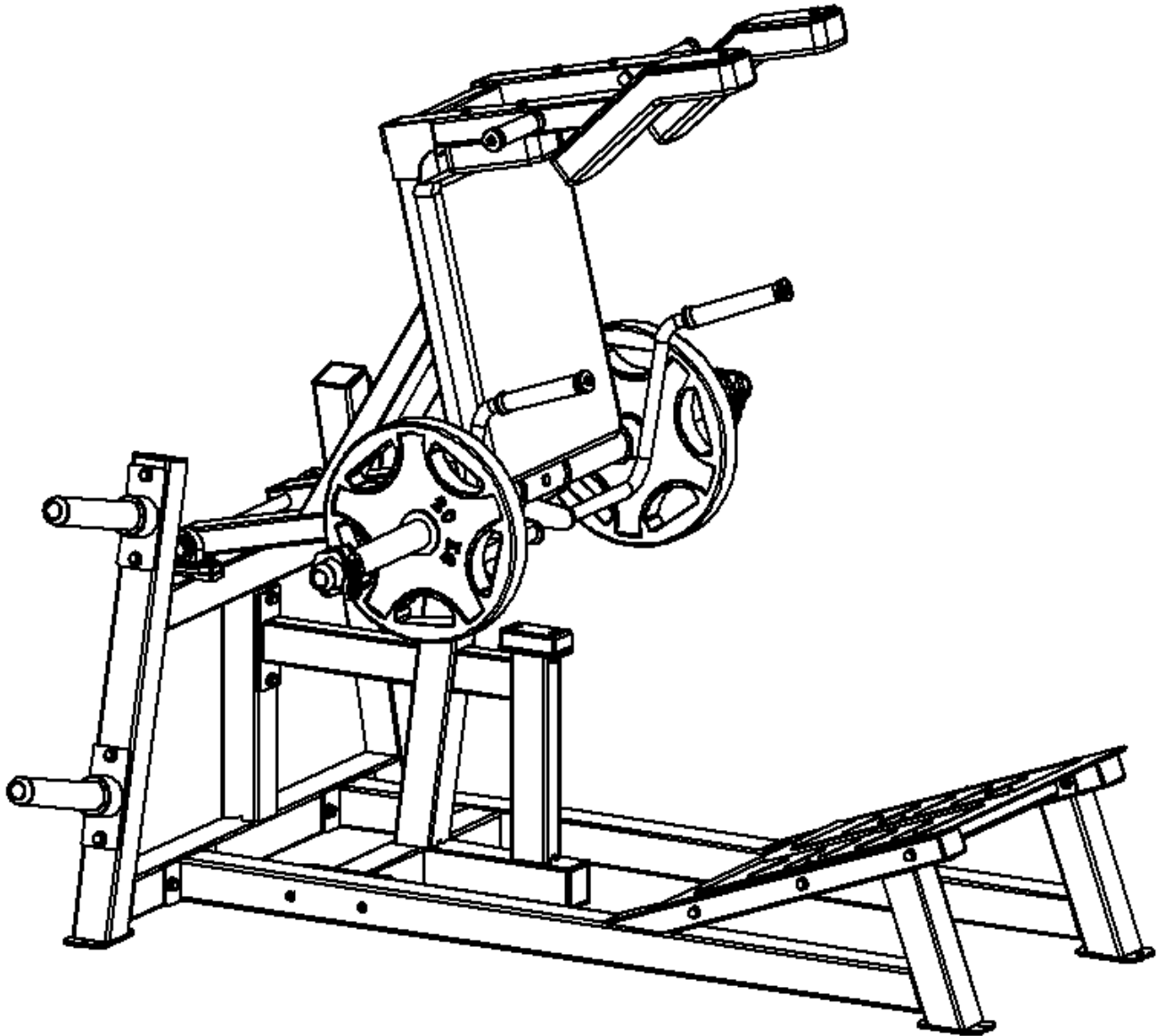

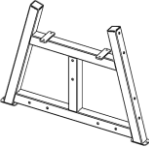







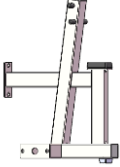
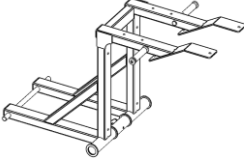



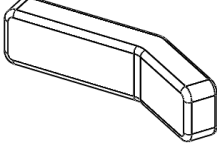

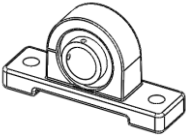
EXP-5061 Power Squat
Installation Standard Instructions

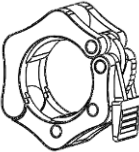

Parts list (Individually packaged)

					
NO.1	Rear bracket welding assembly*1pc	NO.2	Underframe welding assembly*2pcs	NO.3	Foot pedal welding assembly*1pc
					
NO.4	Limit assembly*1pc	NO.5	Large movable arm assembly*1pc	NO.6	Hook welding assembly*1pc
					
NO.7	Barrel welding assembly*4pcs	NO.8	Shoulder pads*2pcs	NO.9	Bending shoulder pad*2pcs
					
NO.10	Large backrest*1pc	NO.11	Bearing holder*2pcs	NO.12	Stainless steel components*1pc
					
NO.13	New sheath*2pc	NO.14	Lock Jaw Collar*2pcs	NO.15	Pipe plug*6pcs

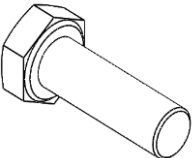
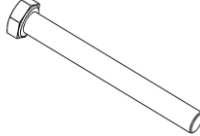
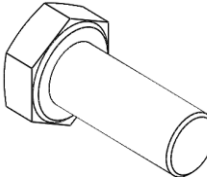
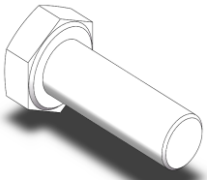
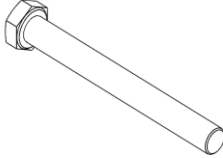
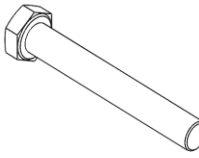
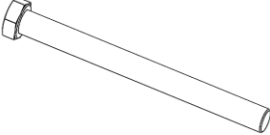
Blister pack screw schedule

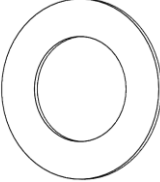
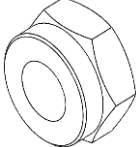
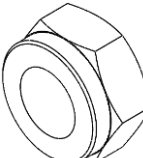
					
A	M8*25 external hexagonal screws*4pcs	B	M8*75 Hexagon socket screws*8pcs	C	M10*25 Hexagon socket screws*18pcs
					
D	M10*30 Hexagon socket screws*4pcs	E	M10*95 Hexagon socket screws*6pcs	F	M10*75 Hexagon socket screws*1pc
					
G	M16*180 Hexagon socket screws*1pc	H	Φ10 spacer*29pcs	I	Φ8 spacer*12pcs
					
J	Φ16 spacer*1pc	K	M10 Locknut*7pcs	L	M16 Locknut*1pc

Assembly steps

Step NO	Item NO	Name	Quantity	Item NO	Name	Quantity
1	NO.1	Rear bracket welding assembly	1	C	M10*25 Hexagon socket screws	10
	NO.2	Underframe welding assembly	2	H	Φ10 spacer	10
	NO.4	Limit assembly	1			

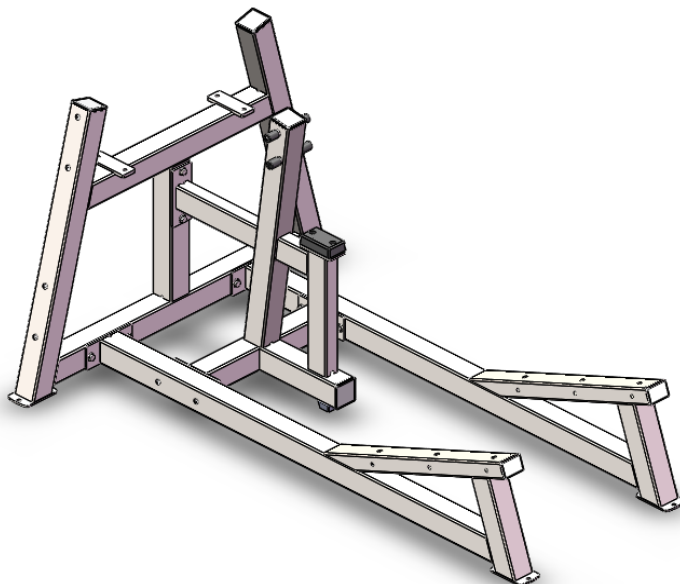
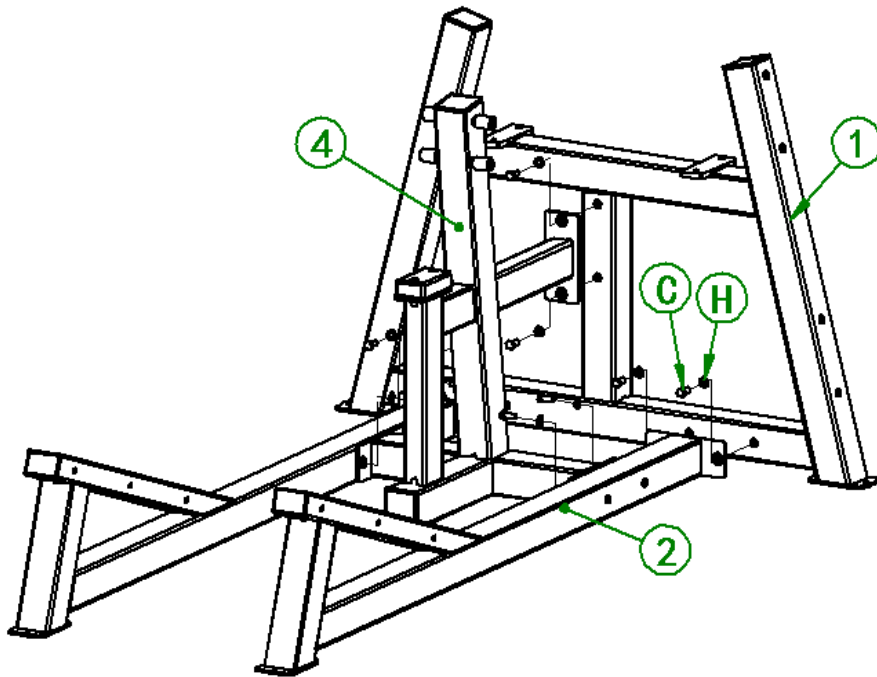

NO.1 Rear bracket welding assembly*1pc

Step NO	Item NO	Name	Quantity	Item NO	Name	Quantity
	NO.16	75*75 pipe plug	2			
	NO.17	M10 pull rivet	14			

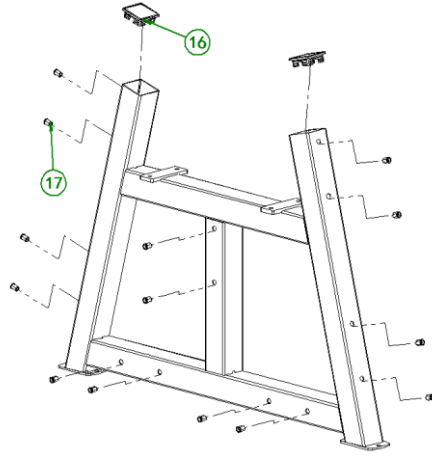

NO.2 Underframe welding assembly*2pcs

Step NO	Item NO	Name	Quantity	Item NO	Name	Quantity
	NO.18	50*75 pipe plug	1			
	NO.17	M10 pull rivet	4			

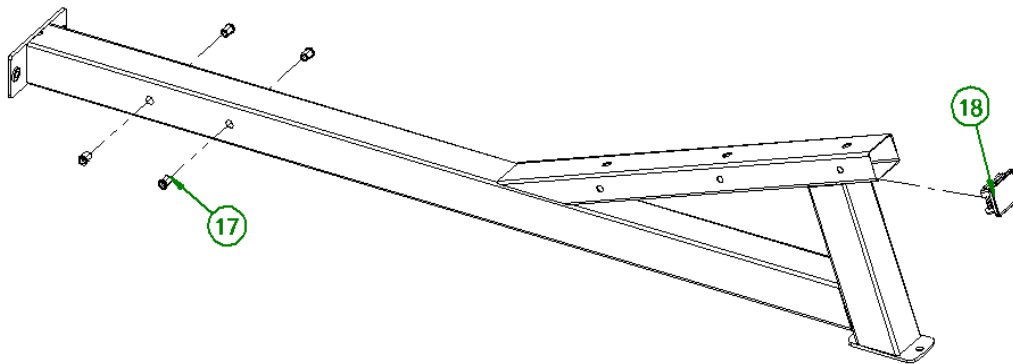

NO.4 Limit assembly*1pc

Step NO	Item NO	Name	Quantity	Item NO	Name	Quantity
	NO.16	75*75 pipe plug	2	21	M8 pull rivet nut	2
	NO.23	Smith Sheathing	4	19	Shock pad 2	1
	NO.22	Shock pad 1	1	M	M8X30 cylindrical head screws	2
	P	M5X10 flat countersunk head screws	4	N	M10*25 cylindrical head screws	2

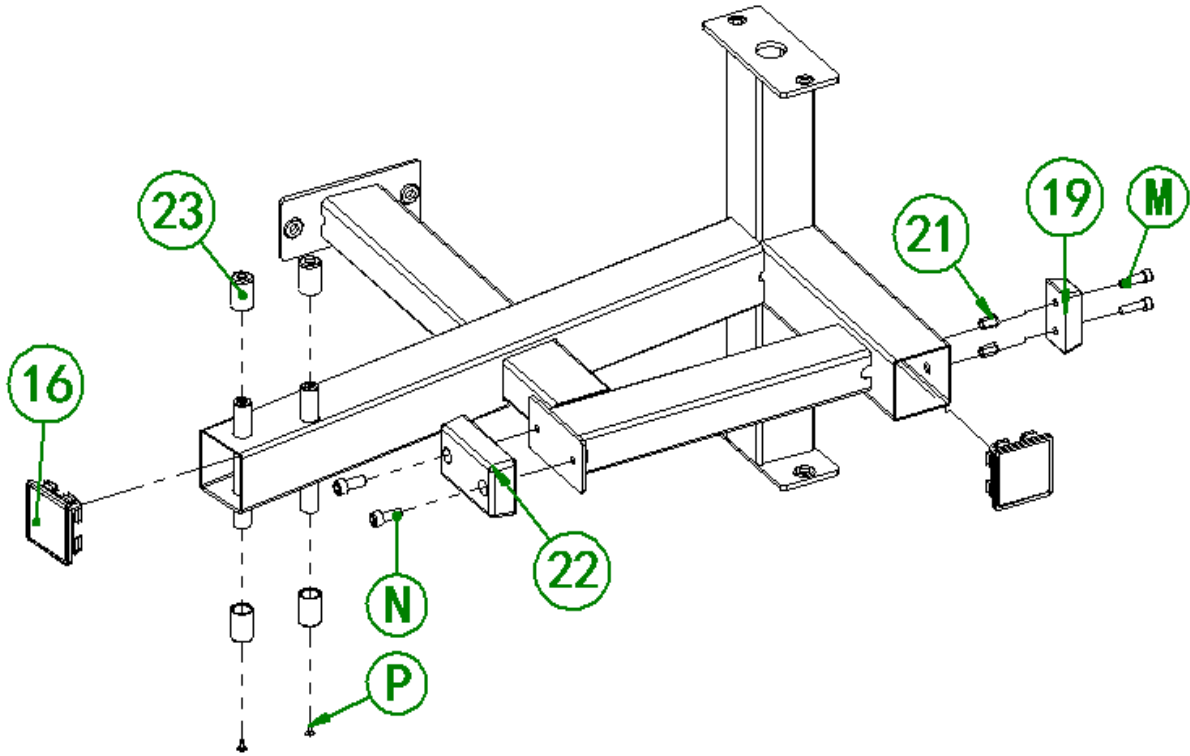

NO.5 Large movable arm assembly*1pc

Step NO	Item NO	Name	Quantity	Item NO	Name	Quantity
	NO.18	50*75 pipe plug	4	R	M5*6 top wire	4
	NO.24	Φ25 round pipe plug	2	Q	M8 star nut	2
	NO.25	handle rubber	2	S	M8 25 flat countersunk head screws	2
	NO.26	End front cover	2	NO.29	Aluminum back cover	2

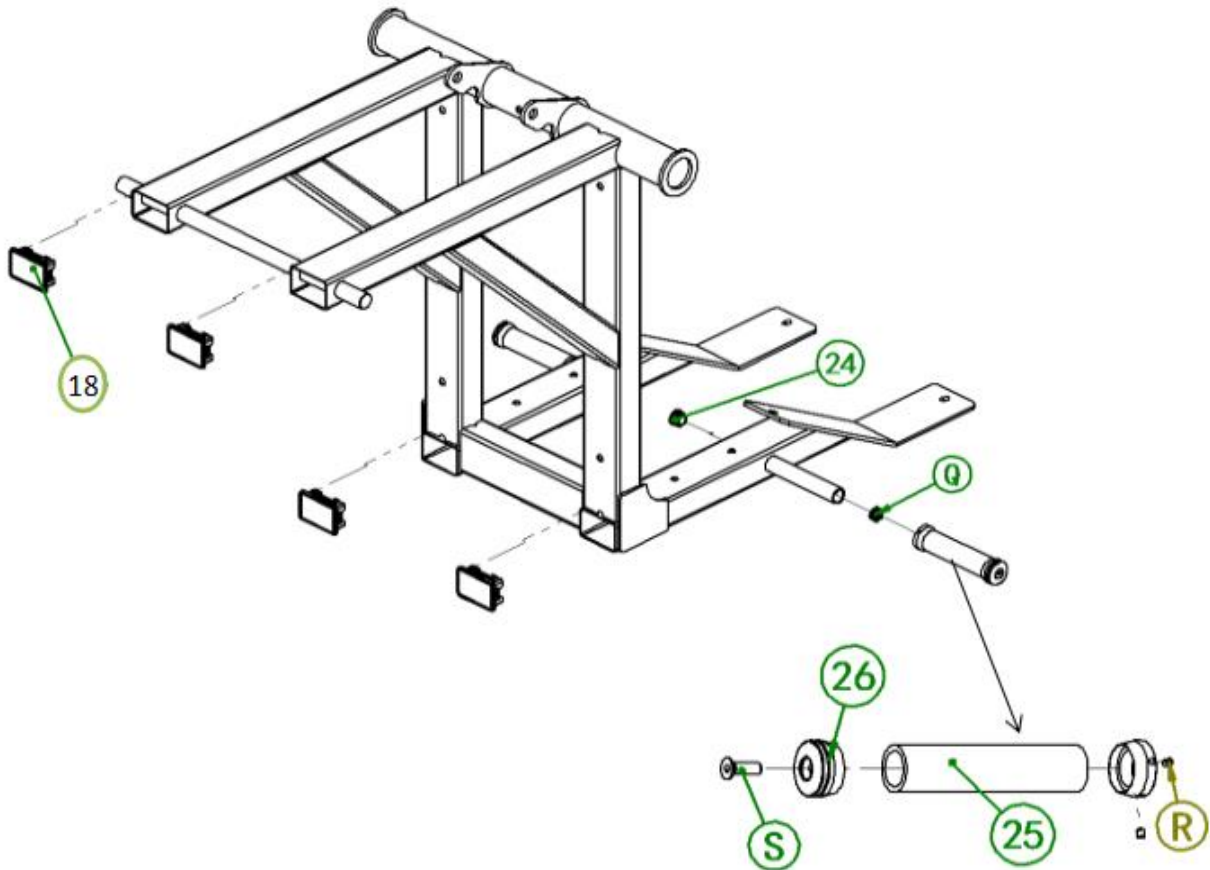

Assembly steps

Step NO	Item NO	Name	Quantity	Item NO	Name	Quantity
2	NO.5	Large movable arm assembly	1	G	M16*180 Hexagon socket screws	1
	NO.6	Hook welding assembly	1	J	Φ16 spacer	1
	NO.7	Barrel welding assembly	4	L	M16 Locknut	1
	C	M10*25 Hexagon socket screws	8	D	M10*30 Hexagon socket screws	4
	NO.11	Bearing holder	2	H	Φ10 spacer	12

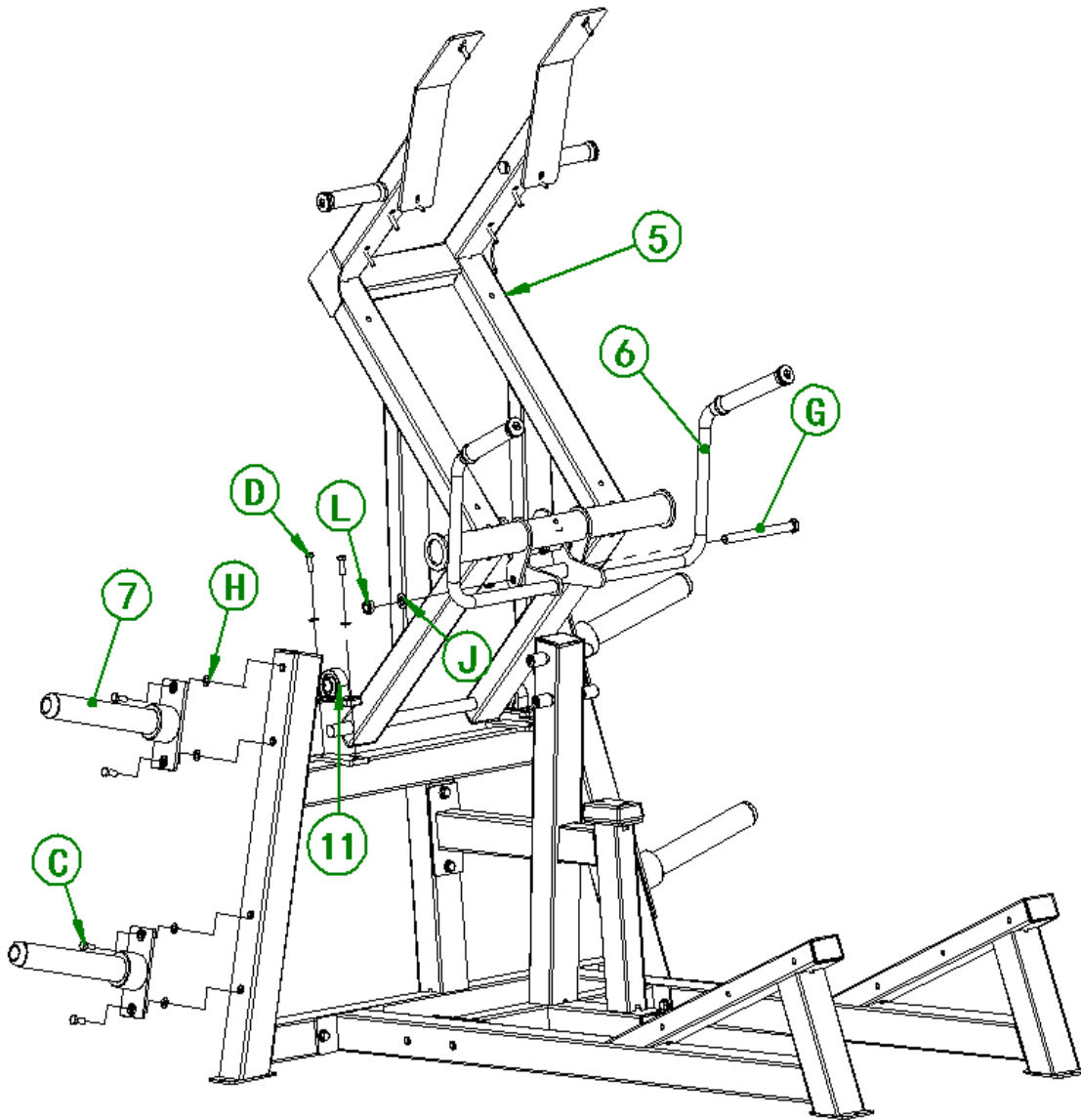

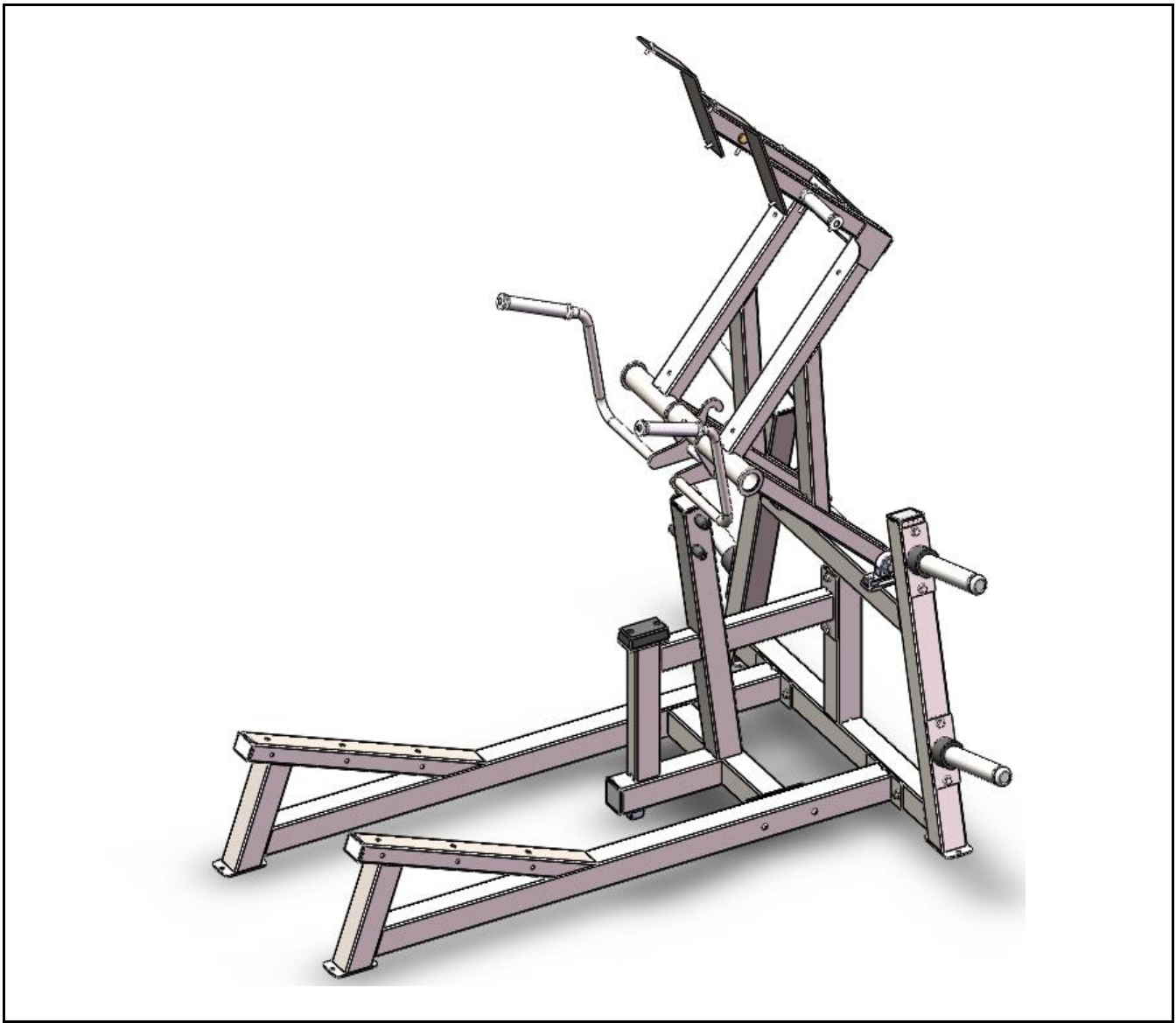

NO.6 Hook welding assembly*1pc

Step NO	Item NO	Name	Quantity	Item NO	Name	Quantity
	NO.27	Powder Metallurgy Bushing	2	NO.26	End front cover	2
	NO.28	Limit bar	1	NO.25	Φ25handle rubber	2
	Q	M8 star nut	2	S	M5*25 flat countersunk head screws	2
	NO.29	Aluminum back cover	2	R	M5*6 top wire	4
	T	M16*140 outer hexagon screw	1	J	Φ16 spacer	1
				L	M16 Locknut	1

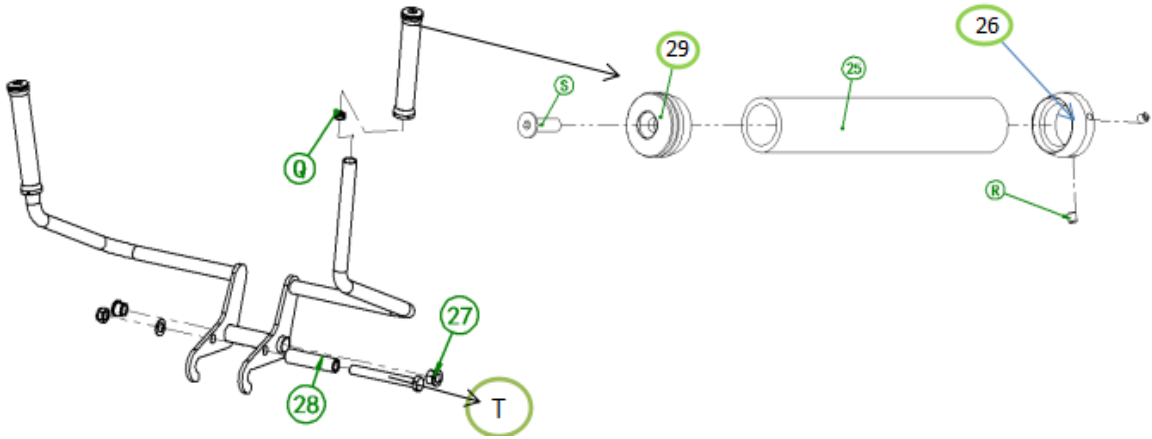

NO.7 Barrel welding assembly*4pcs

Step NO	Item NO	Name	Quantity	Item NO	Name	Quantity
	NO.13	New sheath	1			
	NO.15	Pipe plug	1			

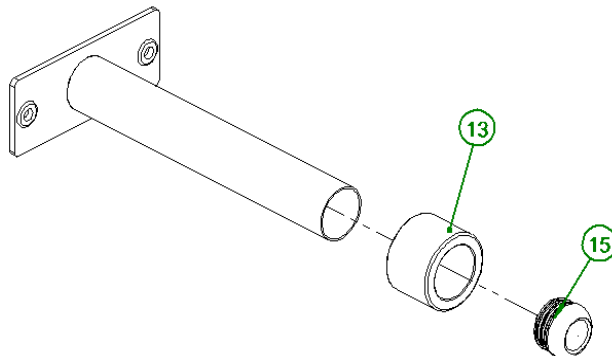

Assembly steps

Step NO	Item NO	Name	Quantity	Item NO	Name	Quantity
3	NO.12	Stainless steel components	1	NO.3	Foot pedal welding assembly	1
	NO.13	New sheath	2	F	M10*75 Hexagon socket screws	1
	NO.14	Lock Jaw Collar	2	E	M10*95 Hexagon socket screws	6
	H	Φ10 spacer	7	K	M10 Locknut	7
				NO.15	Pipe plug	2

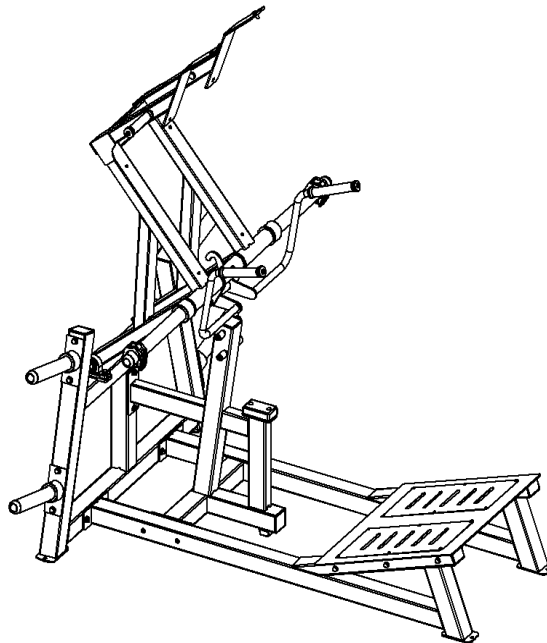
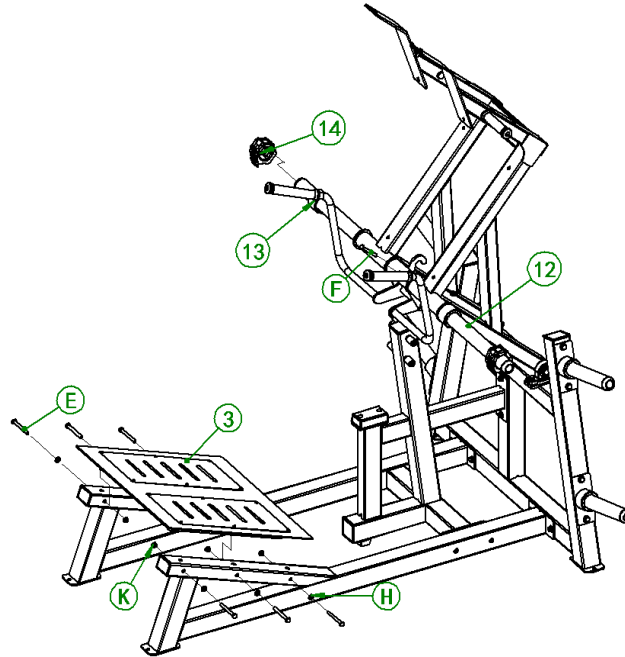

Assembly steps

Step NO	Item NO	Name	Quantity	Item NO	Name	Quantity
4	A	M8*25 outer hexagon screw	4	NO.8	Shoulder pads	2
	B	M8*75 outer hexagon screw	8	NO.9	Bending shoulder pad	2
	I	Φ8 spacer	12	NO.10	Large backrest	1

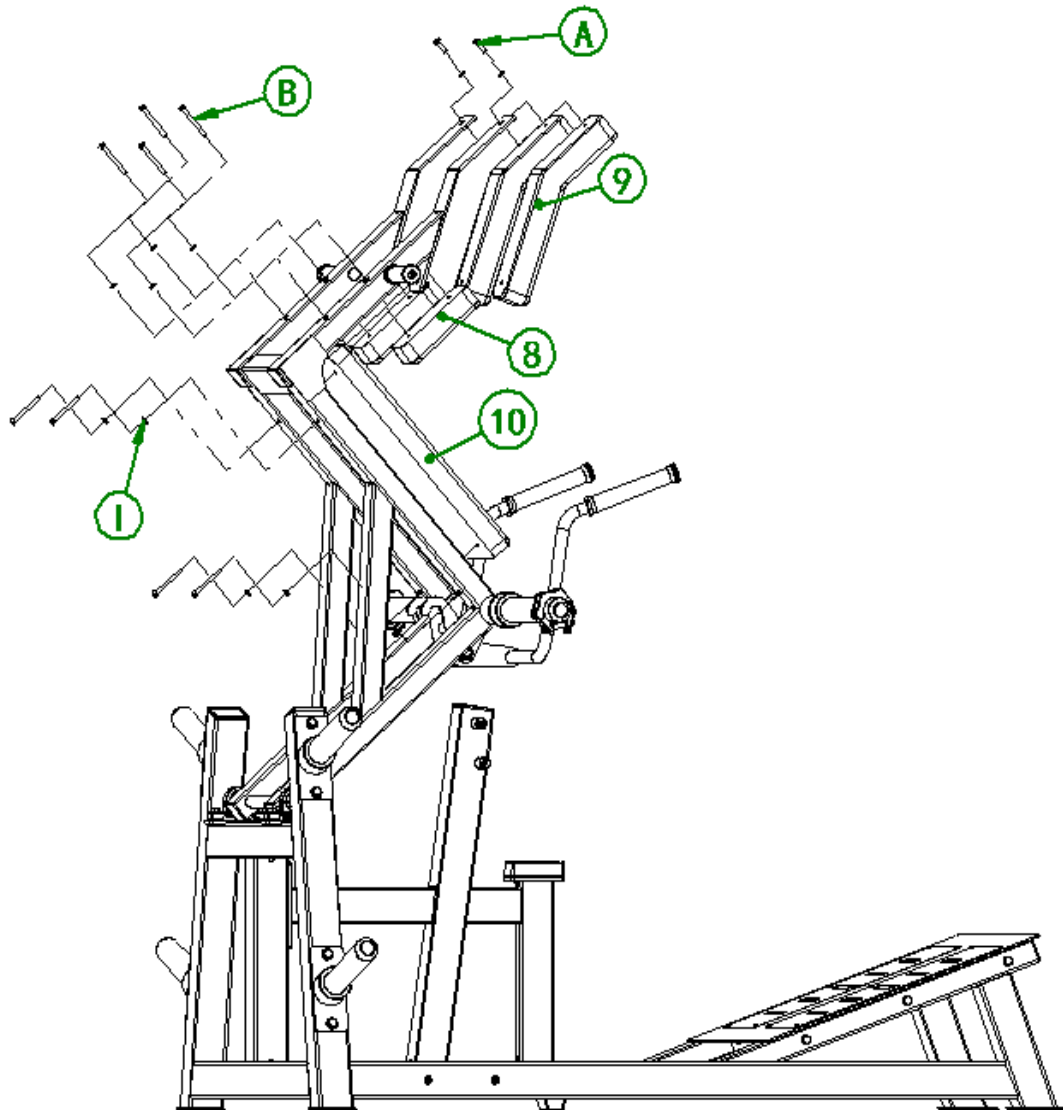

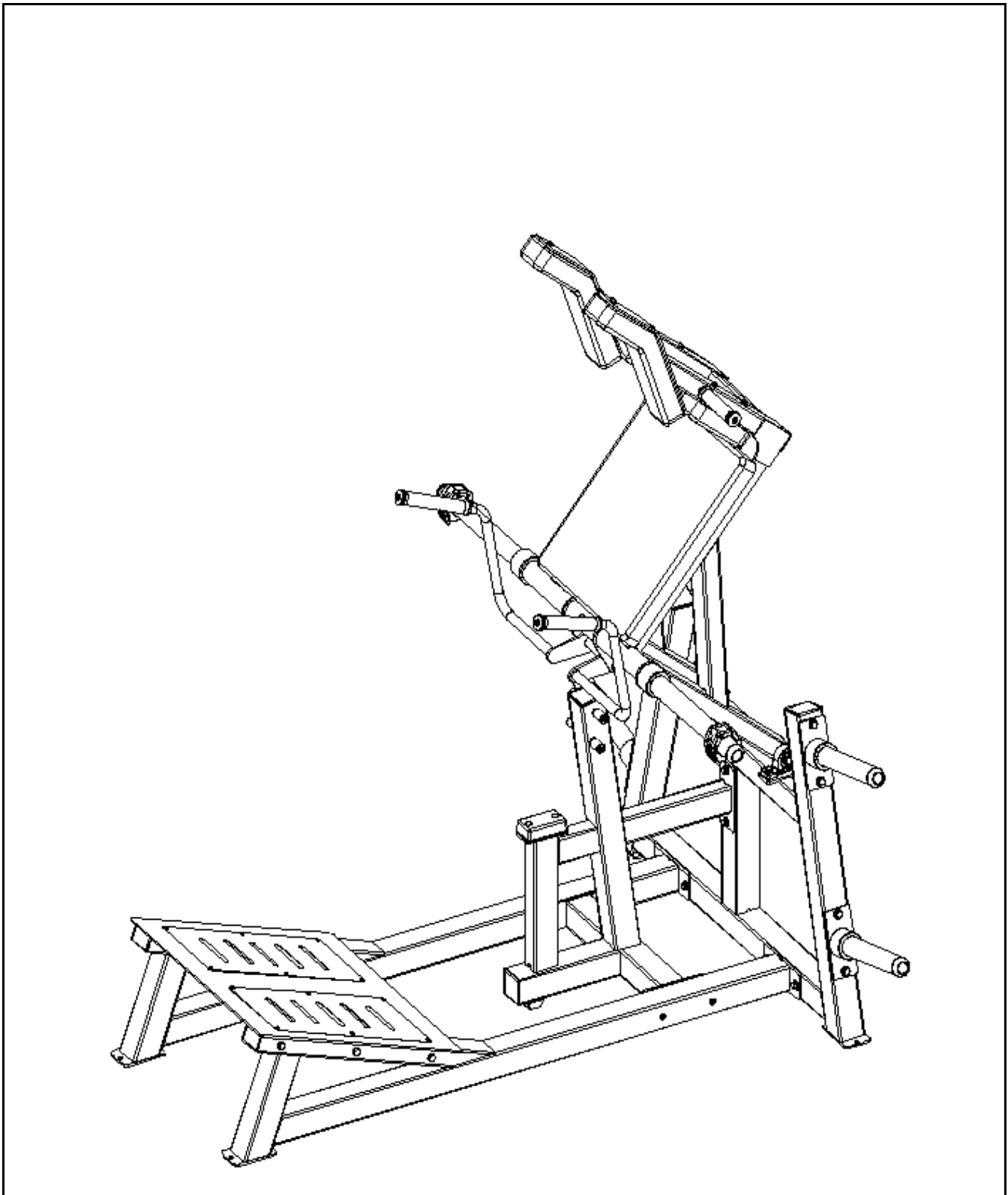

NO.3 Foot pedal welding assembly*1pc

Step NO	Item NO	Name	Quantity	Item NO	Name	Quantity
	X	M5*8 Phillips pan head screw	12			
	30	Aluminum alloy checker plate	2			

