



STRENGTH TRAINING SERIES HALF RACK
No. 54009 WHITE 55009 SILVER

CHECK ITEM QTY DESCRIPTION

ITEM	QTY	DESCRIPTION
1	1	Frame Brace
2	1	Left Upright Frame
3	64	1/2" Flatwashers
4	22	1/2" Locknut
5	1	Left Weight Storage
6	12	1-1/2"ID Rubber Doughnut
7	12	Weight Holders
8	12	1-1/2"ID x 8-1/2" Plastic Tube
9	8	1/2"x4-1/2" Bolts
10	12	1/2"x1" Bolts
11	14	3/8"x3-3/4" Allen Flat Head Bolts
12	10	1/2"x3-3/8" Bolts
13	2	Upright Plastic Board
14	1	Left Base Frame
15	4	4-7/16" x 2-1/4" Foot Pads
16	1	Left Hook Plate
17	8	1/2"x1-1/2" Bolts
18	2	Scratch Guard
19	2	1/4"x5/8" Screw
20	2	1/4" Flat washers
21	1	Stringer
22	1	Crossmember
23	1	Left Single Bar Holder
24	1	Right Upright Frame
25	1	Right Hook Plate
26	1	Right Single Bar Holder
27	1	Pull Up Bar
28	1	Right Weight Storage
29	4	1/2"x3-1/4" Bolts
30	1	Right Base Frame
31	8	Rubber Plug
32	1	York Nameplate
33	1	Warning Label
34	1	Warranty Card
35	1	Serial # Sticker
36	1	Hardware Card
37	1	Assembly Instruction

REV. 08/08/2007

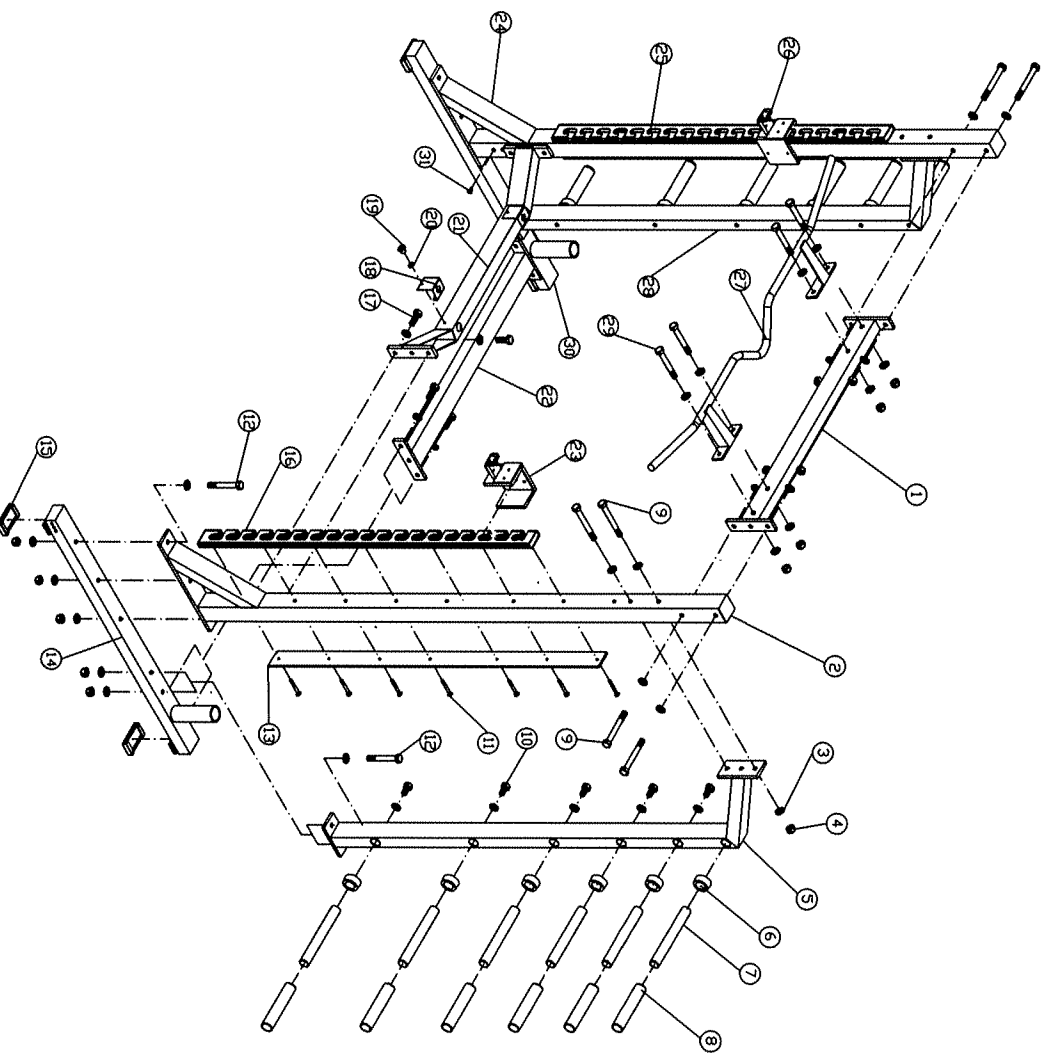

****IF PARTS ARE MISSING, DO NOT CALL THE STORE WHERE YOU PURCHASED THIS ITEM - THEY DO NOT STOCK PARTS. PLEASE CONTACT YORK BARBELL CUSTOMER SERVICE AT (800)358-9675 OR (717)767-6481**