

C-PRO91305-W CALF & SQUAT MACHINE

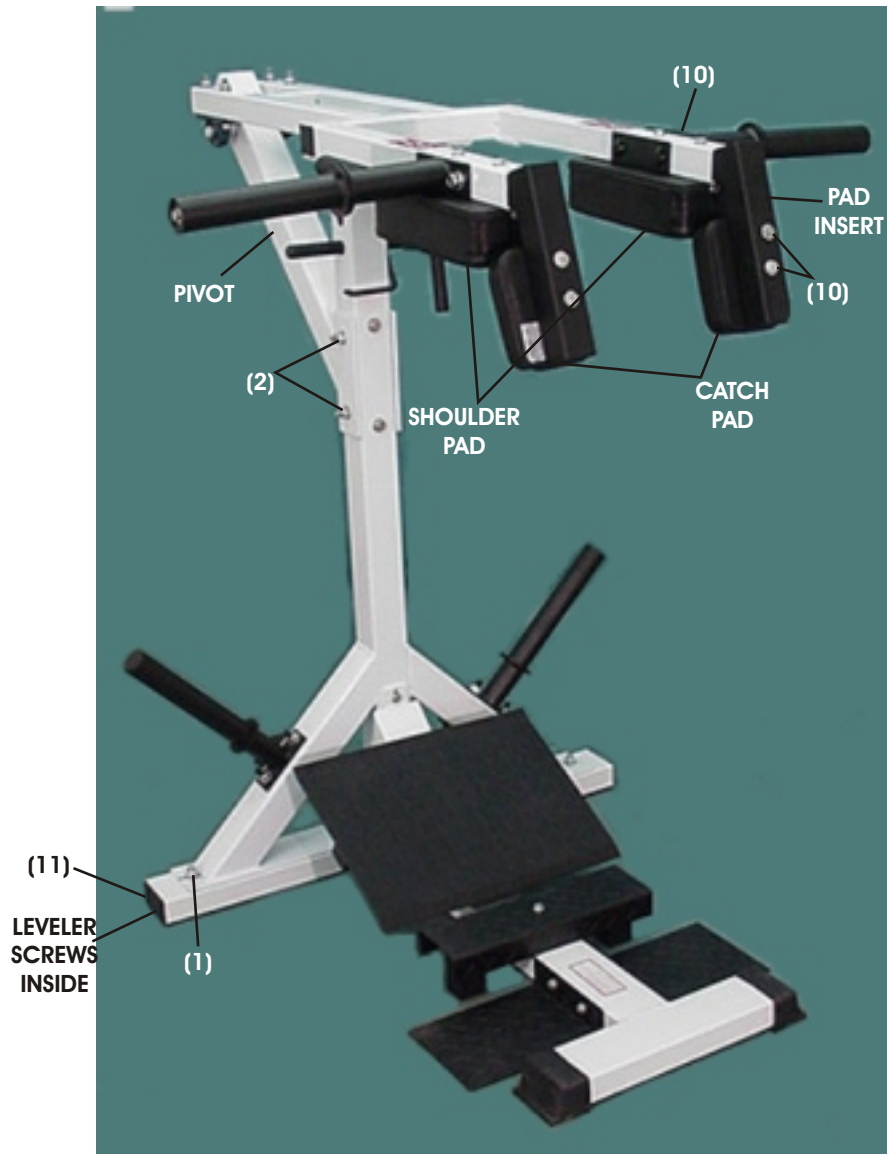

T.D.S. FITNESS EQUIPMENT
P.O. BOX 4189
ELMIRA, NY 14094, USA
607-733-6789

DRAWING # 1

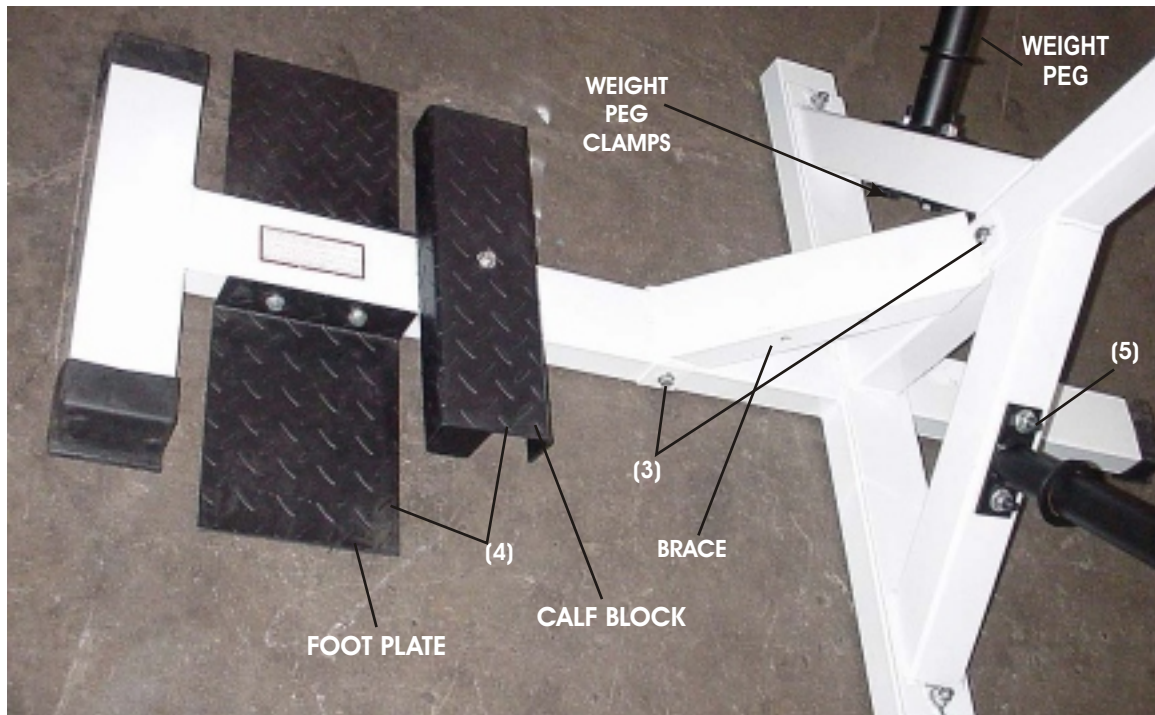
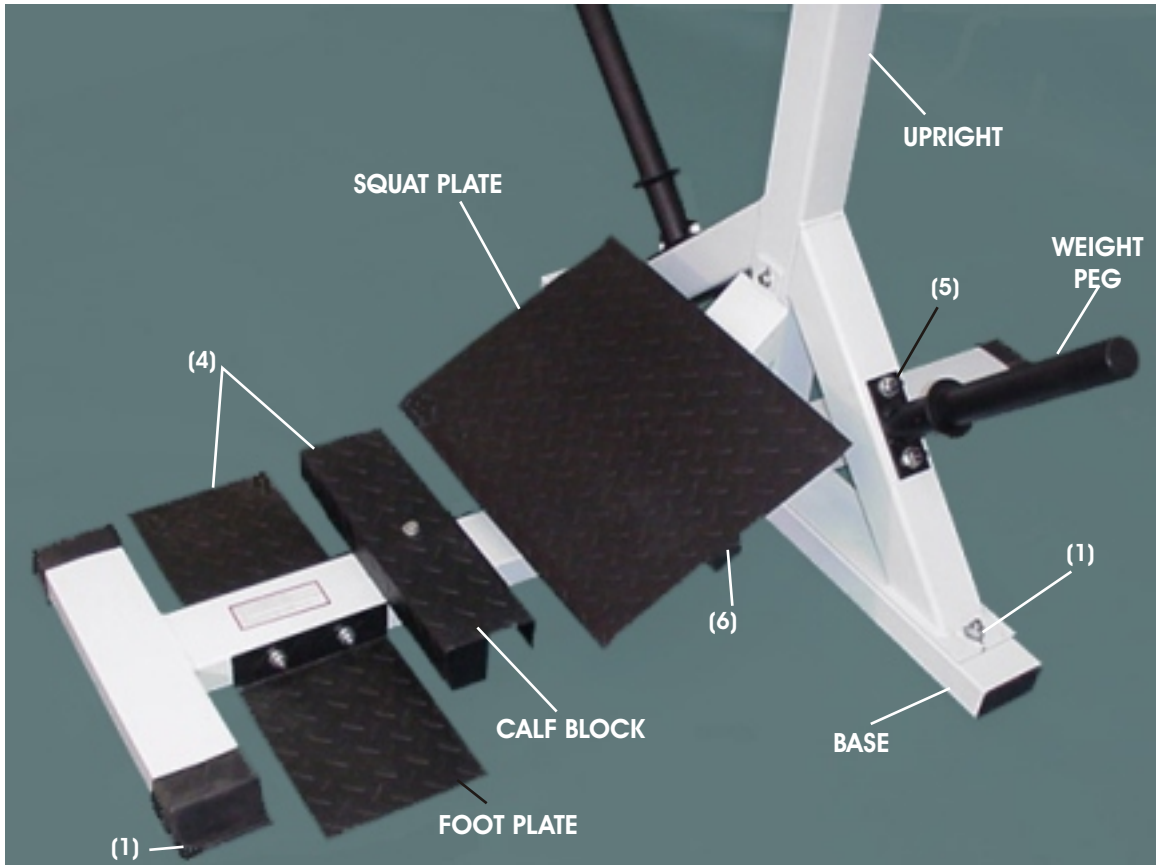

DRAWING # 4

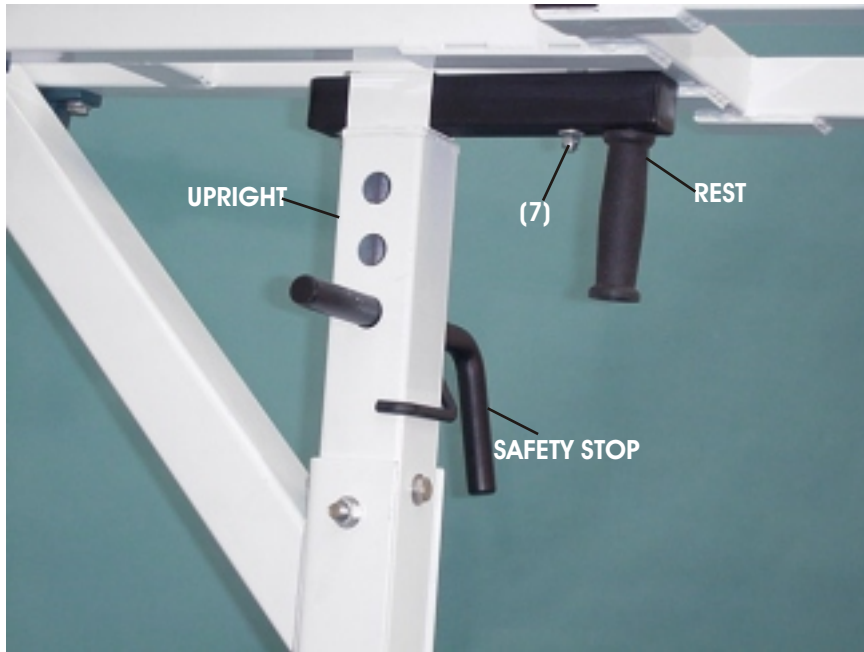

DRAWING # 5

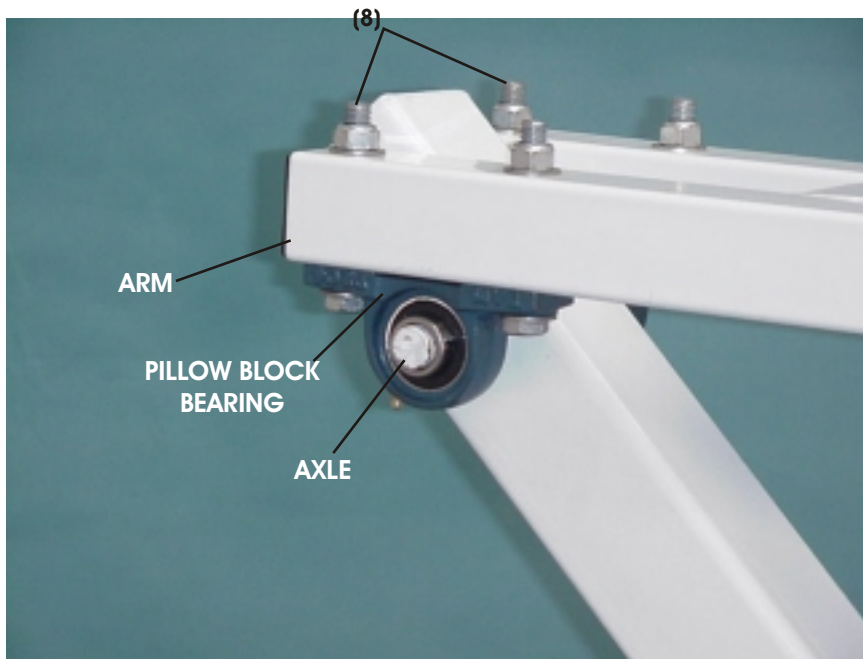

C-PRO91305-W

CALF & SQUAT SYSTEM

PACKING LIST 1 OF 2

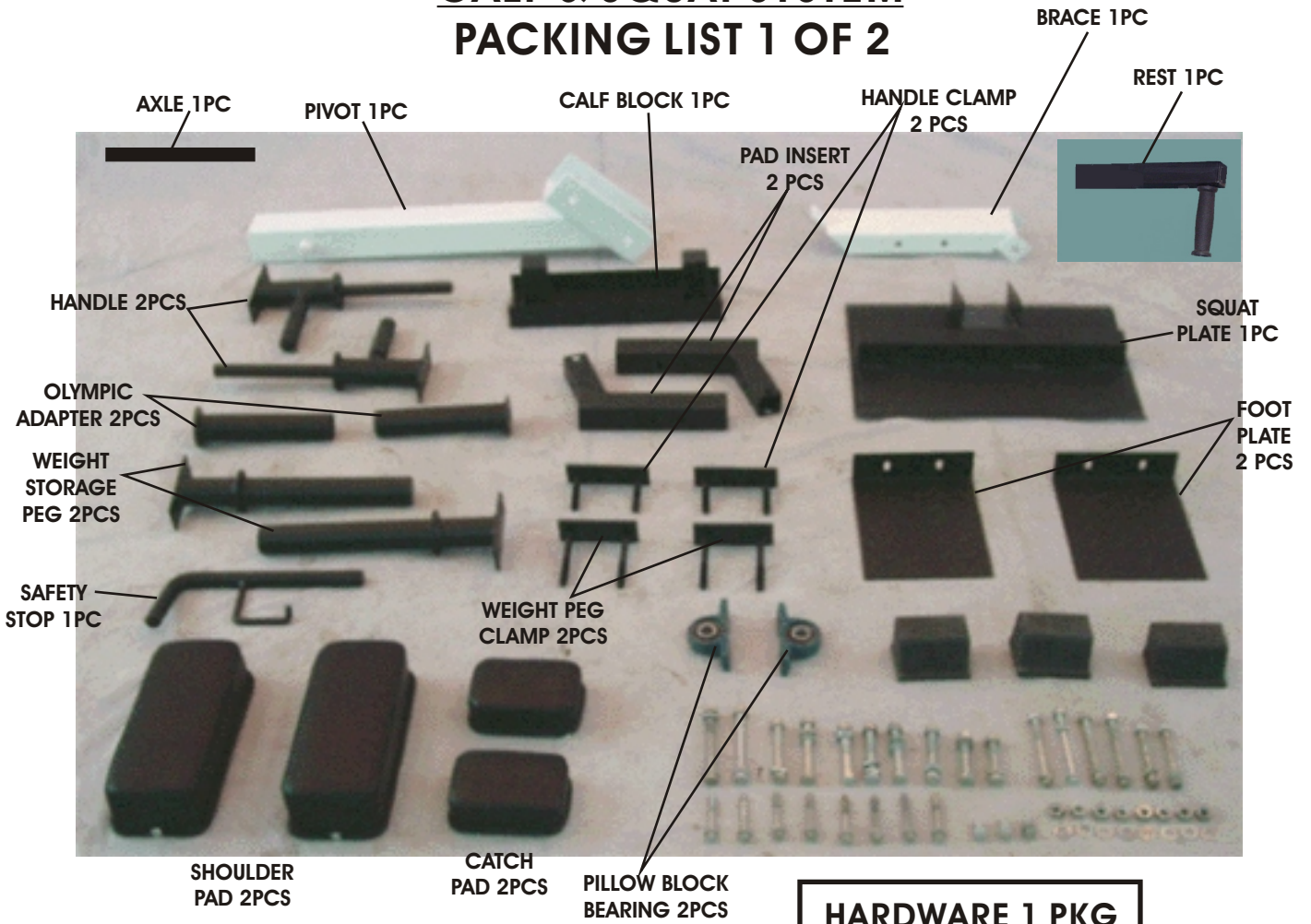

HARDWARE 1 PKG

LITERATURE 1 PKG

C-PRO91305-W
CALF & SQUAT SYSTEM
PACKING LIST 2 OF 2

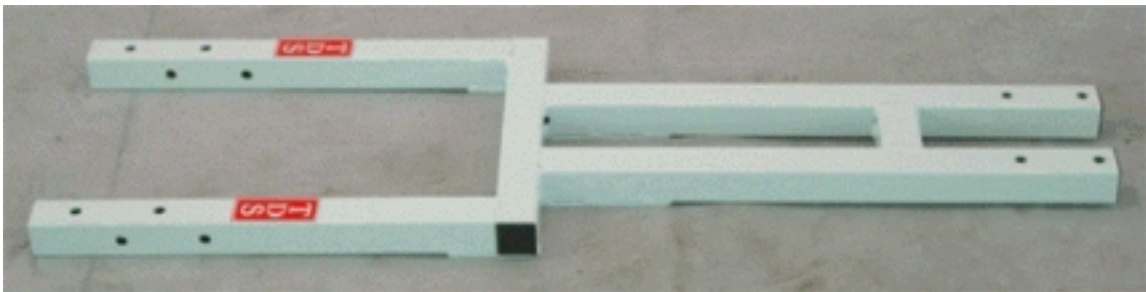
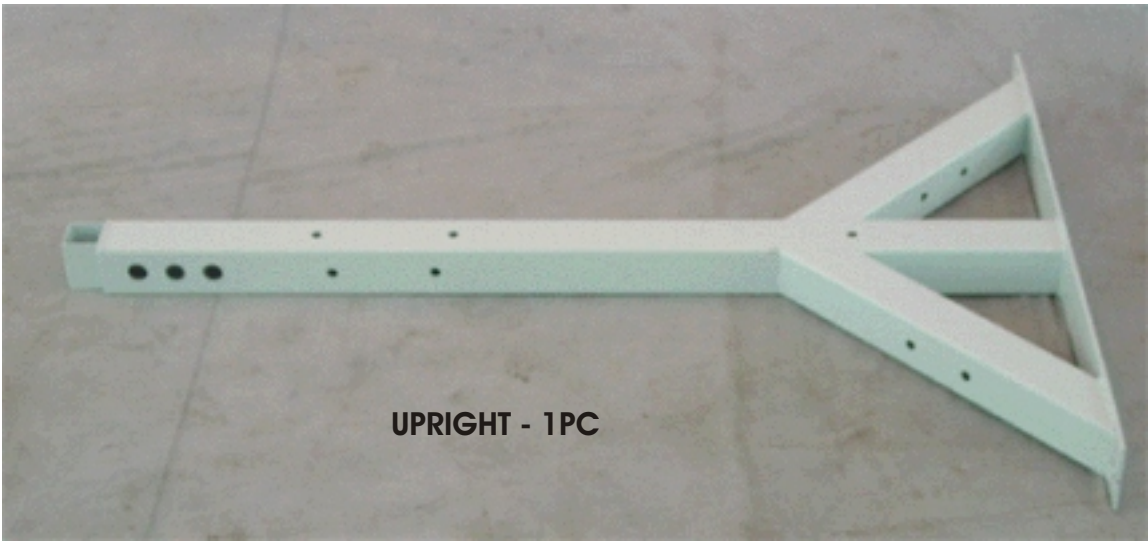
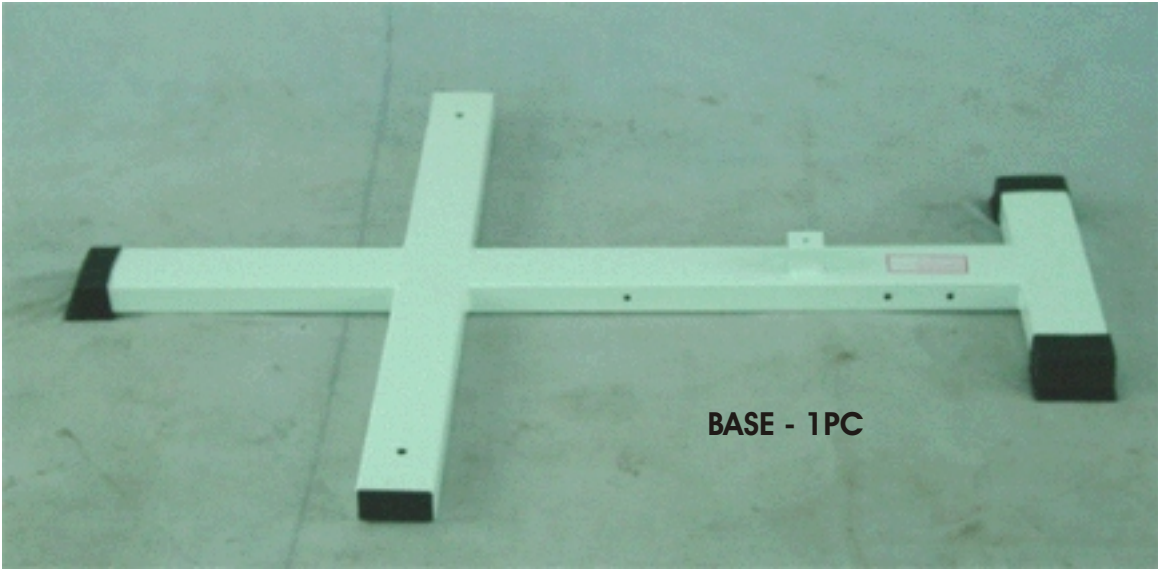

C PRO91305 CALF SQUAT SYSTEM: ASSEMBLY INSTRUCTIONS

THIS UNIT REQUIRES (2) 9/16 WRENCHES, (1) 1 1/16 WRENCH AND (2) 3/4 WRENCHES FOR ASSEMBLY. DO NOT TIGHTEN HARDWARE UNTIL INSTRUCTED TO.

SEE DRAWING #1 AND DRAWING #2

(1) PUSH (3) 2 X 4 FOOT ONTO BASE. ATTACH UPRIGHT TO BASE WITH (2) 1/2 X 3 BOLTS, (4) 1/2 FLAT WASHERS AND (2) 1/2 LOCKNUTS.

(2) ATTACH PIVOT TO UPRIGHT WITH (4) 1/2 X 4 BOLTS, (8) 1/2 FLAT WASHERS AND (4) 1/2 LOCKNUT.

SEE DRAWING #3

(3) ATTACH BRACE TO UPRIGHT WITH (1) 3/8 X 4 BOLT, (1) 3/8 X 5 BOLT, (4) 3/8 FLAT WASHER AND (2) 3/8 LOCKNUT.

SEE DRAWING #1 AND #3

(4) ATTACH (2) FOOT PLATE TO BASE WITH (2) 3/8 X 5 BOLT, (4) 3/8 FLAT WASHER, AND (2) 3/8 LOCKNUT. ATTACH CALF BLOCK TO BASE WITH (1) 3/8 X 1 BOLT AND (1) 3/8 FLAT WASHER.

(5) ATTACH (2) WEIGHT PEGS AND (2) WEIGHT PEG CLAMPS TO UPRIGHT WITH (4) 1/2 FLAT WASHERS AND (4) 1/2 LOCKNUTS. SET UNIT ON LEVEL SURFACE AND TIGHTEN HARDWARE.

(6) ATTACH SQUAT PLATE TO BRACE WITH (2) 3/8 X 5 BOLTS, (4) 3/8 FLAT WASHERS AND (2) 3/8 LOCKNUTS.

SEE DRAWING #4

(7) PUSH REST THRU SOCKET IN UPRIGHT. ATTACH (2) 3/8 X 2 1/2 BOLT, (4) 3/8 FLAT WASHERS AND (2) 3/8 LOCKNUTS ONTO REST. TIGHTEN BOLTS. INSERT SAFETY STOP INTO UPRIGHT.

(8) ATTACH (2) PILLOW BLOCKS TO ARM WITH (4) 1/2 X 3 1/2 BOLTS, (8) 1/2 FLAT WASHER AND (4) 1/2 LOCKNUT. NOTE: PILLOW BLOCKS ARE INSTALLED ON THE BOTTOM SIDE. SET ARM ON REST. INSTALL AXLE THRU PILLOW BLOCKS AND UPRIGHT. THE PILLOW BLOCK RETAINING COLLARS MUST BE TO THE OUTSIDE. TIGHTEN BOLTS. THEN TIGHTEN ALLEN SCREWS ON RETAINING RINGS. CHECK THAT ARM MOVES FREELY.

SEE DRAWING #2

(9) PUSH PAD INSERTS INTO ARM. ATTACH (2) HANDLES TO ARM WITH (2) HANDLE CLAMPS WITH (4) 1/2 WASHERS AND (4) 1/2 LOCKNUTS. TIGHTEN HARDWARE.

(10) ATTACH (2) SHOULDER PAD AND (2) CATCH PAD TO ARM WITH (8) 3/8 X 2 1/2 BOLTS AND (8) 3/8 FLAT WASHERS. CENTER PADS AND TIGHTEN HARDWARE.

(11) LEVEL UNIT WITH LEVELER SCREWS INSIDE BASE.

(12) INSTALL (8) 2 INCH PLUGS, (2) 1 3/4 INCH PLUGS AND (2) 2 X 4 INCH PLUGS.

HARDWARE LIST

(1) 3/8 X 1 BOLT
(10) 3/8 X 2 1/2 BOLTS
(1) 3/8 X 4 BOLTS
(5) 3/8 X 5 BOLTS
(25) 3/8 FLAT WASHERS
(8) 3/8 LOCKNUTS
(2) 1/2 X 3 BOLTS
(4) 1/2 X 3 1/2 BOLTS
(8) 1/2 X 4 BOLTS
(36) 1/2 FLAT WASHERS
(22) 1/2 LOCKNUTS
(8) 2 INCH PLUGS
(2) 1 3/4 INCH PLUGS
(2) 2 X 4 INCH PLUGS
(3) 2 X 4 INCH FOOT