



G8032UB UTILITY BENCH
OWNER' S MANUAL & PARTS LIST

www.tagfitness.net

PARTS LIST

PART NUMBER	DESCRIPTION	QUANTITIES
1	Base Frame	1
2	Main Frame	1
3	Back Pad	1
4	Seat Pad	1
5	Foot Padding	3
6	End Cap 50x100mm	3
7	End Cap 40x80mm	2
8	Rubber Floor Pad	3
9	Allen Bolt M8x60mm (2-3/8")	6
10	Flat Washer M8	6
11	Allen Bolt M12x70mm (2-3/4")	2
12	Flat Washer M12	2
13	Allen Bolt M8x10mm (3/8")	9
14	Screw M5x10mm (3/8")	6
15	Name Plate	2
16	Rivet 4x12mm	4

UTILITY BENCH

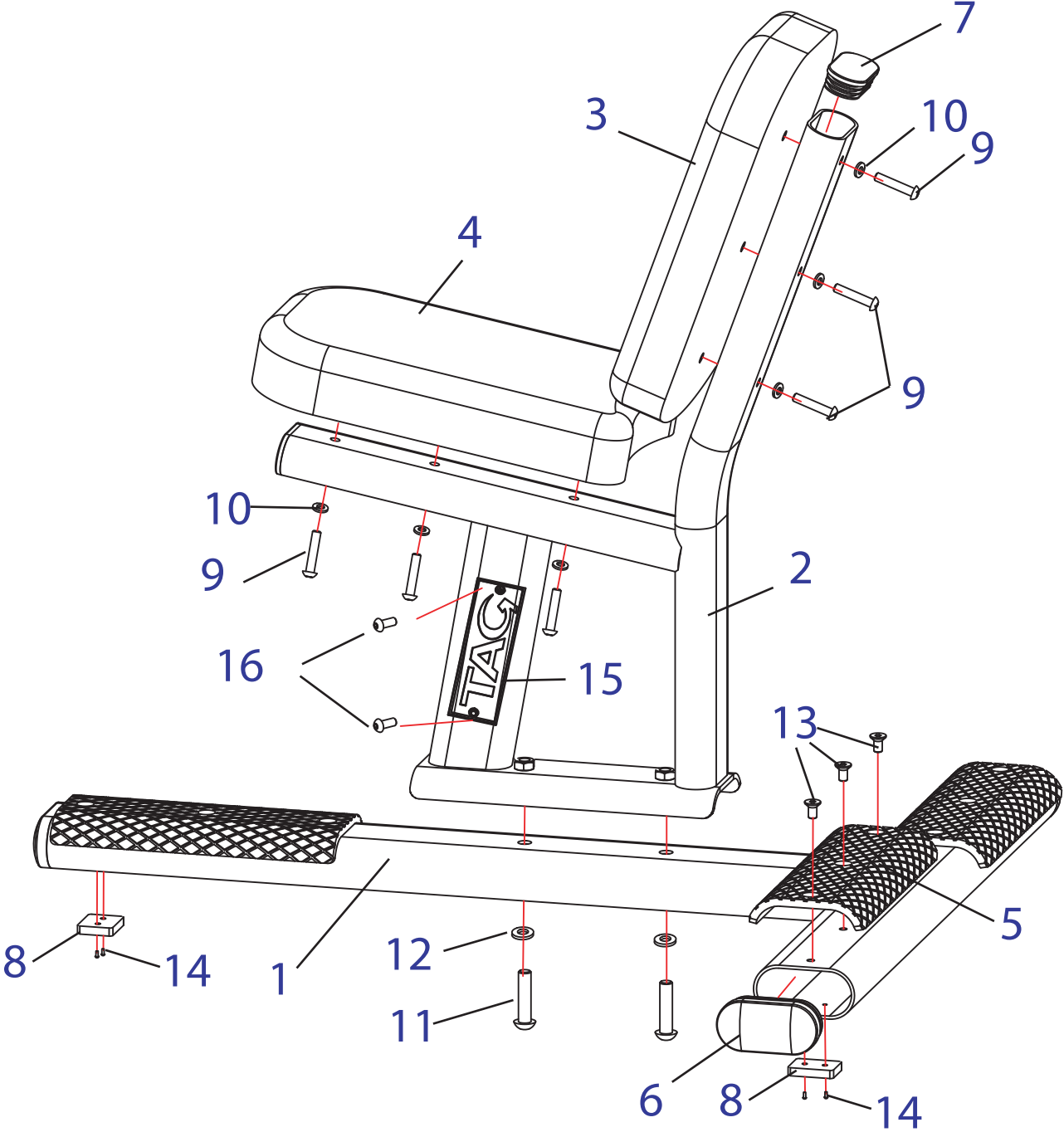

ASSEMBLY

STEP 1

Please connect the Main Frame [2] to the Base Frame [1], using 2 Allen Bolts [11] and 2 Flat Washers [12]. Please tighten the bolts.

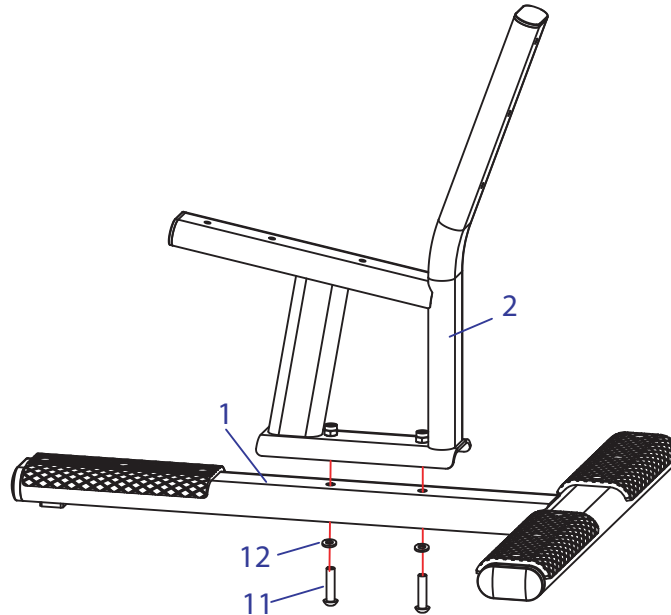

STEP 2

Please attach the Back Pad [3] and Seat Pad [4] to the Main Frame [2], using 6 Allen Bolts [9] and 6 Flat Washers [10]. Please tighten the bolts.

