

FLUIDPOWERERG

SKI ERGOMETER

The FDF FluidPowerERG is a heavy-duty, commercial quality ski ergometer designed to withstand high intensity, powerful workouts for your core, arms and back. It also delivers silky smooth resistance suitable for warm ups and rehabilitation.

The unique constant load of the ERG is delivered via the unique semi isokinetic properties of our 10 levels of Adjustable Fluid Resistance provided by our patented Twin Tank system. The load is instantly available from the very top of the action and consistent to the end, even at explosive HIIT workout speeds.

The ERG facilitates single side double hand diagonal chopping movements for the advanced functional training athlete. With the correct application of resistance, speed and range of motion these complex movements can be tailored to suit beginners.

The ERG allows for bilateral and unilateral arm movements. Switching between the two is seamless, adding greater variety and challenges to any training zone; Cardio, Power, Strength or Speed.

The ERG is a perfect inclusion for any type of fitness facility as a stand-alone machine or in combination with one or all of the FluidPowerZone machines; CLIMB, ROW, UBE, PRESS and CUBE.

BILATERAL ACTION



UNILATERAL ACTION



FLUID POWER ZONE



Swivel pulley for more complex movement patterns

Ergonomic handles for comfortable and secure grip

Bluetooth monitor

Positive instant resistance throughout the entire range - at any speed

Wide foot plates provide stability and foot placement range

Steel frame

Robust rear transport wheels



MINIMUM



10x
FLUID RESISTANCE

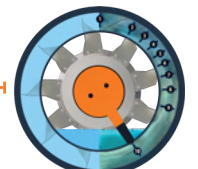

MAXIMUM

COLOUR OPTIONS: ORANGE GREY CUSTOM

VISIT [FLUIDPOWERZONE.COM](https://www.fluidpowerzone.com) FOR MORE WORKOUT OPTIONS

TRAIN IN ANY ZONE. CARDIO. POWER. STRENGTH. SPEED.

FLUIDPOWERERG

PRODUCT SPECIFICATIONS

PRODUCT MODEL NO:	PZ-ERG
FLUID RESISTANCE:	Vertical FDF Twin Tank - 10 levels
MONITOR:	FDF Bluetooth / Heart Rate Compatible
PRODUCT NET WEIGHT:	90.25kg [198.42lb]
PRODUCT GROSS WEIGHT:	108.25kg [238.65lb]
DIMENSIONS:	L 1,450mm [57.1"] x W 810mm [31.9"] x H 2,200mm [86.61"]
MIN ACTIVE AREA REQUIRED:	L 1,950mm [76.8"] x W 1,410mm [55.5"]
MAX USER WEIGHT:	180kg [396.8lb]
VERTICAL SPACE:	H 2,150mm [84.6"]
COMMERCIAL WARRANTY:	Frame 10 years - Fluid Tank 5 years Mechanical and all other non wearing components - 2 years



FLUID POWER ZONE



CONSOLE FEATURES

- + Bluetooth Connectivity
- + AUTO START
- + TIME - Elapsed time
- + LEVEL - Selected resistance level
- + WATT - Unit of power
- + WORK - Interval Duration
- + REST - Rest Interval
- + DIST - Distance (Rowers only)
- + REPS - Total Repetitions
- + RPM/SPM - Revolutions/Strokes per min
- + PULSE - Heart rate - Polar compatible
- + CAL - Calories burned per hour/total cal
- + Power Graphs - 2 Options

ERGONOMIC HANDLES & SWIVEL PULLEYS

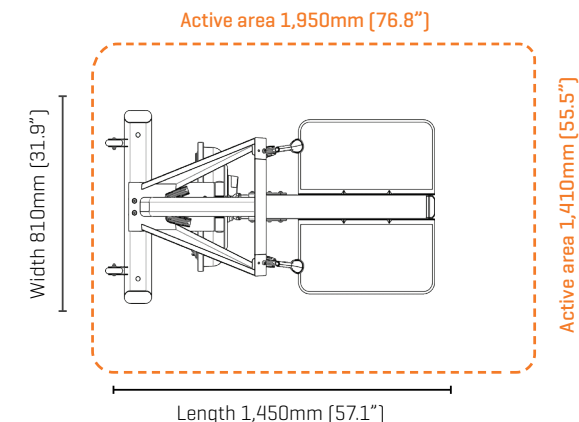

ABOUT FLUIDPOWERZONE MACHINES

FluidPowerZone is a range of Fluid Resistance fitness machines, designed for training in any Zone- Cardio, Power, Strength or Speed. FluidPowerZone machines can be used individually, or by combining multiple machines to make up a fitness circuit. The patented Twin Tank technology delivers 10 different levels of adjustable Fluid Resistance for concentric only movements that will accommodate all levels and abilities, from general fitness enthusiasts to elite athletes and provides a perfect platform for rehabilitation/medical applications.

ABOUT FDF (FIRST DEGREE FITNESS)

FDF is the leader in designing and manufacturing a range of adjustable Fluid Resistance fitness machines for commercial and residential applications. At the heart of the fitness range is our unique and patented Twin Tank Fluid Resistance system. The adjustable Fluid Resistance system challenged the conventional thinking of how water could work to provide adjustable resistance rather than just a liquid mass flywheel. The patented Twin Tank system provides silky smooth resistance at any speed and is perfect for cardio training, warm-ups, cool downs, intense HIIT workouts or rehabilitation programs. FDF categorizes the range of adjustable Fluid Resistance machines under the banners, **FluidRower**, **FluidExercise** and **FluidPowerZone**, see the adjacent web links. FDF products are distributed throughout the globe and are popular in Fitness Centers, Hotels and Apartments, Sporting Clubs, Universities, First Responders, Defence Force Training Facilities and Physical Rehabilitation Clinics.



View all product ranges at

[FLUIDPOWERZONE.com](https://www.fluidpowerzone.com)

[FLUIDROWER.com](https://www.fluidrower.com)

[FLUIDEXERCISE.com](https://www.fluidexercise.com)

* FDF reserves the right to modify any product design, manufacture or aesthetic without notice or consultation. Product specifications and warranties may vary from country to country.



ROW



PRESS



CLIMB



UBE



CUBE