

# FLUIDPOWERROW

## ROWING MACHINE

The FDF FluidPowerROW is a high-quality commercial grade rowing ergometer with an instant natural catch and a smooth consistent feel through the whole stroke. The resistance is provided by the unique semi isokinetic properties of our 10 levels of Adjustable Fluid Resistance provided by our patented Twin Tank system.

The ROW will cater for the explosive power of any HIIT workout all day every day, and yet remains silky smooth at any combination of stroke rate and resistance making it suitable for long cardio sessions, warm ups, cool downs and rehabilitation.

Rowing has long been viewed as an efficient training modality for your whole body; the FluidPowerROW takes this efficiency to new levels. Set the Fluid Resistance, choose your stroke rate and range of motion to train effectively in any zone; Cardio, Power, Strength or Speed.

The ROW has a unique robust design with the adjustable Fluid Resistance Twin Tank side mounted, a convenient height rowing seat and a comparatively short frame length. The attractive design provides practical benefits for easy access and minimal floor space requirements.

Every fitness facility needs at least one rowing machine and the unique versatility of FluidPowerROW makes it the obvious choice. Partner the ROW with other FluidPowerZone machines to create motivating individual or group training options.

CATCH



FINISH



# FLUID POWER ZONE



MINIMUM



MAXIMUM



COLOUR OPTIONS:  ORANGE  GREY  CUSTOM

VISIT [FLUIDPOWERZONE.COM](https://www.fluidpowerzone.com) FOR MORE WORKOUT OPTIONS

**TRAIN IN ANY ZONE. CARDIO. POWER. STRENGTH. SPEED.**

# FLUIDPOWERROW

## PRODUCT SPECIFICATIONS

|                           |  |
|---------------------------|--|
| PRODUCT MODEL NO:         | PZ-R0W   |
| FLUID RESISTANCE:         | FDF Vertical Twin Tank - 10 Levels   |
| MONITOR:                  | FDF Bluetooth / Heart Rate Compatible  |
| PRODUCT NET WEIGHT:       | 61.9kg [136.5lb]   |
| PRODUCT GROSS WEIGHT:     | 71.5kg [157.63lb]  |
| DIMENSIONS:               | L 1,950mm [76.77"] x W 810mm [31.89"] x H 860mm [33.9"]  |
| MIN ACTIVE AREA REQUIRED: | L 2,550mm [100.4"] x W 1,310mm [51.6"]   |
| MAX USER WEIGHT:          | 150kg [330lb]  |
| COMMERCIAL WARRANTY:      | Frame 10 years - Fluid Tank 5 years<br>Mechanical and all other non wearing components - 2 years |

# FLUID POWER ZONE



## CONSOLE FEATURES



- + Bluetooth Connectivity
- + AUTO START
- + TIME - Elapsed time
- + LEVEL - Selected resistance level
- + WATT - Unit of power
- + WORK - Interval Duration
- + REST - Rest Interval
- + DIST - Distance [Rowers only]
- + REPS - Total Repetitions
- + RPM/SPM - Revolutions/Strokes per min
- + PULSE - Heart rate - Polar compatible
- + CAL - Calories burned per hour/total cals
- + Power Graphs - 2 Options

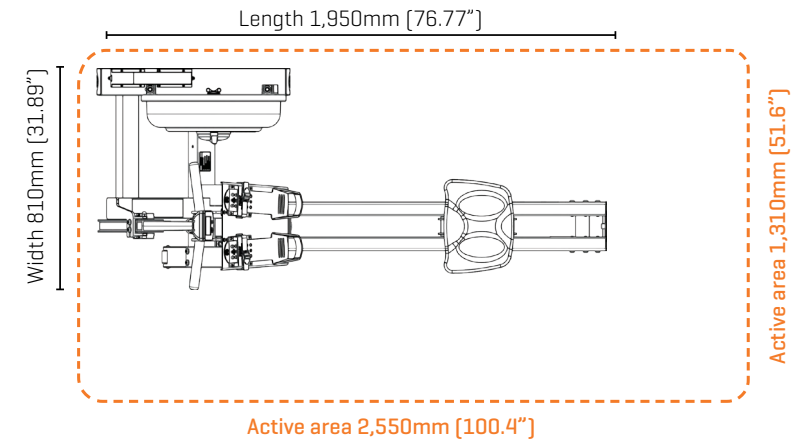

## ABOUT FLUIDPOWERZONE MACHINES

FluidPowerZone is a range of Fluid Resistance fitness machines, designed for training in any Zone- Cardio, Power, Strength or Speed. FluidPowerZone machines can be used individually, or by combining multiple machines to make up a fitness circuit. The patented Twin Tank technology delivers 10 different levels of adjustable Fluid Resistance for concentric only movements that will accommodate all levels and abilities, from general fitness enthusiasts to elite athletes and provides a perfect platform for rehabilitation/medical applications.

## ABOUT FDF (FIRST DEGREE FITNESS)

FDF is the leader in designing and manufacturing a range of adjustable Fluid Resistance fitness machines for commercial and residential applications. At the heart of the fitness range is our unique and patented Twin Tank Fluid Resistance system. The adjustable Fluid Resistance system challenged the conventional thinking of how water could work to provide adjustable resistance rather than just a liquid mass flywheel. The patented Twin Tank system provides silky smooth resistance at any speed and is perfect for cardio training, warm-ups, cool downs, intense HIIT workouts or rehabilitation programs. FDF categorizes the range of adjustable Fluid Resistance machines under the banners, FluidRower, FluidExercise and FluidPowerZone, see the adjacent web links. FDF products are distributed throughout the globe and are popular in Fitness Centers, Hotels and Apartments, Sporting Clubs, Universities, First Responders, Defence Force Training Facilities and Physical Rehabilitation Clinics.



View all product ranges at

[FLUIDPOWERZONE.com](https://www.fluidpowerzone.com)

[FLUIDROWER.com](https://www.fluidrower.com)

[FLUIDEXERCISE.com](https://www.fluidexercise.com)

\* FDF reserves the right to modify any product design, manufacture or aesthetic without notice or consultation. Product specifications and warranties may vary from country to country.



UBE



PRESS



CLIMB



ERG



CUBE