

FLUIDPOWERPRESS

SQUAT TO OVERHEAD PRESS MACHINE

The FDF FluidPowerPRESS is an industrial quality, concentric action Squat to Overhead press machine. The resistance is provided by the unique semi isokinetic properties of our 10 levels of Adjustable Fluid Resistance provided by our patented Twin Tank system.

The PRESS enables you to explode with high loads at high speeds, without having to deal with the eccentric loading unavoidable with most traditional forms of resistance exercise. This built in safety feature allows both the athlete competing for peak power and the deconditioned first time participant to achieve their fitness and strength goals without intimidation or injury.

The tapered shoulder pads, ergonomic hand rails and counter balanced press arm mean all exercisers can find a comfortable, secure training position without the need to make time consuming adjustments.

The FluidPowerPRESS is a perfect inclusion for any type of fitness facility as a stand-alone machine or in combination with one or all of the FluidPowerZone machines; ROW, UBE, ERG, CLIMB and CUBE.



**FLUID
POWER
ZONE**

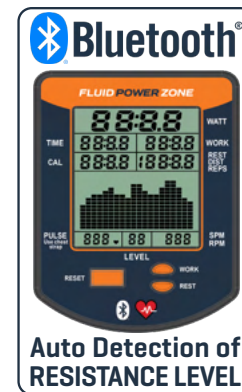

MINIMUM



MAXIMUM

Counter balance minimises press arm weight

Bluetooth monitor

Tapered shoulder pads for secure comfort

Long hand rails for multi-grip positions

Wide foot plates provide stability and foot placement range

Robust rear transport wheels

Steel frame

COLOUR OPTIONS: ORANGE GREY CUSTOM

VISIT [FLUIDPOWERZONE.COM](https://www.fluidpowerzone.com) FOR MORE WORKOUT OPTIONS

TRAIN IN ANY ZONE. CARDIO. POWER. STRENGTH. SPEED.

FLUIDPOWERPRESS

PRODUCT SPECIFICATIONS

PRODUCT MODEL NO:	PZ-PRE
FLUID RESISTANCE:	Vertical FDF Twin Tank - 10 levels
MONITOR:	FDF Bluetooth / Heart Rate Compatible
PRODUCT NET WEIGHT:	104.2kg [229.72lb]
PRODUCT GROSS WEIGHT:	124.70kg [274.91lb]
DIMENSIONS:	L 1,710mm [57.1"] x W 830mm [32.7"] x H 2,450mm [96.5"]
MIN ACTIVE AREA REQUIRED:	L 2,150mm [84.6"] x W 1,600mm [63"]
MAX USER WEIGHT:	180kg [396.8lb]
VERTICAL SPACE:	H 2,480mm [97.6"] at full extension
PRESS ARM WEIGHT:	6kg / 13.2lb
COMMERCIAL WARRANTY:	Frame 10 years - Fluid Tank 5 years Mechanical and all other non wearing components - 2 years

FLUID POWER ZONE



CONSOLE FEATURES

- + Bluetooth Connectivity
- + AUTO START
- + TIME - Elapsed time
- + LEVEL - Selected resistance level
- + WATT - Unit of power
- + WORK - Interval Duration
- + REST - Rest Interval
- + DIST - Distance [Rowers only]
- + REPS - Total Repetitions
- + RPM/SPM - Revolutions/Strokes per min
- + PULSE - Heart rate - Polar compatible
- + CAL - Calories burned per hour/total cals
- + Power Graphs - 2 Options



TAPERED SHOULDER PADS & LONG HAND RAILS

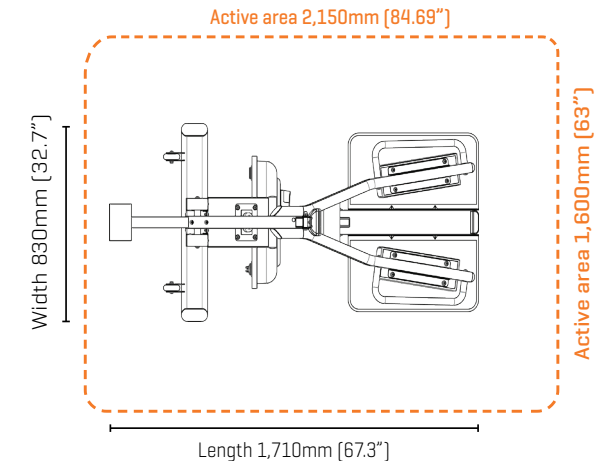

ABOUT FLUIDPOWERZONE MACHINES

FluidPowerZone is a range of Fluid Resistance fitness machines, designed for training in any Zone - Cardio, Power, Strength or Speed. FluidPowerZone machines can be used individually, or by combining multiple machines to make up a fitness circuit. The patented Twin Tank technology delivers 10 different levels of adjustable Fluid Resistance for concentric only movements that will accommodate all levels and abilities, from general fitness enthusiasts to elite athletes and provides a perfect platform for rehabilitation/medical applications.

ABOUT FDF (FIRST DEGREE FITNESS)

FDF is the leader in designing and manufacturing a range of adjustable Fluid Resistance fitness machines for commercial and residential applications. At the heart of the fitness range is our unique and patented Twin Tank Fluid Resistance system. The adjustable Fluid Resistance system challenged the conventional thinking of how water could work to provide adjustable resistance rather than just a liquid mass flywheel. The patented Twin Tank system provides silky smooth resistance at any speed and is perfect for cardio training, warm-ups, cool downs, intense HIIT workouts or rehabilitation programs. FDF categorizes the range of adjustable Fluid Resistance machines under the banners, FluidRower, FluidExercise and FluidPowerZone, see the adjacent web links. FDF products are distributed throughout the globe and are popular in Fitness Centers, Hotels and Apartments, Sporting Clubs, Universities, First Responders, Defence Force Training Facilities and Physical Rehabilitation Clinics.



View all product ranges at

[FLUIDPOWERZONE.com](https://www.fluidpowerzone.com)

[FLUIDROWER.com](https://www.fluidrower.com)

[FLUIDEXERCISE.com](https://www.fluidexercise.com)

* FDF reserves the right to modify any product design, manufacture or aesthetic without notice or consultation. Product specifications and warranties may vary from country to country.



ROW



CLIMB



ERG



UBE



CUBE