

POWERLINE®

by *Body-Solid*

PCC090X
CABLE CROSSOVER

OWNER'S MANUAL

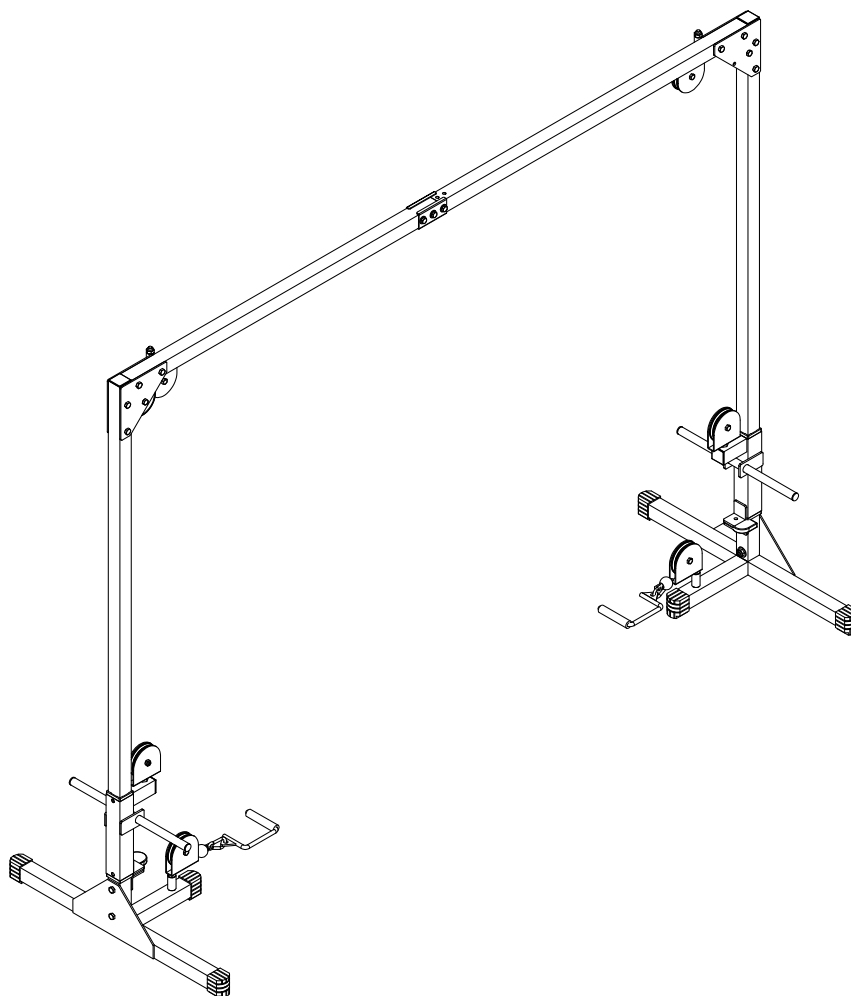

WWW.BODYSOLID.COM

V PCC090X-071218

THERE IS A RISK ASSUMED BY INDIVIDUALS WHO USE THIS TYPE OF EQUIPMENT. TO MINIMIZE RISK, YOU MUST FOLLOW THESE RULES:

1. Inspect equipment before each workout. Check that all nuts, bolts, screws and pop pins are in place and fully tightened. Also, before use, check cables for signs of wear. Replace all worn parts immediately. **Never use machine if any parts are damaged or missing.**
FAILURE TO FOLLOW THESE RULES MAY RESULT IN SERIOUS INJURY.
2. Keep clear of the cables and all moving parts when the machine is in use.
3. Always make sure all Snap Links are closed when doing any cable/pulley/strap exercises.
4. Exercise with care. Perform your exercises at a smooth moderate pace; never perform jerky or uncoordinated movements that may cause injury.
5. It is recommended that you should workout with a training partner.
6. Do not allow children or minors to play on or around this equipment.
7. If unsure of proper use of equipment, call your local Body-Solid distributor or the Body-Solid customer service department at 1-800-556-3113.
8. **WARNING:** Consult your physician before starting your exercise program. For your own safety, do not begin any exercise program without proper instruction. RAL8-6-03 WC-54

WARNING

Safety and Maintenance of Cables

IMPORTANT: Cables are wear items. It is your responsibility to prevent unexpected breakage. **Cable inspection should be performed daily.** Inspect all cables, the nylon coating on all cables, and the area near the fitting at each end of each cable. **Replace any damaged or worn cable immediately.** Do not allow the machine to be used until damaged or worn cables are replaced. Using or allowing a machine to be used with a suspect cable can result in serious injury. See Owner's Manual for more information.

For Body-Solid Customer Service
Call 1-800-556-3113

MAINTENANCE SCHEDULE

Check the function and integrity of the following components. As noted, inspect equipment before each workout. Replace all damaged, broken or worn components immediately.

	D A I L Y	W E E K L Y
Cables: Check tension, end fittings, and coating	✓	
Check that locking nut at weight stack is tight		✓
Upholstery: Wipe down and dry	✓	
Clean and condition		✓
Frame: Wipe down and dry	✓	
Polish / Wax		✓
Chrome: Wipe down and dry	✓	
Polish / Lubricate		✓
Nuts / Bolts / Fasteners: Tighten and / or adjust as needed		✓
Guide Rods: Lubricate and clean		✓
Linear Rods: Lubricate and clean		✓
Seat Sleeves: Lubricate and clean		✓
Adjustments / Locking Pins / Tightening Knobs		✓
Weight Stack Pins		✓
Warning Instruction Labels		✓
Springs / Pop Pins	✓	
Anti Skid Surfaces		✓
Hand Grips / Rollers		✓

For Body-Solid Customer Service
Call 1-800-556-3113
#MSSTKR0803

PCC090X

TABLE OF CONTENTS

- **SAFETY INSTRUCTIONS..... PAGE 4**
- **PREPARATION..... PAGE 5**
- **PART/HARDWARE LIST..... PAGE 6**
- **HARDWARE ILLUSTRATION..... PAGE 7**
- **ASSEMBLY INSTRUCTIONS..... PAGE 10**
- **EXPLODED VIEW..... PAGE 23**
- **CONTACT PAGE..... PAGE 24**

PCCO90X

SAFETY INSTRUCTIONS

**WHEN USING EXERCISE EQUIPMENT,
YOU SHOULD ALWAYS TAKE BASIC
PRECAUTIONS INCLUDING THE
FOLLOWING:**

- Read all instructions before using the PCCO90X. These instructions are written to ensure your safety and to protect the unit.
- **Do not remove any safety labels from the machine.**
- Do not allow children on or near the equipment.
- Use the equipment only for its intended purpose as described in this guide. Do not use accessory attachments that are not recommended by the manufacturer. Such attachments might cause serious injuries.
- Wear proper exercise clothing and shoes for your workout, no loose clothing.
- Keep hands, limbs, loose clothing, and long hair well out of the way of all moving parts
- Use care when getting on or off the unit.
- Do no overexert yourself or work to exhaustion.
- If you feel any pain or abnormal symptoms, stop your workout immediately and consult your physician.
- Never operate unit when it has been dropped or damaged. Return the equipment to a service center for examination and repair.
- Never drop or insert objects into any opening in the equipment.
- Always check the unit and its cables before each use. Make sure that all fasteners and cables are secure and in good working condition.
- Do not use the equipment outdoors or near water.

PERSONAL SAFETY DURING ASSEMBLY

- Before beginning assembly, please take the time to read the instructions thoroughly.
- Read each step in the assembly instructions and follow the steps in sequence. Do not skip ahead. If you skip ahead, you may learn later that you have to disassemble components and that you may have damaged the equipment
- Assemble and operate the PCCO90X on a solid, level surface. Locate the unit a few feet from the walls or furniture to provide easy access.

The PCCO90X is designed for your enjoyment. By following these precautions and using common sense, you will have many safe and pleasurable hours of healthful exercise with your Powerline Cablecrossover. After assembly, you should check all functions to ensure correct operation. If you experience problems, first recheck the assembly instructions to locate any possible errors made during assembly. If you are unable to correct the problem, call the dealer from whom you purchased the machine or call 1-800-556-3113 for the dealer nearest you.

OBTAINING SERVICE

Please use this Owner's Manual to make sure that all parts have been included in your shipment. When ordering parts, you must use the part number and description from this Owner's Manual. Use only Powerline by Body Solid replacement parts when servicing this machine. Failure to do so will void your warranty and could result in personal injury.

For information about product operation or service, check out the official Powerline website at www.bodysolid.com or contact an authorized Powerline dealer or a Powerline factory-authorized service company or contact Body-Solid customer service at one of the following:

Toll Free: 1-800-556-3113
Phone: 1-708-427-3555
Fax: 1-708-427-3556
Email: service@bodysolid.com

Or write to: Body-Solid, Inc.
Service Department
1900 S. Des Plaines Ave.
Forest Park, IL 60130 USA

**RETAIN THIS OWNER'S MANUAL FOR
FUTURE REFERENCE. PART NUMBERS
ARE REQUIRED WHEN ORDERING PARTS.**

PCCO90X

PREPARATION

REQUIRED TOOLS

The basic tools that you must obtain before assembling the PCCO90X include but are not limit to:

- Standard Wrench Set
- Metric Wrench Set
- Adjustable Wrench
- Standard / Metric Allen Key Set

INSTALLATION REQUIREMENTS

Follow these installation requirements when assembling the PCCO90X:

Set up the PCCO90X on a solid, flat surface. A smooth, flat surface under the machine helps keep it level.

Provide ample space around the machine. Open space around the machine allows for easier access.

For aesthetic purposes, insert all bolts in the same direction unless specified (in text or illustrations) to do otherwise.

Leave room for adjustments. Tighten fasteners such as bolts, nuts, and screws so the unit is stable, but leave room for adjustments. Do not fully tighten fasteners until instructed in the assembly steps to do so.

Fill out and mail the warranty card.

ORDERING REPLACEMENT PARTS

If you need to order replacement parts please be prepared to provide the following information when contacting us so that we can assist you better.

1. Model Number
2. Place of Purchase
3. Serial Number (S/N)
4. Part # and Description

ASSEMBLY TIPS

Read all “Notes” on each page before beginning each step.

While you may be able to assemble the PCCO90X using the illustrations only, important safety notes and other tips may be included in the text.

Some pieces may have extra holes that you will not use. Use only those holes indicated in the instructions and illustrations.

NOTE: With so many assembled parts, proper alignment and adjustment is critical. While tightening the nuts and bolts, be sure to leave room for adjustments.

NOTE: The bottles that are marked “Poison” is your touch up paint. Keep away from children.

CAUTION: Obtain assistance! If you feel like you can't assemble the PCCO90X by yourself then do not attempt to do so as this could result in injury. Review the Installation Requirements before proceeding with the following steps.

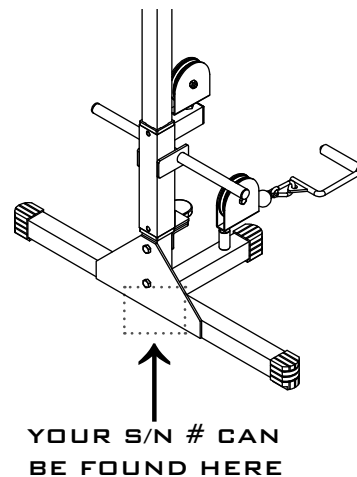

PCC090X

PART LIST

PART #	QTY	DESCRIPTION
A	2	VERTICAL FRAME
B	2	BASE FRAME
C	2	L-BRACKET
D	2	WEIGHT FRAME
E	2	CONNECTING BRACKET
F	1	RIGHT SUPPORT BRACKET
G	1	LEFT SUPPORT BRACKET
H	2	MID PULLEY
I	4	PULLEY HOLDER
J	1	CROSSBEAM A
K	2	CROSSOVER HANDLE
L	1	CROSSBEAM B
M	2	CROSS BEAM CONNECTING BRACKET
1	10	M12x75MM HEX HEAD BOLT
2	2	M12x70MM HEX HEAD BOLT
3	2	M10x75MM HEX HEAD BOLT
4	6	M10x40MM HEX HEAD BOLT
5	12	M12 NYLON LOCK NUT
6	8	M10 NYLON LOCK NUT
7	6	1/2" NYLON LOCK NUT
8	2	M12 WASHER
9	4	50x50MM END CAP
10	4	60x50MM NYLON BUSHING
11	4	1" ROUND END CAP
12	8	110MM PULLEY
13	6	50x50MM FOOT CAP
14	2	8MM SNAP LINK
15	2	50MM RUBBER CUSHION
16	2	CABLE
17	2	5/8" PULLEY SPACER
21	3	M10x70MM HEX HEAD BOLT
22	6	M10 WASHER

PCC090X

HARDWARE ILLUSTRATION

PART #1

M12X75MM HEX HEAD BOLT

QTY. 10

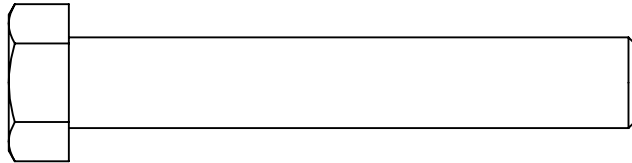

PART #2

M12X70MM HEX HEAD BOLT

QTY. 2

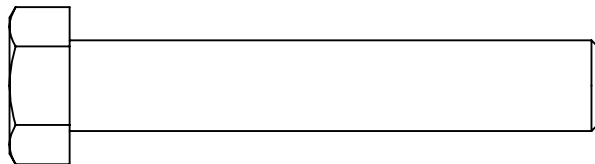

PART #3

M10X75MM HEX HEAD BOLT

QTY. 2

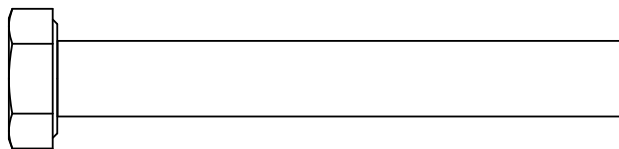

PART #4

M10X40MM HEX HEAD BOLT

QTY. 6

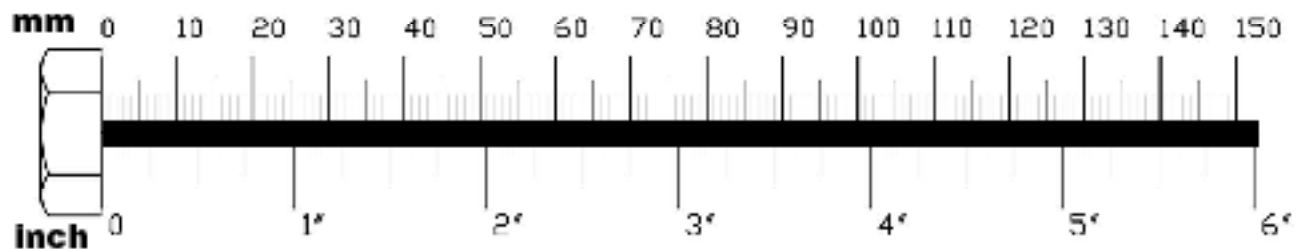
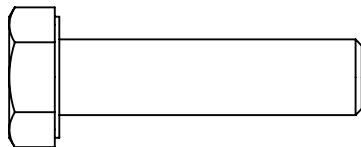

PCC090X

HARDWARE ILLUSTRATION CONT.

PART #5

M12 NYLON LOCK NUT

QTY. 12

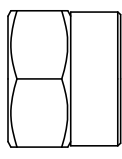

PART #6

M10 NYLON LOCK NUT

QTY. 11

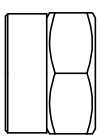

PART #7

1/2" NYLON LOCK NUT

QTY. 6

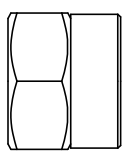

PART #8

M12 WASHER

QTY. 2

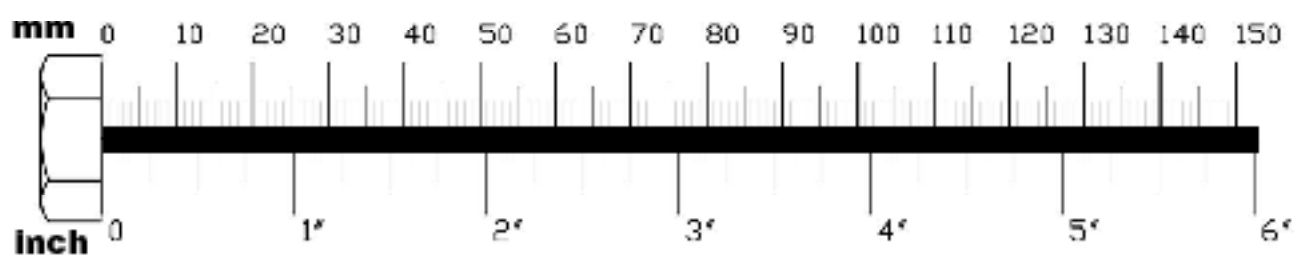
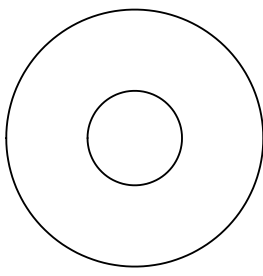

PCC090X

HARDWARE ILLUSTRATION CONT.

PART #21

M10X70MM HEX HEAD BOLT

QTY. 3

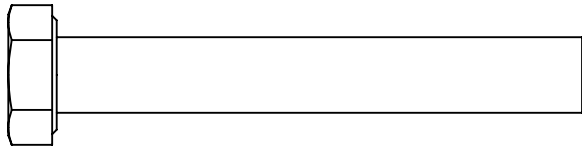

PART #22

M10 FLAT WASHER

QTY. 6

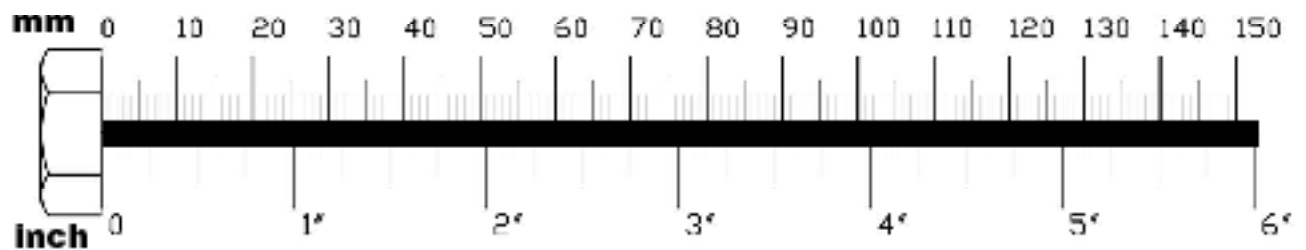
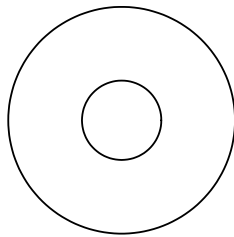

PCC090X

STEP 1

BE CAREFUL TO ASSEMBLE ALL COMPONENTS IN THE SEQUENCE THAT THEY ARE PRESENTED.

NOTE:

FINGER TIGHTEN ALL HARDWARE IN THIS STEP. DO NOT WRENCH TIGHTEN UNTIL THE LAST STEP. SOME COMPONENTS MAY BE PRE-ASSEMBLED.

NYLON LOCK NUTS WILL NOT FULLY SCREW ONTO BOLTS, MUST WRENCH TIGHTEN.

- 1 A. INSERT A FOOT CAP ONTO EACH END OF BOTH BASE FRAMES (B) USING A TOTAL OF
6 - (#13) 50X50MM FOOT CAP

- 1 B. ATTACH A PULLEY HOLDER (I) TO EACH BASE FRAME (B) USING A TOTAL OF:
2 - (#7) 1/2" NYLON LOCK NUT

- 1 C. INSERT A NYLON BUSHING INTO THE TOP AND BOTTOM OPENINGS OF BOTH WEIGHT FRAMES (D) USING A TOTAL OF:
4 - (#10) 60X50MM NYLON BUSHING

- 1 D. INSERT A END CAP INTO THE FRONT OPENINGS OF BOTH WEIGHT FRAMES (D) USING A TOTAL OF
2 - (#9) 50X50MM END CAP

- 1 E. INSERT A ROUND END CAP INTO THE LEFT AND RIGHT OPENINGS OF BOTH WEIGHT FRAMES (D) USING A TOTAL OF:
4 - (#11) 1" ROUND END CAP

- 1 F. INSERT RUBBER CUSHION ONTO THE LOWER LIP OF BOTH WEIGHT FRAMES (D) USING A TOTAL OF:
2 - (#15) 50MM RUBBER CUSHION

- 1 G. ATTACH A MID PULLEY HOLDER (H) TO EACH WEIGHT FRAME (D) USING A TOTAL OF:
2 - (#7) 1/2" NYLON LOCK NUT

PCC090X

STEP 1

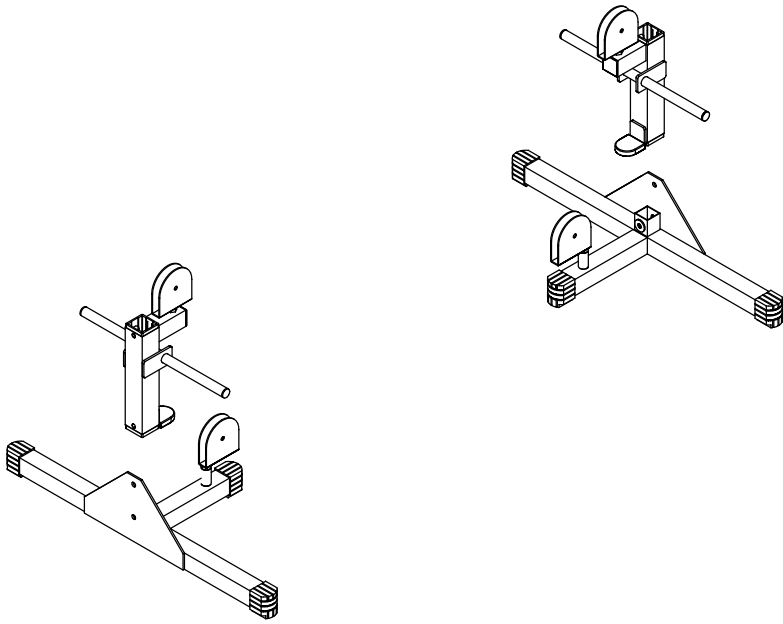

ABOVE SHOWS STEP 1
ASSEMBLED AND COMPLETED

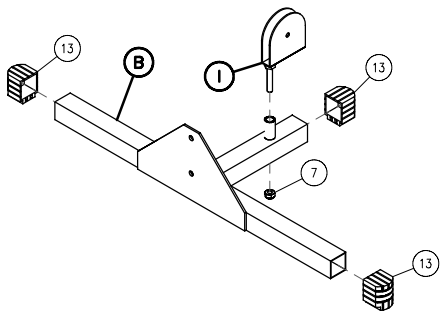
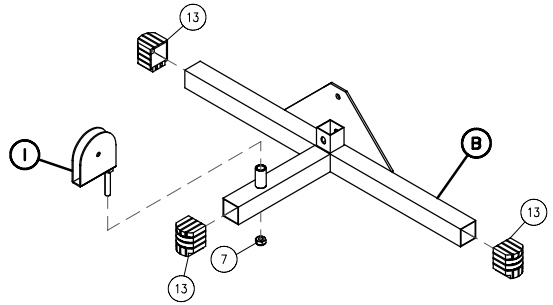
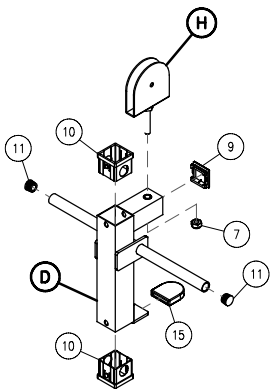
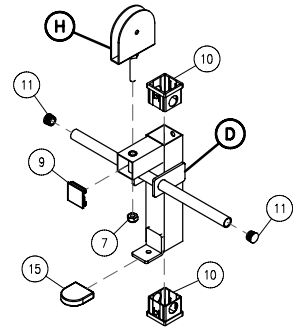

PCC090X

STEP 2

BE CAREFUL TO ASSEMBLE ALL COMPONENTS IN THE SEQUENCE THAT THEY ARE PRESENTED.

NOTE:

FINGER TIGHTEN ALL HARDWARE IN THIS STEP. DO NOT WRENCH TIGHTEN UNTIL THE LAST STEP. SOME COMPONENTS MAY BE PRE-ASSEMBLED.

NYLON LOCK NUTS WILL NOT FULLY SCREW ONTO BOLTS, MUST WRENCH TIGHTEN.

- 2A. FIRST ATTACH A VERTICAL FRAME (A) TO EACH BASE FRAME (B) USING A TOTAL OF:**
- 2 - (#2) M12X70MM HEX HEAD BOLT**
 - 2 - (#8) M12 WASHER**
 - 2 - (#5) M12 NYLON LOCK NUT**
- 2B. SECOND ATTACH A L-BRACKET (C) TO EACH VERTICAL FRAME (A) AND THEN TO EACH BASE FRAME (B) USING A TOTAL OF:**
- 2 - (#1) M12X75MM HEX HEAD BOLT**
 - 2 - (#5) M12 NYLON LOCK NUT**
- 2C. INSERT A END CAP INTO EACH TOP OPENING OF VERTICAL FRAME (A) USING A TOTAL OF:**
- 2 - (#9) 50X50MM END CAP**
- 2D. SLIDE AN ASSEMBLED WEIGHT FRAME (D) ONTO EACH VERTICAL FRAME (A).**
- 2E. ATTACH A PULLEY HOLDER (I) TO LEFT SUPPORT BRACKET (G) AND RIGHT SUPPORT BRACKET (F) USING A TOTAL OF:**
- 2 - (#7) 1/2" NYLON LOCK NUT**

PCC090X

STEP 2

LEFT SHOWS STEP 2
ASSEMBLED AND COMPLETED

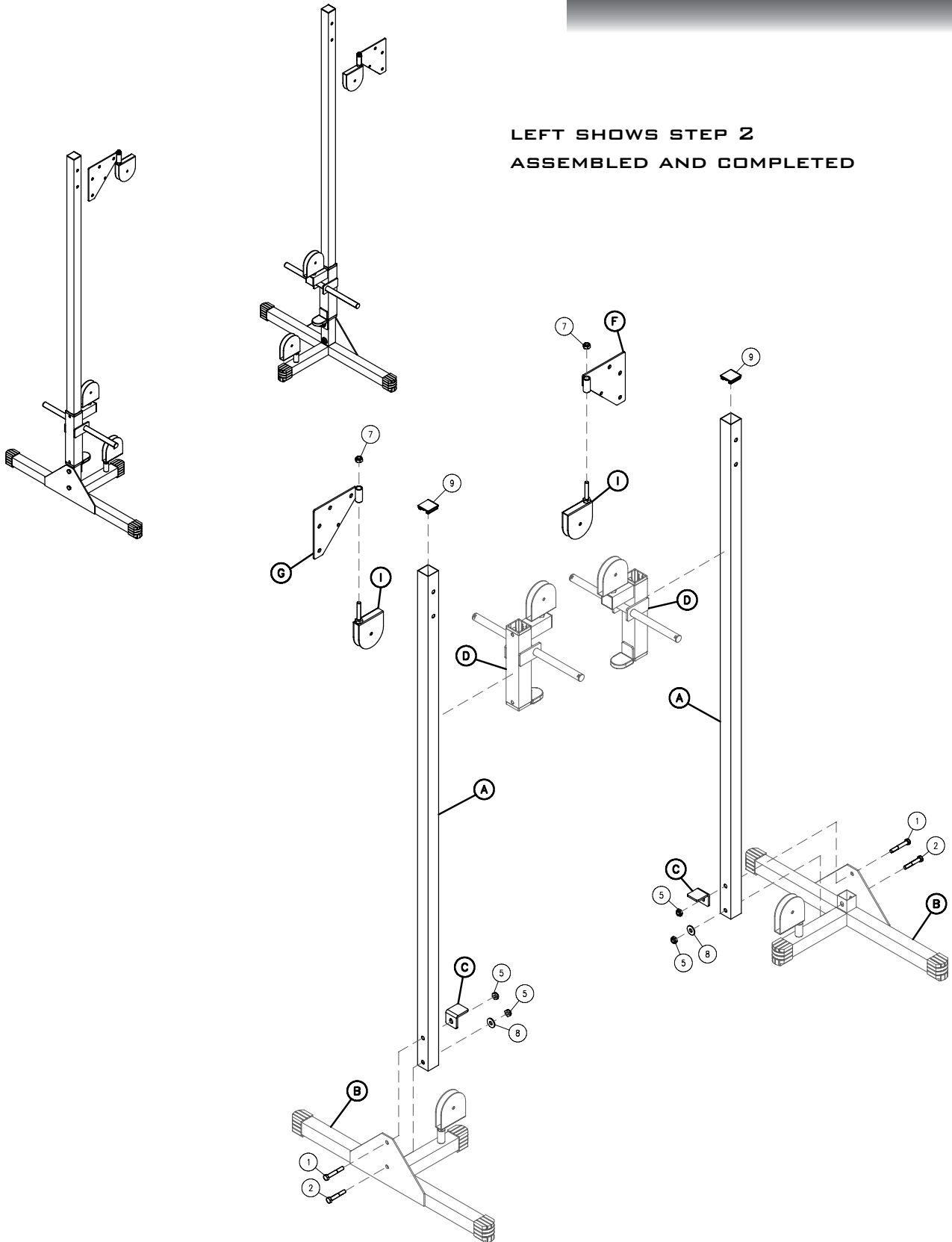

PCC090X

STEP 3

BE CAREFUL TO ASSEMBLE ALL COMPONENTS IN THE SEQUENCE THAT THEY ARE PRESENTED.

NOTE:

FINGER TIGHTEN ALL HARDWARE IN THIS STEP. DO NOT WRENCH TIGHTEN UNTIL THE LAST STEP. SOME COMPONENTS MAY BE PRE-ASSEMBLED.

NYLON LOCK NUTS WILL NOT FULLY SCREW ONTO BOLTS, MUST WRENCH TIGHTEN.

3A. ATTACH CROSSBEAM A (J) TO CROSSBEAM B (L) USING:

3 - (#21) M10X70MM HEX HEAD BOLT

6 - (#22) M10 FLAT WASHER

3 - (#6) M10 NYLON LOCK NUT

2 - (M) CROSS BEAM CONNECTING BRACKET

PCC090X

STEP 3

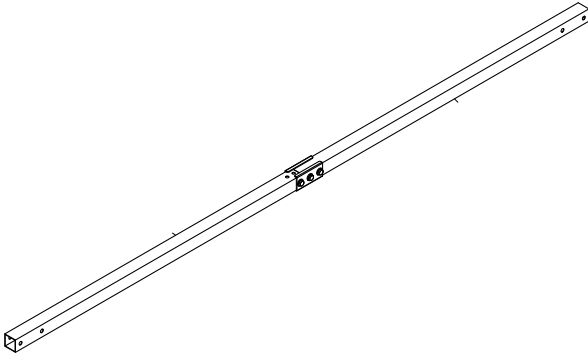

LEFT SHOWS STEP 3
ASSEMBLED AND COMPLETED

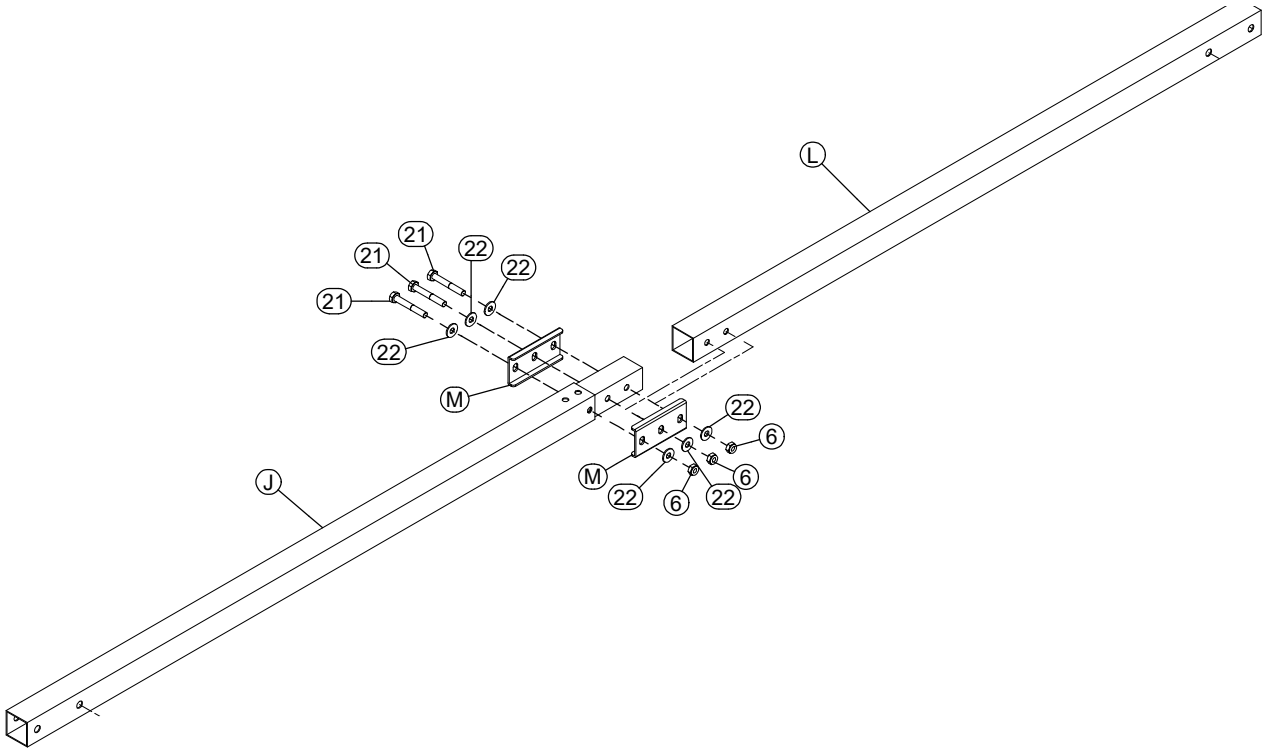

PCC090X

STEP 4

BE CAREFUL TO ASSEMBLE ALL COMPONENTS IN THE SEQUENCE THAT THEY ARE PRESENTED.

NOTE:

FINGER TIGHTEN ALL HARDWARE IN THIS STEP. DO NOT WRENCH TIGHTEN UNTIL THE LAST STEP. SOME COMPONENTS MAY BE PRE-ASSEMBLED.

4A. ATTACH CROSS BEAM (J) TO THE VERTICAL FRAME (A) ON THE LEFT SIDE USING LEFT SUPPORT BRACKET (G) AND A CONNECTING BRACKET (E) USING A TOTAL OF:

4 - (#1) M12X75MM HEX HEAD BOLT

4 - (#5) M12 NYLON LOCK NUT

4B. ATTACH CROSS BEAM (L) TO THE VERTICAL FRAME (A) ON THE RIGHT SIDE USING RIGHT SUPPORT BRACKET (F) AND A CONNECTING BRACKET (E) USING A TOTAL OF:

4 - (#1) M12X75MM HEX HEAD BOLT

4 - (#5) M12 NYLON LOCK NUT

PCC090X

STEP 4

LEFT SHOWS STEP 4
ASSEMBLED AND COMPLETED

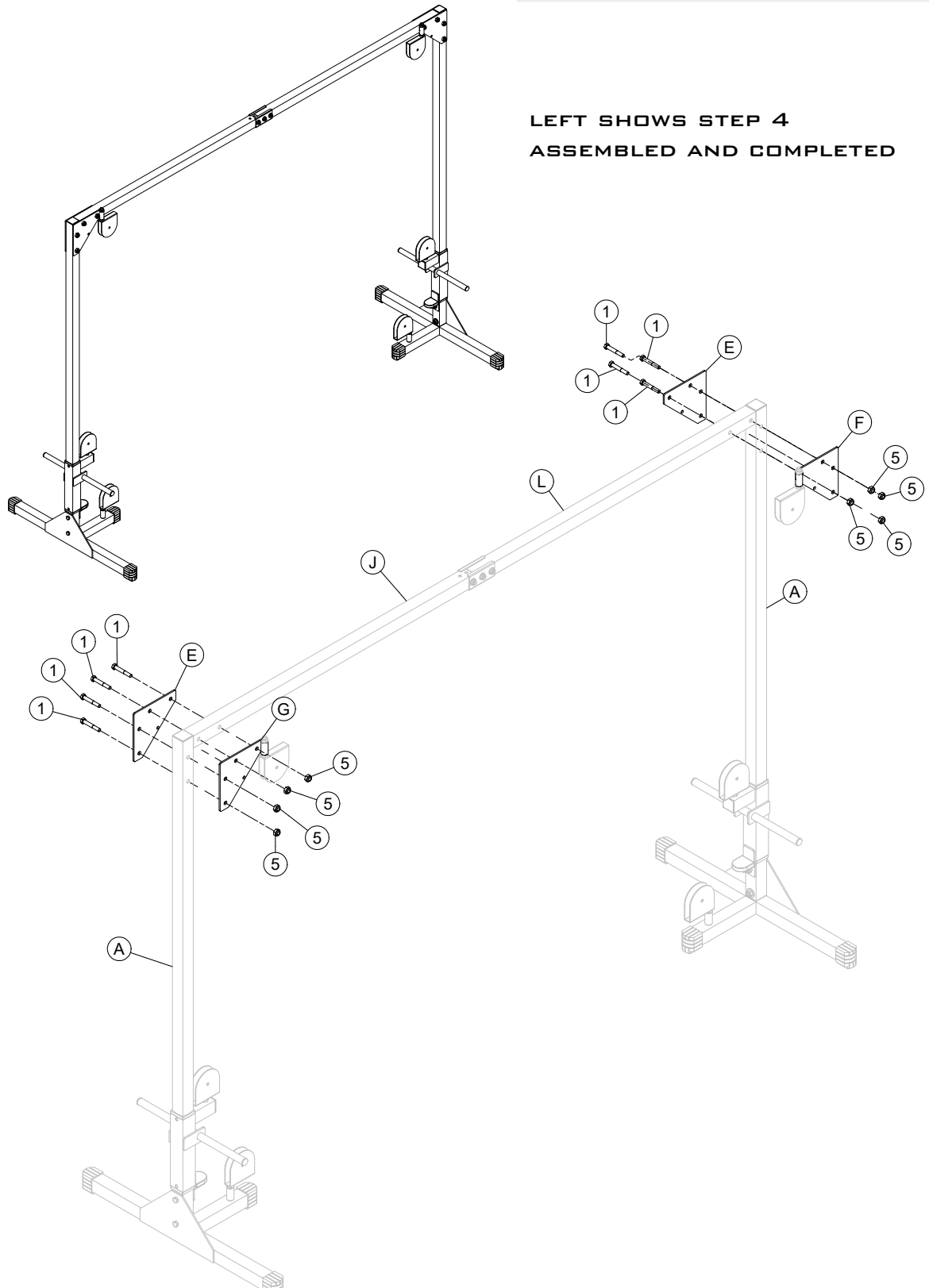

PCC090X

STEP 5

BE CAREFUL TO ASSEMBLE ALL COMPONENTS IN THE SEQUENCE THAT THEY ARE PRESENTED.

NOTE:

THIS STEP IS INTENDED TO SHOW YOU WHERE THE PULLEYS NEED TO BE INSTALLED AND WHAT HARDWARE YOU WILL NEED TO INSTALL THEM. HOWEVER, YOU MUST INSTALL THE PULLEYS THE SAME TIME YOU ROUTE THE CABLES WHICH CAN BE FOUND ON THE NEXT STEP

5A. A PULLEY WILL BE ATTACHED TO BOTH OF THE TWO PULLEY HOLDERS (I) AT THE BASE OF YOUR PCC090X USING A TOTAL OF:

- 2 - (#12) 110MM PULLEY**
- 2 - (#4) M10X40MM HEX HEAD BOLT**
- 2 - (#6) M10 NYLON LOCK NUT**

5B. A PULLEY WILL BE ATTACHED TO BOTH OF THE TWO MID PULLEY HOLDERS (H) ATTACHED TO THE WEIGHT FRAMES (D) USING A TOTAL OF:

- 2 - (#12) 110MM PULLEY**
- 2 - (#4) M10X40MM HEX HEAD BOLT**
- 2 - (#6) M10 NYLON LOCK NUT**

5C. A PULLEY WILL BE ATTACHED TO BOTH OF THE TWO MID PULLEY HOLDERS (H) AT THE TOP OF YOUR PCC090X USING A TOTAL OF:

- 2 - (#12) 110MM PULLEY**
- 2 - (#4) M10X40MM HEX HEAD BOLT**
- 2 - (#6) M10 NYLON LOCK NUT**

5D. A PULLEY WILL BE ATTACHED IN BETWEEN THE CONNECTING BRACKETS (E) AND LEFT SUPPORT BRACKET (G) AND RIGHT SUPPORT BRACKET (F) USING A TOTAL OF:

- 2 - (#12) 110MM PULLEY**
- 2 - (#17) 5/8" PULLEY SPACER**
- 2 - (#3) M10X75MM HEX HEAD BOLT**
- 2 - (#6) M10 NYLON LOCK NUT**

PCC090X

STEP 5

LEFT SHOWS STEP 5
ASSEMBLED AND COMPLETED

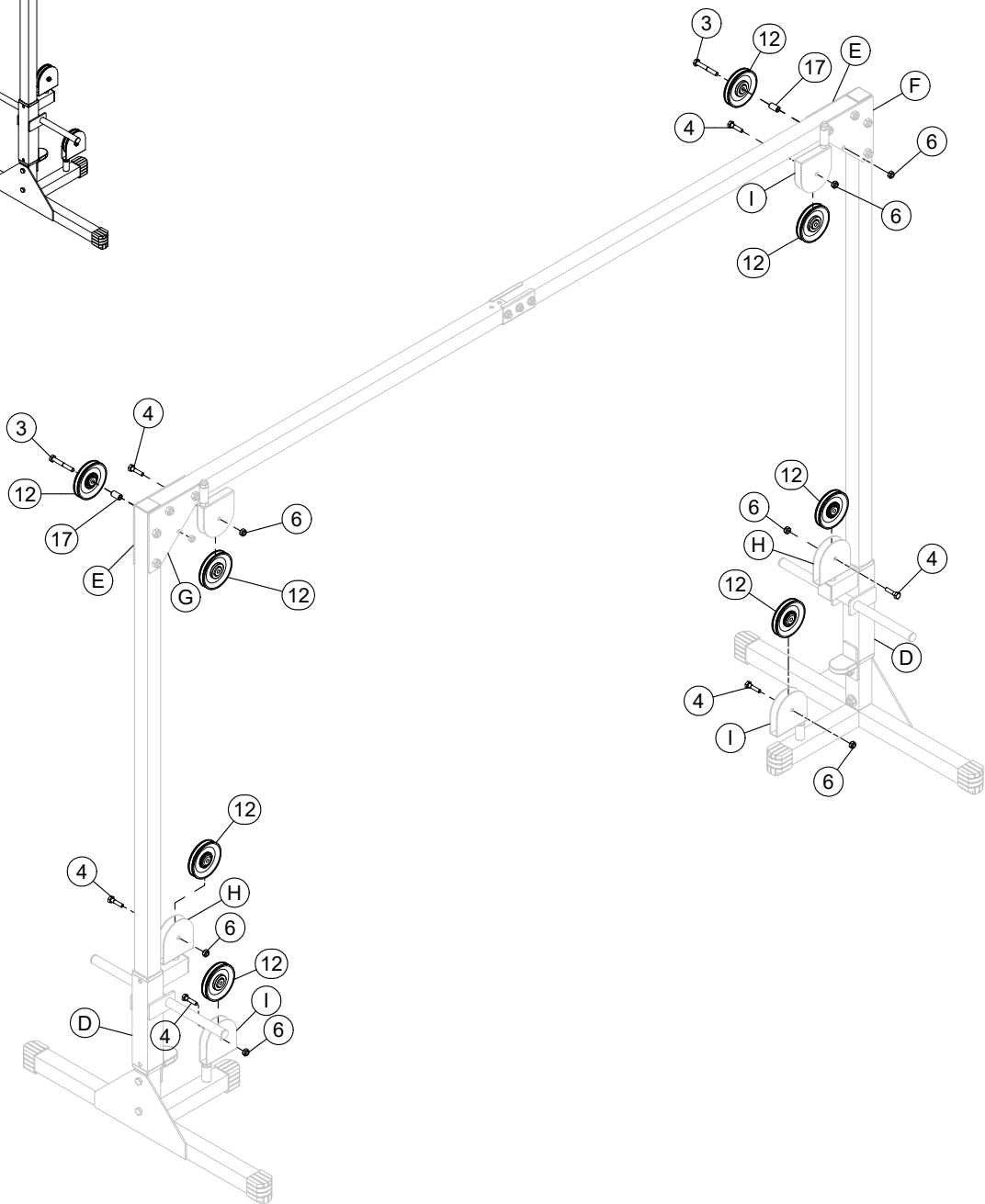
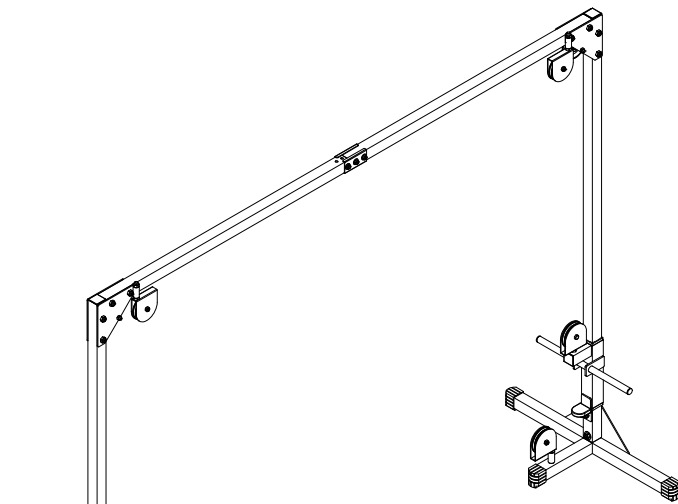

PCC090X

STEP 6

BE CAREFUL TO ASSEMBLE ALL COMPONENTS IN THE SEQUENCE THAT THEY ARE PRESENTED.

NOTE:

THIS STEP IS INTENDED TO SHOW YOU WHERE THE PULLEYS NEED TO BE INSTALLED AND WHAT HARDWARE YOU WILL NEED TO INSTALL THEM. HOWEVER, YOU MUST INSTALL THE PULLEYS THE SAME TIME YOU ROUTE THE CABLES WHICH CAN BE FOUND ON THE NEXT STEP FOUND ON THE NEXT STEP

- 6A. LEFT SIDE CABLE (5170MM, #16) - (L1), INSTALL AND ROUTE THE CABLE AROUND THE PULLEY AND UP TO (L2). (L2), INSTALL AND ROUTE THE CABLE AROUND THE PULLEY AND THEN DOWN TO (L3). (L3), INSTALL AND ROUTE THE CABLE AROUND THE PULLEY AND THEN UP TO (L4). (L4), INSTALL AND THE ROUTE THE CABLE AROUND THE FINAL PULLEY TO COMPLETE THE LEFT SIDE CABLE ROUTING.**
- 6B. RIGHT SIDE CABLE (5170MM, #16) - (R1), INSTALL AND ROUTE THE CABLE AROUND THE PULLEY AND UP TO (R2). (R2), INSTALL AND ROUTE THE CABLE AROUND THE PULLEY AND THEN DOWN TO (R3). (R3), INSTALL AND ROUTE THE CABLE AROUND THE PULLEY AND THEN UP TO (R4). (R4), INSTALL AND THE ROUTE THE CABLE AROUND THE FINAL PULLEY TO COMPLETE THE RIGHT SIDE CABLE ROUTING.**
- 6C. ATTACH A SNAP LINK FOLLOWED BY A CROSSOVER HANDLE (K) TO THE LEFT AND RIGHT SIDE CABLE AT L1 AND R1 USING A TOTAL OF:**
- 2 - (#14) 8MM SNAP LINK**

PCC090X

STEP 6

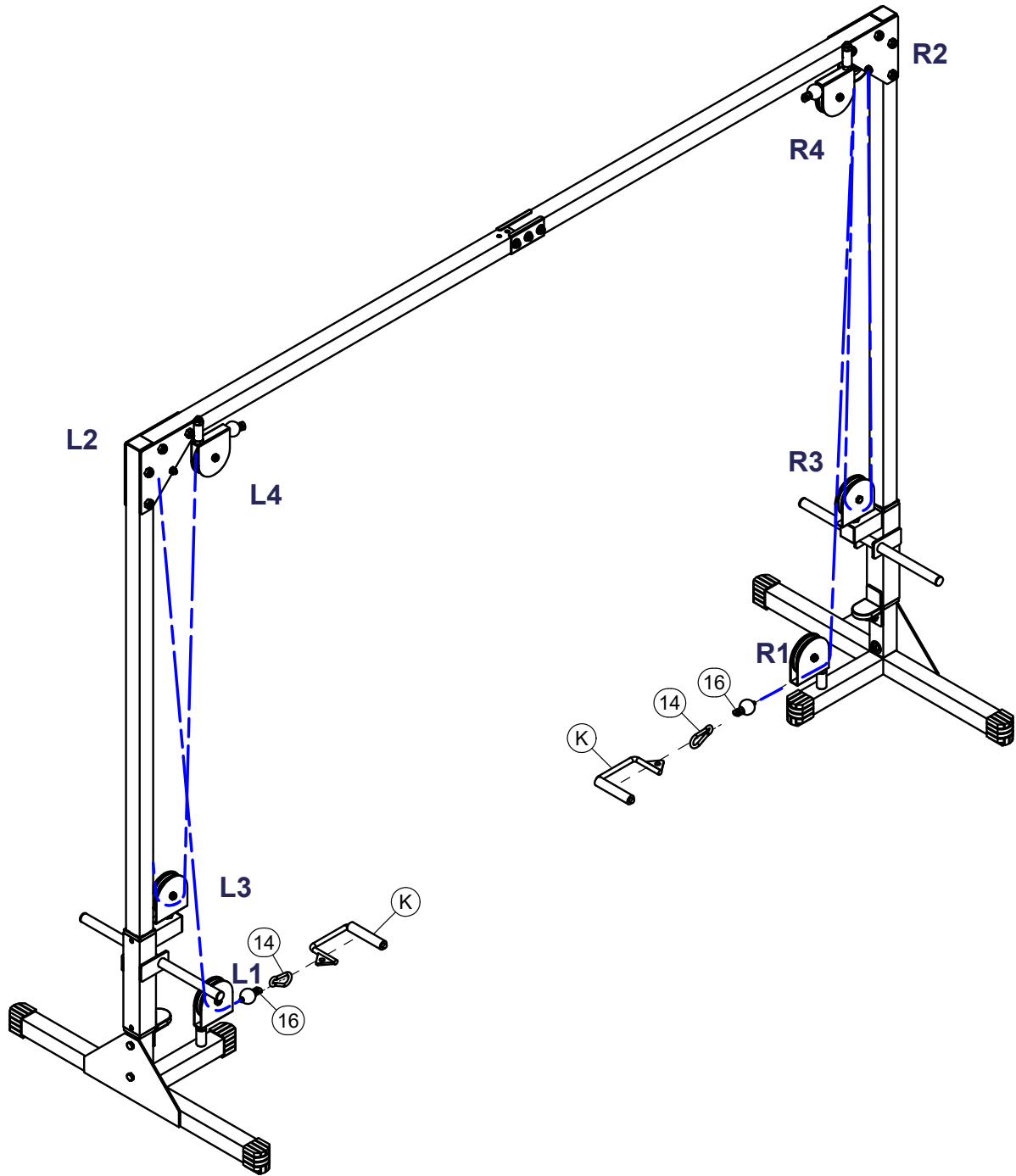

PCC090X
NOTE

PCC090X

EXPLODED VIEW

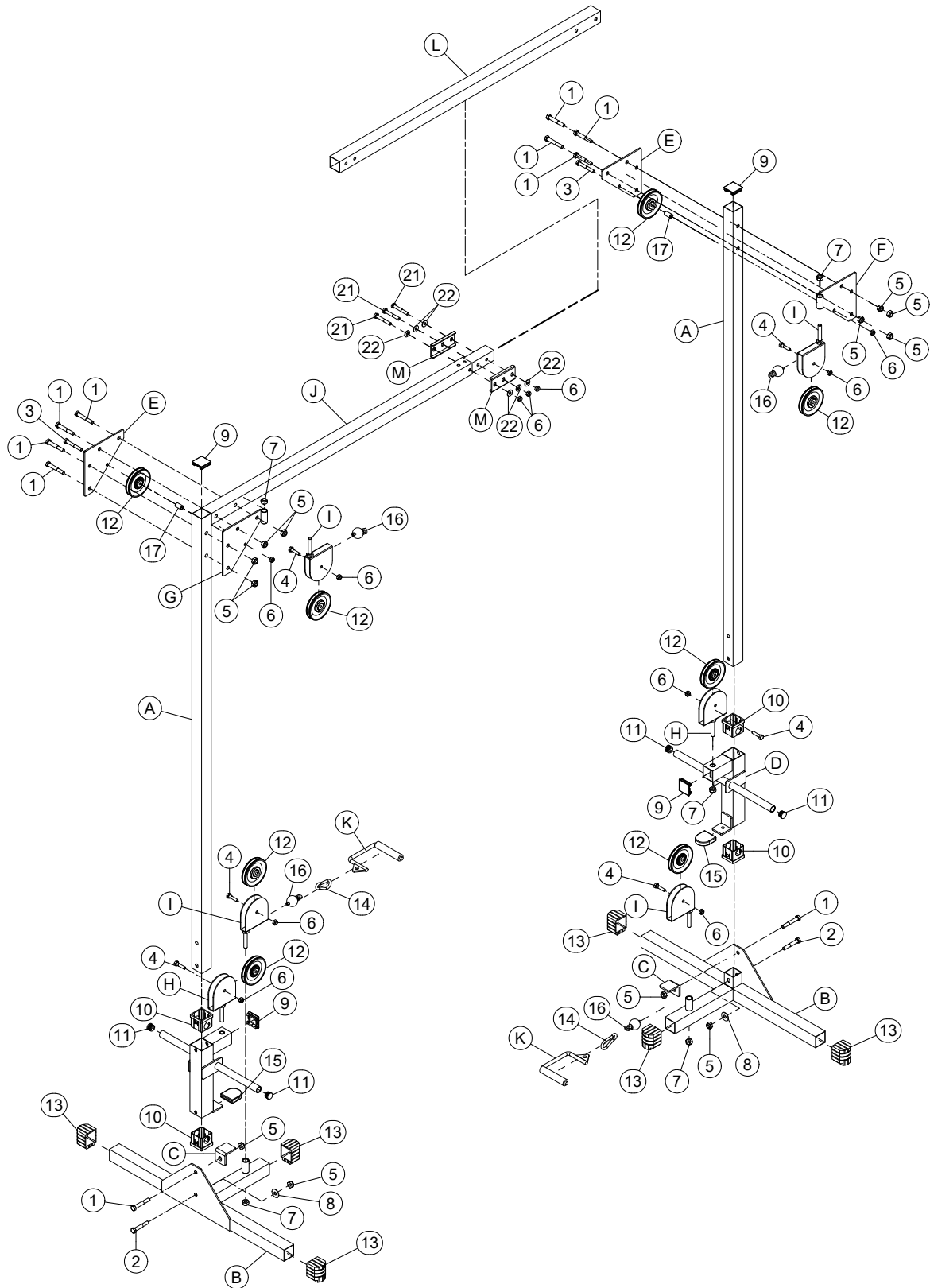

POWERLINE®

by *Body-Solid*

PCC090X

PLEASE WRITE YOUR SERIAL NUMBER IN THE BOXES BELOW

S/N # 013964-□□-□□-□□□□-□□□□

**1900 S. Des Plaines Ave.
Forest Park, IL 60130
Phone:(708)427-3555
Fax:(708)427-3556
Hours: M-F 8:30 - 5:00 CST**