

V. BFLA100-070517

# **BFLA100**

## **OWNER'S MANUAL**

# WARNING, SAFETY, & MAINTENANCE

**THERE IS A RISK ASSUMED BY INDIVIDUALS WHO USE THIS TYPE OF EQUIPMENT. TO MINIMIZE RISK, YOU MUST FOLLOW THESE RULES:**

Inspect equipment before each workout. Check that all nuts, bolts, screws and pop pins are in place and fully tightened. Also, before use, check cables for sign of wear. Replace all worn parts immediately. Never use machine if any parts are damaged or missing.

**FAILURE TO FOLLOW THESE RULES MAY RESULT IN SERIOUS INJURY.**

Keep clear of the cables and all moving parts when machine is in use.

Always make sure all Snap Links are closed when doing cable/pulley/strap exercises.

Exercise with care. Perform your exercises at a smooth moderate pace; never perform jerky or uncoordinated movements that may cause injury.

It is recommended that you workout with a training partner.

Do not allow children or minors to play on or around this equipment.

If unsure of proper use of equipment, call your local Best Fitness distributor or the Best Fitness customer service center at 1-800-556-3113.

**WARNING:** Consult your physician before starting your exercise program. For your own safety, do not begin any exercise program without proper instruction.

## WARNING!

### Safety and Maintenance of Cables

**IMPORTANT:** Cables are wear items. It is your responsibility to prevent unexpected breakage.

**Cable inspection should be performed daily.**

Inspect all cables, the nylon coating on all cables, and the area near fitting at each end of each cable.

**Replace and damaged or worn cable immediately.**

Do not allow the machine to be used until damaged or worn cables are replaced. Using or allowing a machine to be used with a suspect cable can result in serious injury. See Owner's Manual for more information.

For Best Fitness Customer Service  
Call 1-800-556-3113

**DO NOT REMOVE WARNING LABELS FROM MANUAL OR MACHINE**

# TABLE OF CONTENTS

- **SAFETY INSTRUCTIONS** ..... **PAGE 4**
- **PREPARATION** ..... **PAGE 5**
- **HARDWARE LIST** ..... **PAGE 6**
- **HARDWARE ILLUSTRATION** ..... **PAGE 7**
- **PART LIST/ILLUSTRATION** ..... **PAGE 9**
- **ASSEMBLY INSTRUCTIONS** ..... **PAGE 10**
- **EXPLODED VIEW** ..... **PAGE 16**
- **CONTACT PAGE** ..... **PAGE 18**

# IMPORTANT SAFETY INSTRUCTIONS

Before beginning any fitness program, you should obtain a complete physical examination from your physician.

*Il est conseillé de subir un examen médical complet avant d'entreprendre tout programme d'exercice. Si vous avez des étourdissements ou des faiblesses, arrêtez les exercices immédiatement.*

*Antes de comenzar cualquier programa de ejercicios, deberías tener un examen físico con su doctor.*

## **When using exercise equipment, you should always take basic precautions, including the following:**

- Read all instruction before using the **BFLA100**. These instructions are written to ensure your safety and to protect the unit.
- **Do not remove any safety labels from the machine.**
- Do not allow children on or near the equipment.
- Use the equipment only for its intended purpose as described in this guide. Do not use accessory attachments that are not recommended by the manufacturer. Such attachments might cause injuries.
- Wear proper exercise clothing and shoes for your workout, no loose clothing.
- Keep hands, limbs, loose clothing, and long hair well out of the way of all moving parts.
- Use care when getting on or off the unit.
- Do not overexert yourself to work to exhaustion.
- If you feel any pain or abnormal symptoms, stop your workout immediately and consult your physician.
- Never operate the unit when it has been dropped or damaged. Return the equipment to a service center for examination and repair.
- Never drop or insert objects into any opening in the equipment.
- Always check the unit before each use. Make sure that all fasteners are secure and in good working condition.
- Do not use the equipment outdoors or near water.

## **Personal Safety During Assembly**

- Before beginning assembly, please take the time to read the instructions thoroughly.
- Read each step in the assembly instructions and follow the steps in sequence. Do not skip ahead. If you skip ahead, you may learn later that you have to disassemble components and that you may have damaged the equipment.
- Assemble and operate the **BFLA100** on a solid, level surface. Locate the unit a few feet from the walls or furniture to provide easy access.

The **BFLA100** is designed for your enjoyment. By following these precautions and using common sense, you will have many safe and pleasurable hours of healthful exercise with your Best Fitness **BFLA100 Lat Attachment for BFPR100**.

After assembly, you should check all functions to ensure correct operation. If you experience problems, first recheck the assembly instructions to locate any possible errors made during assembly. If you are unable to correct the problem, call the dealer from whom you purchased the machine or call **1-800-556-3113** for the dealer nearest you.

## **Obtaining Service**

Please use this Owner's Manual to make sure that all parts have been included in your shipment. When ordering parts, you must use the part number and description from this Owner's Manual. Use only Best Fitness replacement parts when servicing this machine. Failure to do so will void your warranty and could result in personal injury.

For information about product operation or service, go to [www.bestfitness.com](http://www.bestfitness.com) or contact an authorized Best Fitness dealer or a Best Fitness factory-authorized service company or contact Best Fitness customer service at one of the following:

**Toll Free: 1-800-556-3113**  
**Phone: 1-708-427-3555**  
**Fax: 1-708-427-3556**  
**Hours: M-F 8:30-5:00 CST**  
**E-Mail: [service@bodysolid.com](mailto:service@bodysolid.com)**

**Or write to: Best Fitness  
Service Department  
1900 S. Des Plaines Ave.  
Forest Park, IL 60130 USA**

**Retain this Owner's Manual for future reference. If you need to order replacement parts please be prepared to provide the following information when contacting us so that we can assist you better.**

- 1. Model Number**
- 2. Place of Purchase**
- 3. Serial Number (S/N)**
- 4. Part # and Description**

# PREPARATION

Thank you for purchasing the **BFLA100**. This machine is part of the Best Fitness line of quality strength training machines, which lets you target specific muscle groups to achieve better muscle tone and overall body conditioning. To maximize your use of the equipment please study this Owner's Manual thoroughly.

## **Required Tools**

The basic tools that you must obtain before assembling the **BFLA100** include but are not limited to:

- Metric Allen Key Set
- Standard Allen Key Set
- Standard Wrench Set
- Metric Wrench Set
- Adjustable Wrench
- Screwdriver (standard and/or phillips)

## **Installation Requirements**

Follow these installation requirements when assembling the **BFLA100**:

Set up the **BFLA100** on a solid, flat surface. A smooth, flat surface under the machine helps keep it level. A level machine has fewer malfunctions.

Provide ample space around the machine. Open space around the machine allows for easier access.

Insert all bolts in the same direction. For aesthetic purposes, insert all bolts in the same direction unless specified (in text or illustrations) to do otherwise.

Leave room for adjustments. Tighten fasteners such as bolts, nuts, and screws so the unit is stable, but leave room for adjustments. Do not fully tighten fasteners until instructed in the assembly steps to do so.

**Fill out and mail the warranty card.**

## **Assembly Tips**

Read all "Notes" on each page before beginning each step.

While you may be able to assemble the **BFLA100** using the illustrations only, important safety notes and other tips are included in the text.

Some pieces may have extra holes that you will not use. Use only those holes indicated in the instructions and illustrations.

**NOTE:** With so many assembled parts, proper alignment and adjustment is critical. While tightening the nuts and bolts, be sure to leave room for adjustments.

**NOTE:** The bottles that are marked "Poison" is your touch up paint. Keep away from children.

**CAUTION:** Obtain assistance! If you feel like you can't assemble the **BFLA100** by yourself then do not attempt to do so as this could result in injury. Review the installation requirements before proceeding with the following steps.

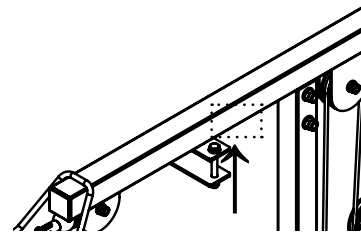

Your S/N# can  
be found here

Best Fitness continually seeks ways to improve the performance, specifications and product manuals in order to ensure that only superior products are released from our factories. Please take the time to carefully read through this manual thoroughly. Instructions contained in this document are not intended to cover all details or variations possible with Best Fitness equipment, or to cover every contingency that may be met in conjunction with installation, operation, maintenance or troubleshooting of the equipment. Even though we have prepared this manual with extreme care, neither the publisher nor the author can accept responsibility for any errors in, or omission from, the information given. Should additional information be required, or should situations arise that are not covered by this manual, the matter should be directed to your local Best Fitness representative, or the Service Department at Body-Solid Inc. in Forest Park, Illinois.

Any Questions?  
Call (800) 556-3113

# HARDWARE LIST

<b>PART #</b>	<b>SIZE</b>	<b>DESCRIPTION</b>	<b>QUANTITY</b>
<b>1</b>	<b>M12X80mm</b>	<b>HEX HEAD BOLT</b>	<b>2 PCS.</b>
<b>2</b>	<b>M12X70mm</b>	<b>HEX HEAD BOLT</b>	<b>2 PCS.</b>
<b>3</b>	<b>M10X80mm</b>	<b>HEX HEAD BOLT</b>	<b>4 PCS.</b>
<b>4</b>	<b>M10X65mm</b>	<b>HEX HEAD BOLT</b>	<b>2 PCS.</b>
<b>5</b>	<b>M10X50mm</b>	<b>HEX HEAD BOLT</b>	<b>5 PCS.</b>
<b>6</b>	<b>M10X25mm</b>	<b>HEX HEAD BOLT</b>	<b>1 PCS.</b>
<b>7</b>	<b>M12</b>	<b>FLAT WASHER</b>	<b>8 PCS.</b>
<b>8</b>	<b>M10</b>	<b>FLAT WASHER</b>	<b>23 PCS.</b>
<b>9</b>	<b>M12</b>	<b>NYLON LOCK NUT</b>	<b>4 PCS.</b>
<b>10</b>	<b>M10</b>	<b>NYLON LOCK NUT</b>	<b>12 PCS.</b>

**Part numbers are required when ordering parts.**

# HARDWARE ILLUSTRATION

**Part #1      HEX HEAD BOLT M12X80mm**

**QTY. 2**

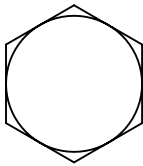
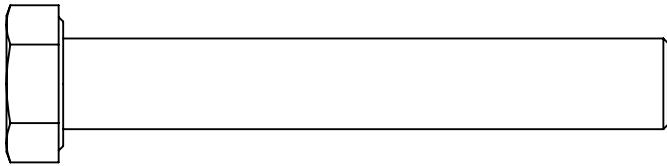

**Part #2      HEX HEAD BOLT M12X70mm**

**QTY. 2**

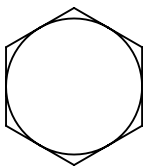
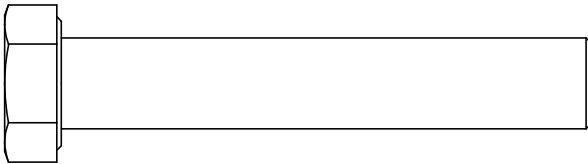

**Part #3      HEX HEAD BOLT M10X80mm**

**QTY. 4**

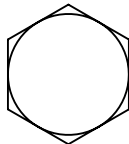
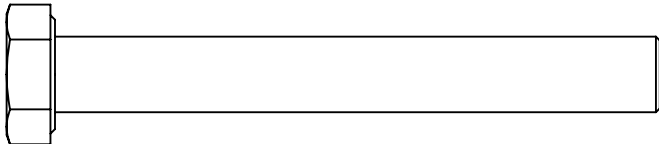

**Part #4      HEX HEAD BOLT M10X65mm**

**QTY. 2**

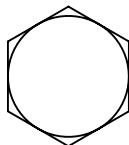
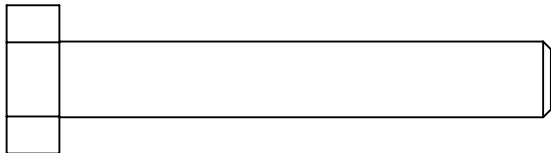

**Part #5      HEX HEAD BOLT M10X50mm**

**QTY. 5**

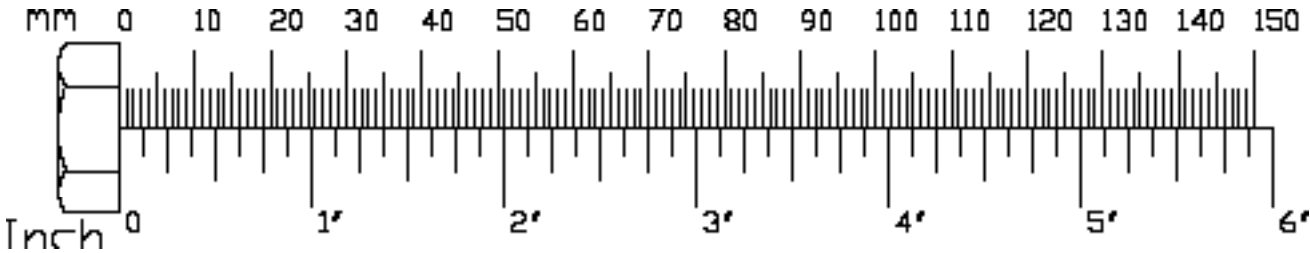
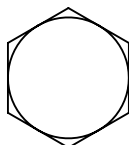
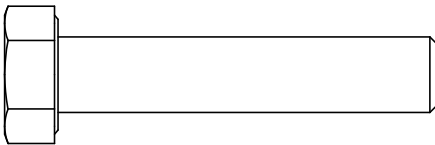

# HARDWARE ILLUSTRATION

**Part #6**

**HEX HEAD BOLT M10X25mm**

**QTY. 1**

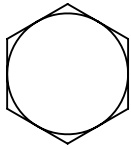
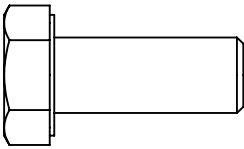

**Part #7**

**FLAT WASHER M12**

**QTY. 8**

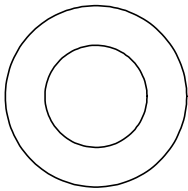

**Part #8**

**FLAT WASHER M10**

**QTY. 23**

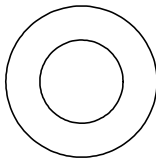

**Part #9**

**NYLON LOCK NUT M12**

**QTY. 4**

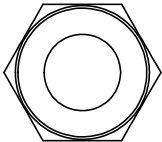
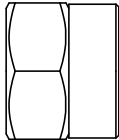

**Part #10**

**NYLON LOCK NUT M10**

**QTY. 12**

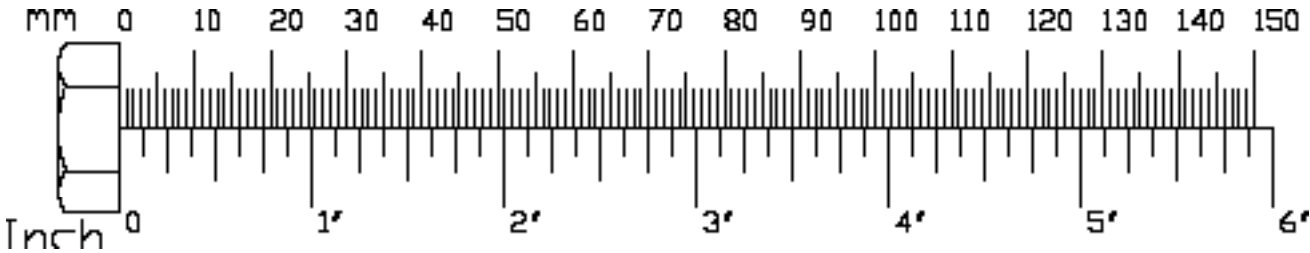
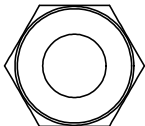
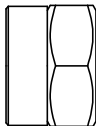



# PART LIST

<b>PART #</b>	<b>DESCRIPTION</b>	<b>QUANTITY</b>
<b>A</b>	<b>BASE FRAME</b>	<b>1 PCS.</b>
<b>B</b>	<b>CHROME UPRIGHT</b>	<b>1 PCS.</b>
<b>C</b>	<b>SLIDING FRAME</b>	<b>1 PCS.</b>
<b>D</b>	<b>TOP FRAME</b>	<b>1 PCS.</b>
<b>E</b>	<b>PULLEY BRACKET</b>	<b>2 PCS.</b>
<b>F</b>	<b>LOW ROW BAR</b>	<b>1 PCS.</b>
<b>G</b>	<b>LAT BAR</b>	<b>1 PCS.</b>
<b>11</b>	<b>FOOT CAP</b>	<b>1 PCS.</b>
<b>12</b>	<b>HAND GRIP</b>	<b>4 PCS.</b>
<b>13</b>	<b>SNAP LINK</b>	<b>7 PCS.</b>
<b>14</b>	<b>CHAIN LINK (10 PCS)</b>	<b>1 PCS.</b>
<b>15</b>	<b>PULLEY</b>	<b>7 PCS.</b>
<b>16</b>	<b>PIN</b>	<b>2 PCS.</b>
<b>17</b>	<b>RETAINER RING</b>	<b>2 PCS.</b>
<b>18</b>	<b>CHAIN LINK (4 PCS)</b>	<b>2 PCS.</b>
<b>19</b>	<b>LOW CABLE</b>	<b>1 PCS.</b>
<b>20</b>	<b>TOP CABLE</b>	<b>1 PCS.</b>
<b>21</b>	<b>ROUND PLASTIC CAP</b>	<b>2 PCS.</b>
<b>22</b>	<b>SPRING COLLAR</b>	<b>2 PCS.</b>
<b>23</b>	<b>NYLON BUSHING</b>	<b>1 PCS.</b>
<b>24</b>	<b>STEEL PLATE</b>	<b>1 PCS.</b>
<b>25</b>	<b>PLASTIC END CAP</b>	<b>2 PCS.</b>
<b>26</b>	<b>FOAM COVER</b>	<b>1 PCS.</b>
<b>27</b>	<b>RUBBER BUMPER</b>	<b>1 PCS.</b>

**STEP****1**

**Be careful to assemble all components in the sequence they are presented.**

**NOTE:**

Finger tighten all hardware in this step. DO NOT wrench tighten until the last step. Some components may be pre-assembled. Nylon lock nuts will not fully screw onto bolts, they must be wrench tighten to fully go on.

**1A. Attach Base Frame (A) to Base Frame of Power Rack (P) using:**

**2 - (#3) M10X80mm Hex Head Bolt**

**4 - (#8) M10 Flat Washer**

**2 - (#10) M10 Nylon Lock Nut**

**1B. Install Foot Cap (#11) into Base Frame(A).****1C. Attach Chrome Upright (B) to Base Frame (A) using:**

**2 - (#1) M12X80mm Hex Head Bolt**

**4 - (#7) M12 Flat Washer**

**2 - (#10) M12 Nylon Lock Nut**

**1D. Insert Sliding Frame (C) onto Chrome Upright (B).**

**STEP**

**1**

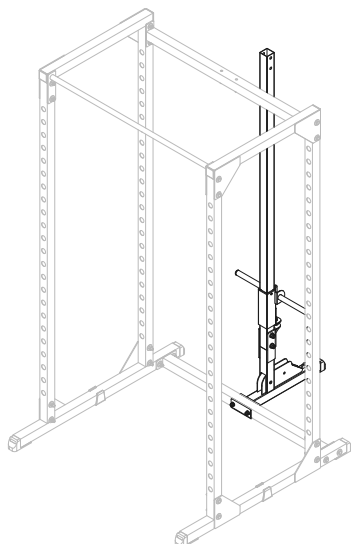

Above shows STEP 1 assembled and completed.

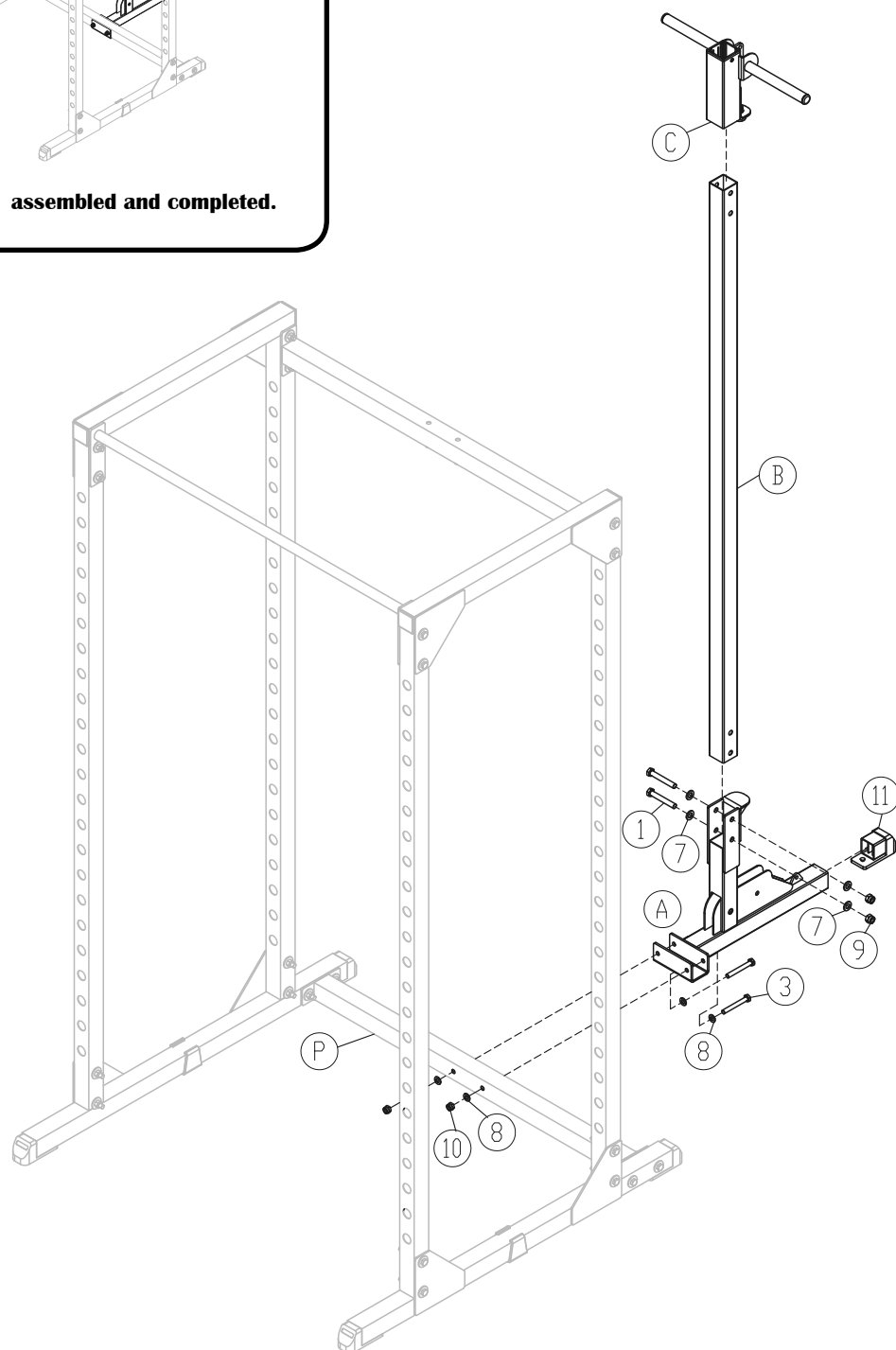

**STEP****2**

**Be careful to assemble all components in the sequence they are presented.**

**NOTE:**

Finger tighten all hardware first in this step. Wrench tighten ALL hardware at the end of STEP 2B. Some components may be pre-assembled. Nylon lock nuts will not fully screw onto bolts, they must be wrench tighten to fully go on.

**2A. Attach Top Frame (D) to Chrome Upright (B) using:**

- 2 - (#2) M12X70mm Hex Head Bolt
- 4 - (#7) M12 Flat Washer
- 2 - (#9) M12 Nylon Lock Nut

**2B. Attach Top Frame (D) to Top Frame of the Power Rack (L) using:**

- 2 - (#3) M10X80mm Hex Head Bolt
- 4 - (#8) M10 Flat Washer
- 2 - (#10) M10 Nylon Lock Nut
- 1 - (#24) Steel Plate

**2C. Route Top Cable (#20) and install four Pulleys (#15) as shown in Step 2 Drawing using:**

- 4 - (#5) M10X50mm Hex Head Bolt
- 8 - (#8) M10 Flat Washer
- 4 - (#10) M10 Nylon Lock Nut
- 2 - (E) Steel Plate

**2D. Attach Chain (4pcs) Link (#18) to the eyelet end of Top Cable (#20)****2E. Attach Chain (4pcs) Link (#18) to Sliding Frame (C).****2F. Route Low Cable (#19) and install three Pulleys (#15) as shown in Step 2 Drawing using:**

- 1 - (#5) M10X50mm Hex Head Bolt
- 2 - (#4) M10X65mm Hex Head Bolt
- 6 - (#8) M10 Flat Washer
- 3 - (#10) M10 Nylon Lock Nut
- 2 - (E) Steel Plate

**2G. Attach Chain Link (#18) to the eyelet end of Low Cable (#19)****2H. Attach Chain Link (#18) to Base Frame (A).**

**STEP**

**2**

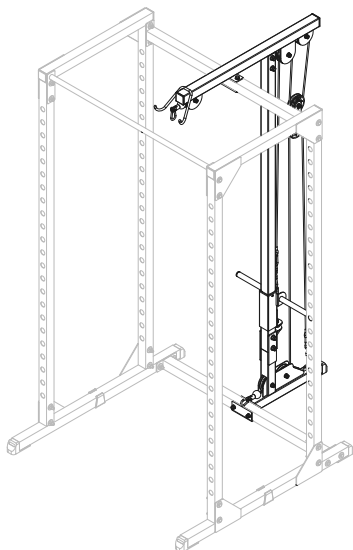

Above shows STEP 2 assembled and completed.

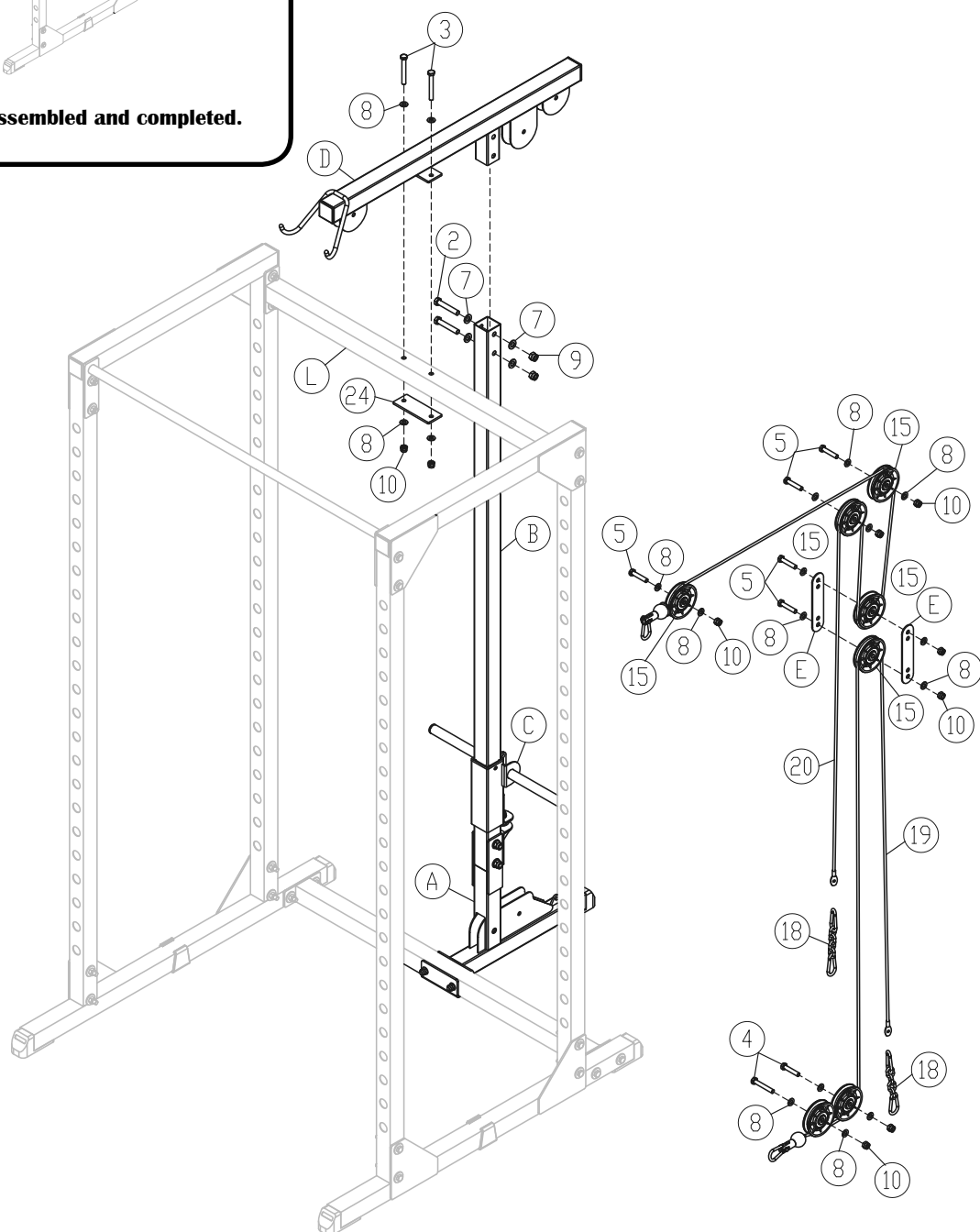

**STEP****3**

**Be careful to assemble all components in the sequence they are presented.**

**NOTE:**

**Some components may be pre-assembled. Nylon lock nuts will not fully screw onto bolts, they must be wrench tighten to fully go on.**

- 3A. Attach Lat Bar (G) to Top Cable (#20).**
- 3B. Attach Low Row Bar (F) to Low Cable (#19).**

STEP

3

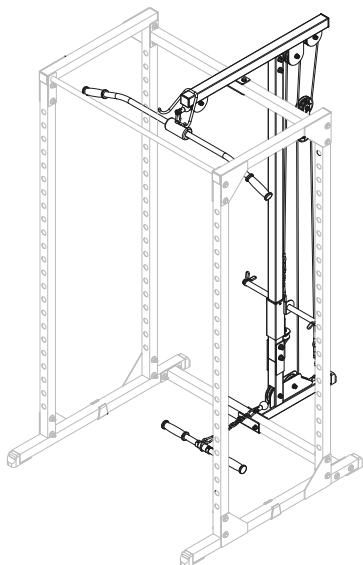

Above shows STEP 3 assembled and completed.

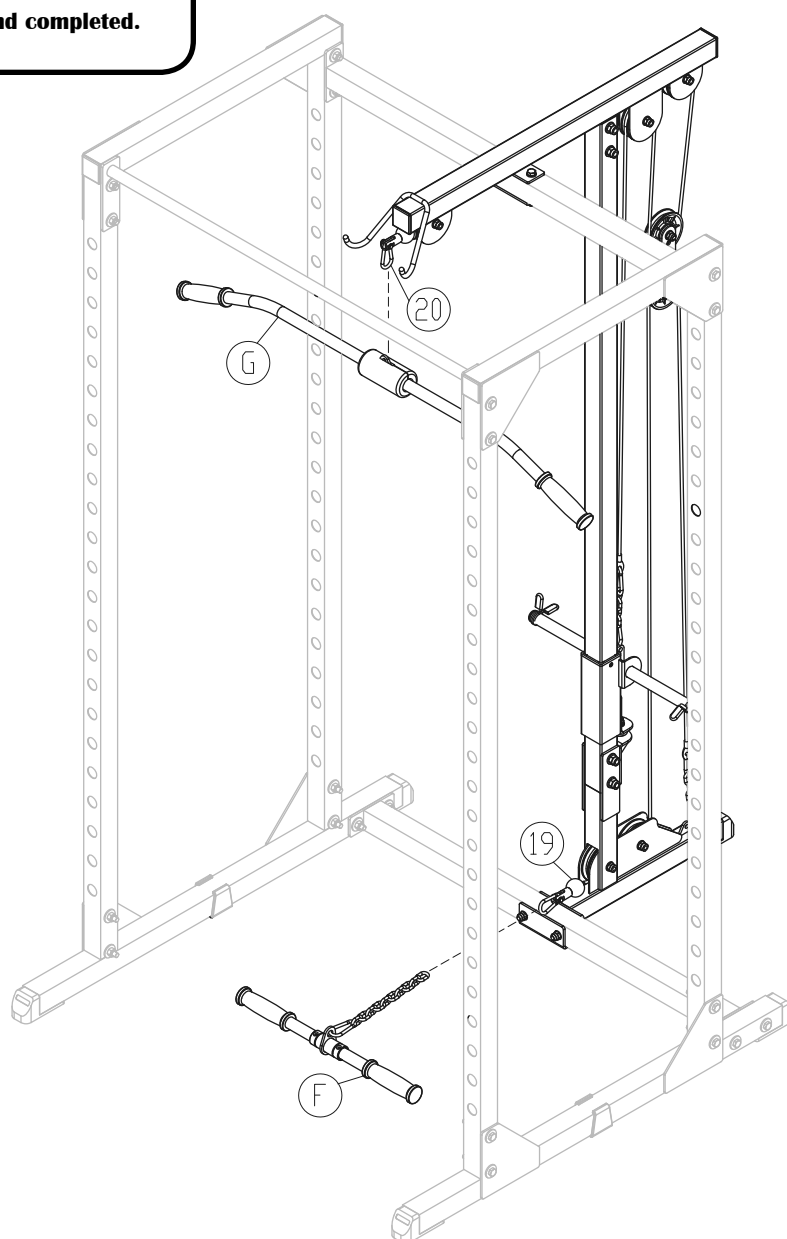

# EXPLODED VIEW DIAGRAM

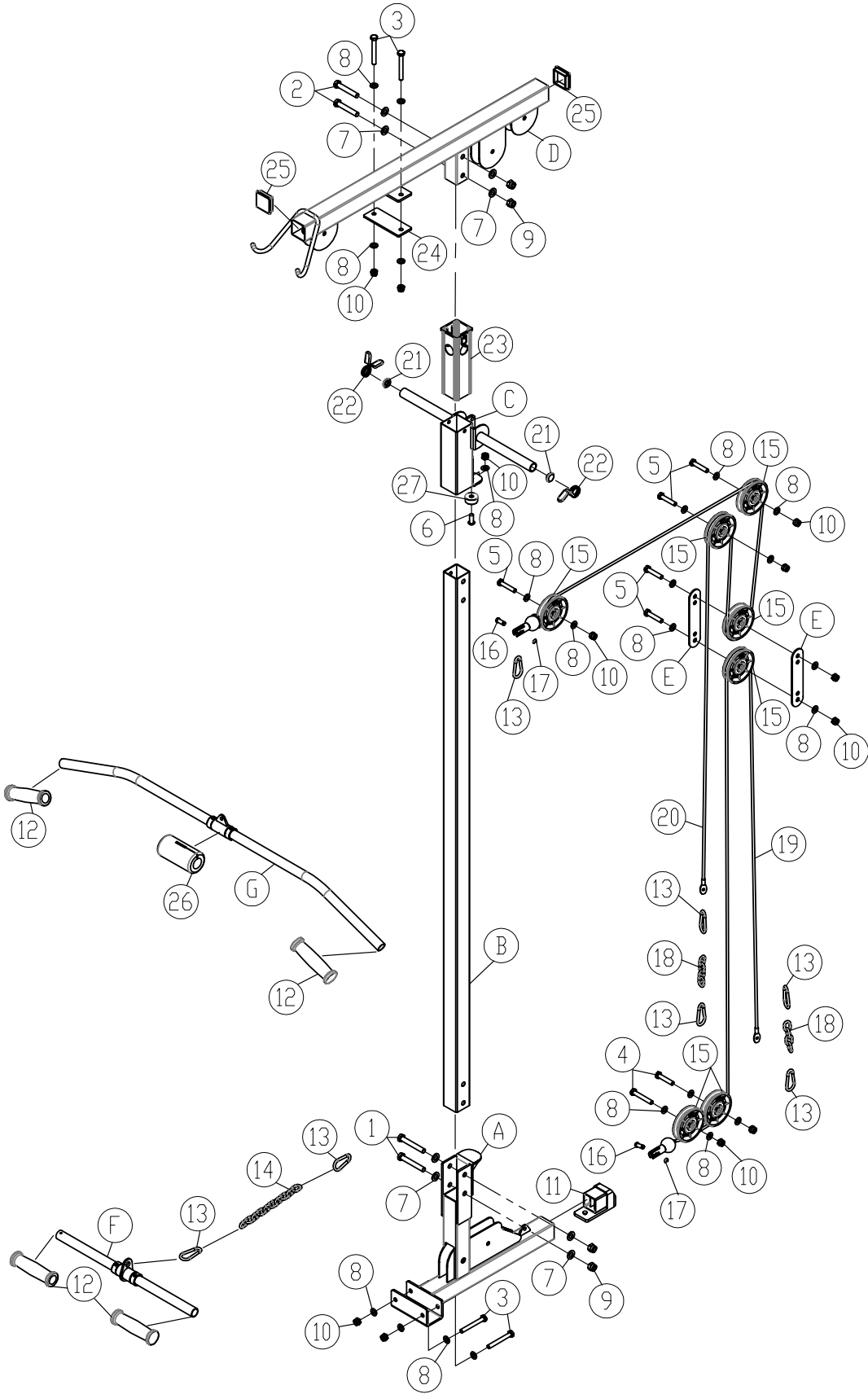





# BFLA100

**PLEASE WRITE YOUR SERIAL NUMBER IN THE BOXES BELOW**

**S/N # 012912-**   -   -     -

1900 S. Des Plaines Ave.  
Forest Park, IL 60130  
1 (800) 556-3113  
Hours: M-F 8:30 - 5:00 CST

