



THE AIR MOVEMENT SPECIALISTS

Please read all instructions before commencing installation.

IMPORTANT

This integrated bathroom heat-fan-light unit must be installed by a registered electrician and its installation and connection to the power supply must comply with all current Australian and New Zealand electrical and building regulations including AS/NZS3000, or latest edition thereof.

The power supply cable must be suitably rated by a registered electrician to satisfy the total load on that circuit.

**MADRID Fan Heater, Light and Exhaust
MODEL: MAD31FHLX**



FOR YOUR SAFETY

- Use this heat-fan-light unit only as described in this manual. Any other use not recommended by the manufacturer may cause fire, electric shock, or injury to persons. If you have questions, contact the manufacturer or local agent.
- To prevent electrical shock, please ensure that power is DISCONNECTED before installing.
- All wiring must be carried out by a licensed electrician in accordance with all national wiring codes.
- When cutting into the ceiling, do not damage electrical wiring and other hidden utilities.
- The heat-fan-light unit must be properly earthed.
- This appliance is not intended for use by persons (including children) with reduced physical, sensory or mental capabilities, or lack of experience and knowledge, unless they have been given supervision or instruction concerning use of the appliance by a person responsible for their safety.
- Children should be supervised to ensure that they do not play with the unit.
- The surface is extremely hot when in use. Allow surface to cool sufficiently before touching or replacement.
- Exhaust fans may adversely affect the safe operation of burning gas or other fuels (including those in other rooms) due to back flow of combustion gases. These gases can potentially result in carbon monoxide poisoning. After installation of an exhaust fan such as a partition fan or a duct fan the operation of flued gas appliances should be tested by a competent person to ensure that back flow of combustion gases does not occur.
- Any alterations or additions to building wiring must be completed by a licensed electrician or person authorised by legislation to work on the fixed wiring of any electrical installation.

INTRODUCTION AND CONSIDERATIONS

- Read these instructions carefully before installing & using the product.
- Always operate this product from a power source of the same voltage, frequency and rating as indicated on rating label.
- This product is designed for installation in flat ceilings only. Don't mount on a sloping ceiling or a vertical wall.
- Locate and install the product in accordance with the requirements of AS/NZS 3000 and local building codes. Do not install in a location where there is a possibility of water splashing into the heater.

VENTILATION REQUIREMENTS

For the exhaust fan to work efficiently, replacement air of a volume equivalent to what is being extracted must be able to enter the room.

Generally, air would be drawn under the door (20mm undercut), or through a slightly open room. If the room is airtight, the fan will operate poorly. Air flow path should ideally pass over the steam source.

Before commencing any cutting, check in the ceiling space that there are no obstructions such as ceiling joists and that there is sufficient height clearance for the housing. Check that the electrical wiring can be routed from the wall switches to the mounting location.

The appliance shall, under no circumstances, be covered with insulating, or similar, material.

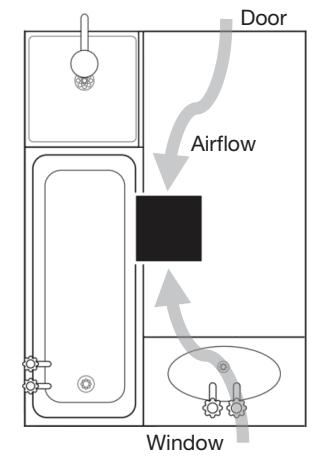

CLEARANCE REQUIREMENTS

- This unit must be mounted at least 250mm away from vertical walls.
- Additionally a minimum of 50mm clearance is required between any part of the Madrid, and Joists, walls, insulation and/or overhead building material.
- Do Not Cover: The Unit must not be covered with building insulation or similar.

WARNING

RISK OF OVERHEATING OR FIRE
IF THE CLEARANCE DISTANCES
ARE COMPROMISED.

Front View

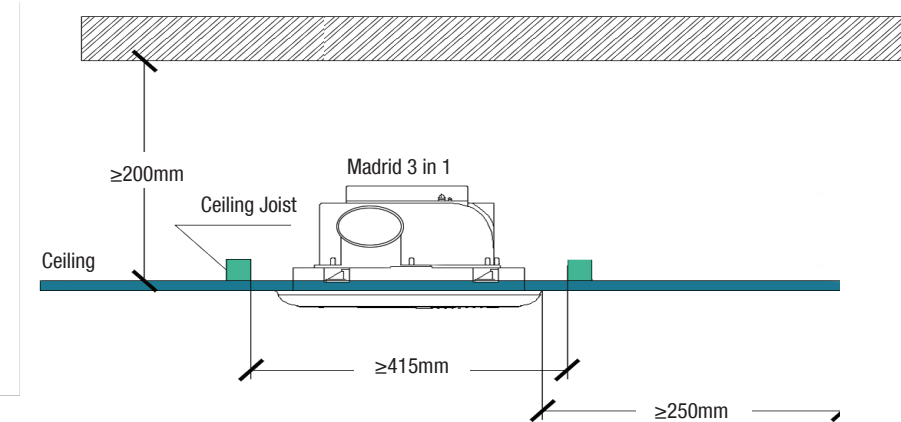

Typical Installation example.

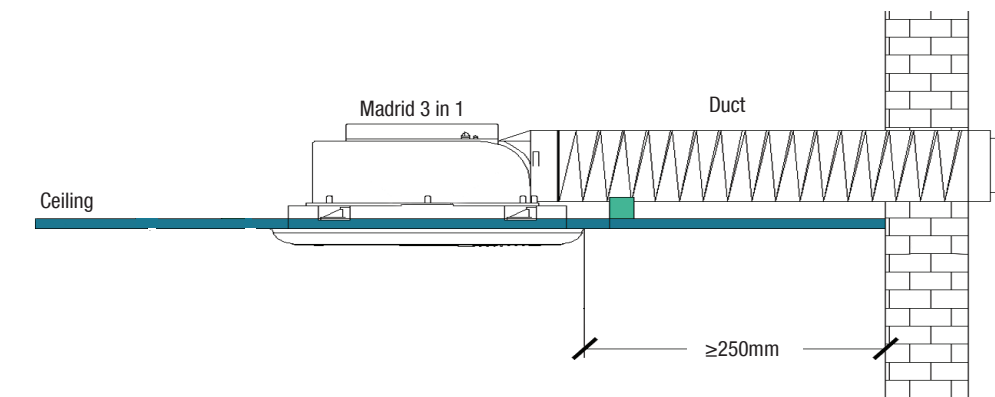

INSTALLATION

- 1 This unit must be mounted at least 2.1 meters above the floor and at least 250mm away from vertical walls.
- 2 Ensure area behind the installation location is clear of all cables, pipes, joists or hidden utilities.
- 3 Use the template provided to mark and cut a hole in the ceiling (Refer specifications for hole size) ensure sufficient space for the clamping arms to operate. Ensure the gap between the clamping arm and lip of the body is slightly larger than the thickness of the ceiling. Adjust accordingly.
- 4 Remove rear terminal cover and connect wires as per wiring diagram below. Refit terminal cover.
Note: Connect ducting (if required) after the unit is installed in the ceiling.
- 5 Gently insert the unit into the cut out hole ensuring to move the side clamping arms inwards so that the body can pass through the hole without damaging the plasterboard. Rotate all 6 clamping arms out using the levers then gently tighten the 6 screws to clamp and secure the unit.
- 6 Connect the LED panel power connector.
- 7 Attach the fascia to the body aligning the "HEATER" marking in the inside of the fascia with the "HEATER" marking on the HFL body and tighten screws avoid overtightening DO NOT use an electric drill or impact driver.
- 8 Attach ducting to extract the air to the soffit or outer wall using 3m long flexible ducting, duct clamp and vent outlet grille provided. Fix and tighten duct clamp firmly to hold the flexible duct to the unit and the outer wall vent. To maximise airflow, cut the duct to size, as required, ensuring it is in a fully expanded state with minimal bends or corners.

ELECTRICAL WIRING DIAGRAM

- 1) Ensure the power is switched “OFF” at the mains before commencing installation.
- 2) Remove the cover on the back of the enclosure to access the terminals.
- 3) Connect wires as per electrical wiring diagram and markings adjacent to terminal block.
- 4) Replace the cover removed earlier.

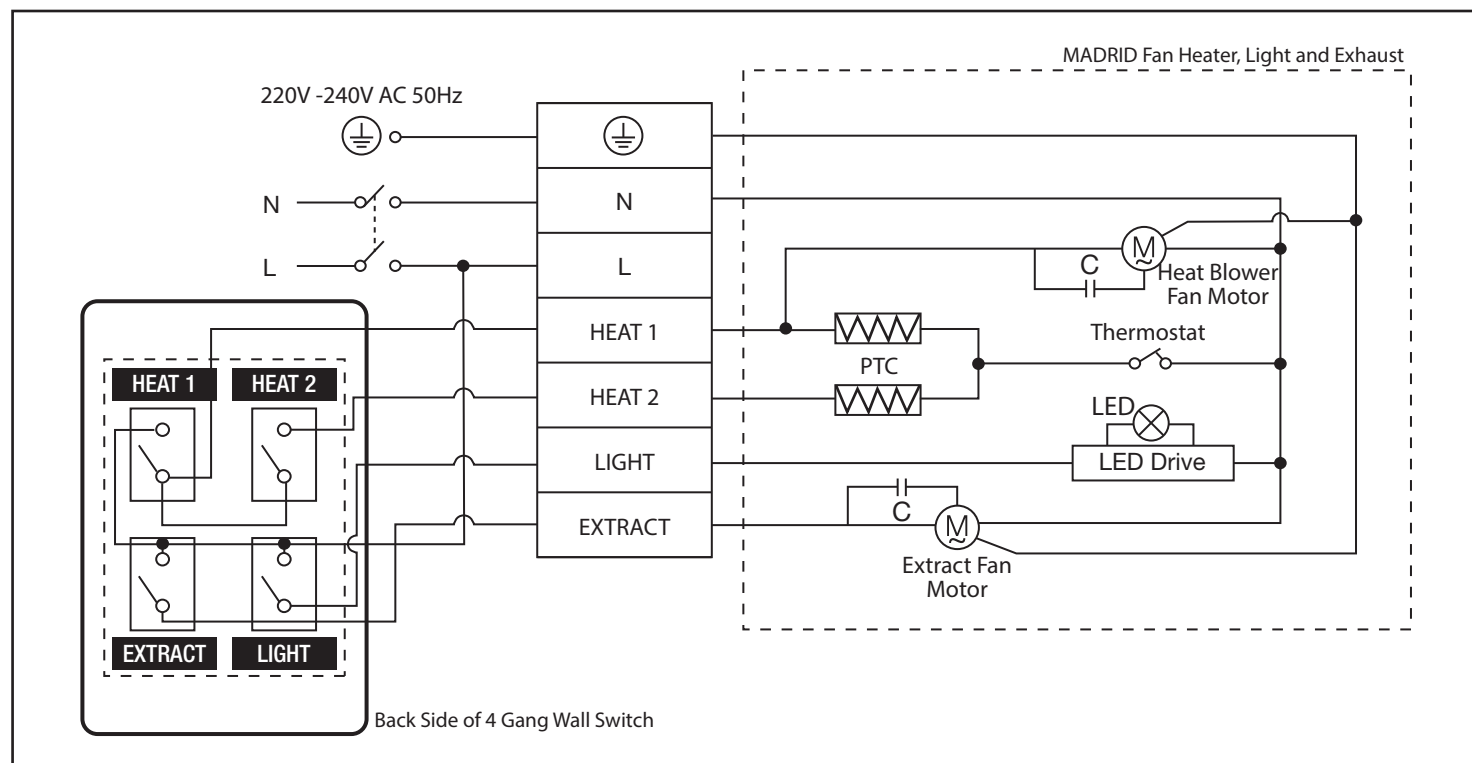

Note: An all pole disconnection must be included in the fixed wiring.

This unit uses PTC heating as a heat source. It also has an extract fan, a heater fan and an LED panel.

The remote switch operation is described below:

1. **Lighting** - “LIGHT” switch turns on and off the LED light panel
2. **Extract** - “EXTRACT” switch On/Off. This unit can exhaust odours and steam in a quick and efficient way by turning on the “EXTRACT” switch.
3. **Heating** - Left “HEAT 1” switch turns on PTC heater and blower fan (1400W)
 Right “HEAT 2” switch boosts the heating power of the PTC heater (2000W).
 The PTC heater and fan will not run if the left “HEAT 1” switch is off.

AIRFLOW AND PRESSURE PERFORMANCE DATA

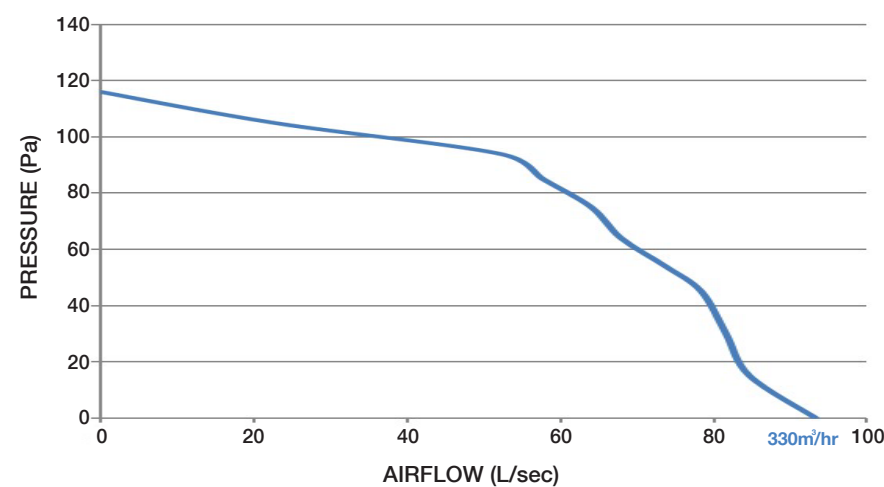

LAMPS

LED panel – DC25-40V, 0.6A, 20W, 1900 lm, Natural White (4000K).

The light source of this luminaire is not replaceable when the light source reaches its end of life the whole luminaire should be replaced.

MAIN TECHNICAL PARAMETERS

Input	Power	Static Pressure	Free Air Fan Performance	Sound Level @ 3m	Hole-cutting Size	IP Rating	Dimensions (W x H x D)	Weight
220-240V AC 50Hz	2100W	115Pa	92 l/s, 330m³/hr	49.5dB(A)	590mm x 320mm	IPX2	350mm x 630mm x 145mm	5.6kg

LIST OF COMPONENTS SUPPLIED

Madrid 3 in 1 - Fan Heater, Light and Exhaust	1 piece
Ø125mm Duct 3m Length	1 piece
Spigot with Gravity Shutter	1 piece
Exterior Grille	1 piece
4 Gang Wall Switch	1 piece
Installation instruction and cutting template	1 piece

CLEANING

- Switch off the power before commencing cleaning and wait until the heater cools down.
- Regularly wipe front fascia with a soft cloth soaked with water or neutral detergent if required.
- Clean the exhaust fan from dust and dirt with dry or wet cloth if required.
- Clean the exhaust ducting kit and ensure airways are clean and there are no obstructions at the exit from the wall.

Instructions are subject to change without notice.

Ventair Pty Ltd
 4 Capital Place, Carrum Downs, VIC, 3201, Australia
 e: info@ventair.com.au | w: www.ventair.com.au