

# Shower Light & Exhaust

INLINE EXHAUST KIT WITH LED LIGHT

- Energy saving LED light
- Long life ball bearing motor
- Easy to install
- Full ducting kit included



LOW MED HIGH



## DIGITAL INFORMATION

Scan here using a QR Code reader application on your smart phone or visit [www.ventair.com.au](http://www.ventair.com.au) for the digital version of this information!



# Shower Light & Exhaust



## INLINE EXHAUST KIT WITH LED LIGHT

150mm Inline exhaust fan kit including a modern internal fascia with 10w LED centre light, External fixed grille and 4m Aluminium Ducting.

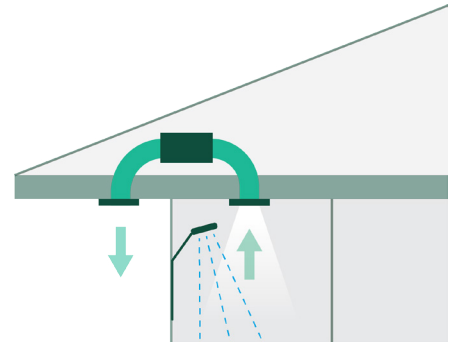

### EXHAUST

**Air Delivery:** 210m<sup>3</sup>H<sup>\*</sup>  
**Motor Power:** 25 watts  
**Noise Level:** 39dB(A)  
**Ball Bearing:** Yes

**Duct Outlet:** 150mm

### LIGHT

**Light Type:** LED Panel  
**Light Wattage:** 10 watts  
**Lumens:** 855Lm  
**Light Colour:** 4200K Natural

### DIMENSIONS

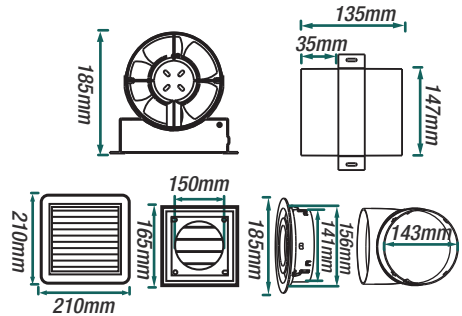

### INSTALLATION

**Cut Out Size:** Ø158mm  
**Recommended Min Install Depth:** 200mm  
**IP Rating:** IPX4  
**Installation:** DIY  
 2 x Plug & Lead

### SHIPPING

**Packaging Size:** 530 x 205 x 225mm  
**Gross Weight:** 3kg  
**Carton Size:** 872 x 550 x 225mm  
**Carton Weight:** 12kg  
**Carton Qty:** 4 units

### INCLUDES

- 1 x Inline exhaust motor
- 1 x External grille
- 1 x Internal air intake grille with LED light
- 1 x 4m Aluminium Ducting (150mm)

### AVAILABLE EXTRAS

- VAD150** 6m Alum Ducting
- VTROTIMER** 1-25min Run-on-Timer
- VTMSSENSOR** 1-20min Motion Sensor
- V150GS** 150mm Gravity Shutter external grille



\*Ventair is leading the Industry by ensuring all airflow data is gathered in accordance with International industry standard ISO 5801.

Model	Colour	Outer Carton	EAN13 Barcode
VEDLKWH	White	19339310006852	9 339310 006855 >



+61 3 9775 0556  
 +61 3 9775 0775  
 sales@ventair.com.au

22 Silkwood Rise, Carrum Downs Vic 3201  
 www.ventair.com.au

WHOLLY AUSTRALIAN OWNED COMPANY

\*Airflow volume listed may show both ISO and non ISO supplied data.  
 • ISO (International Organization for Standardization): An International standard tested under strict guidelines providing accurate data and commonly used in the professional specifying market.  
 • Non ISO: Generic factory supplied data, not tested to strict international standards or guidelines and may vary according to individual manufacturers.