

INSTALLATION INSTRUCTIONS



SENSOR LED MAX LHT0269 BLACK / LHT0270 WHITE Twin 2x 8W LED Sensor Light

Thankyou for purchasing this Simx Lighting Sensor LED light fitting.
This product is suitable for both ceiling or wall installation and sheltered exterior locations.
It requires a 230V AC power supply to operate and should be installed by a registered electrician.

TECHNICAL SPECIFICATIONS

| | | |
|-----------------------|-------------------------------------|-----------------|
| Power Source | 220-240V AC | |
| Rated Load | 17W max | |
| Lumens (per lamp) | 550 lm | |
| Colour Temperature | 3000K Warm White | |
| Light Beam Angle | 95° to half-peak intensity | |
| Detection Range | 8m ± 2 m | |
| Detection Angle | 140° at 3 metres 90° at 8 metres | |
| Time Setting | Min | 30 sec ± 10 sec |
| | Max | 6 min ± 2 min |
| Dusk Control | Day to night (adjustable) | |
| PIR Aiming Adjustment | Pan only, 90° left and right | |
| Working Temperature | -20°C - 40°C | |
| Protection Rating | IP55 | |
| Safety | Class II | |
| Construction | UV-Stabilised Polycarbonate | |

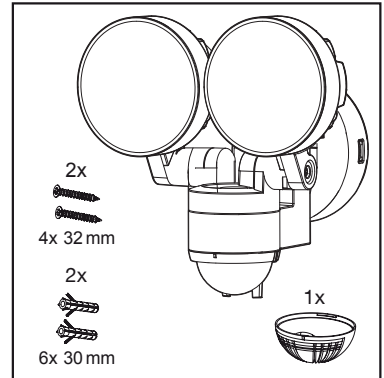

! IMPORTANT

This product is suitable for use only with a supply voltage of 220-240V AC 50Hz.

All electrical work must be carried out in accordance with local and national electrical codes as applicable.
We strongly recommend that this light fitting is installed by a registered electrician.

Always switch power off prior to installation. A means of mains power isolation must be installed in the circuit for the purpose of safe access for any internal cleaning, recalibration, or maintenance.

This light fitting is not intended for use by persons (including children) with reduced physical, sensory or mental capabilities, or lack of experience and knowledge, unless they have been given supervision or instruction concerning use of the appliance by a person responsible for their safety. Young children should be supervised to ensure that they do not play with the appliance.

Any changes or modifications made or attempted to this product, or product installed contrary to these installation instructions without the prior written approval of the manufacturer, will void any and all stated warranties.

MOUNTING AND WIRING

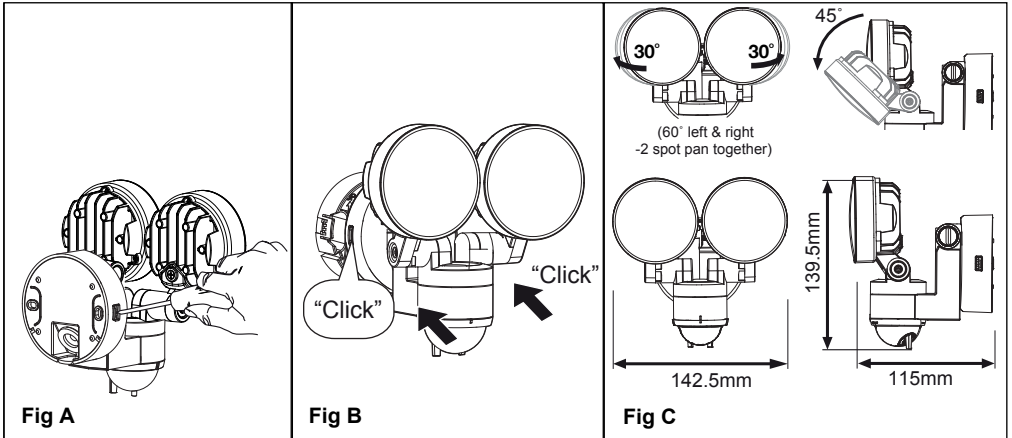
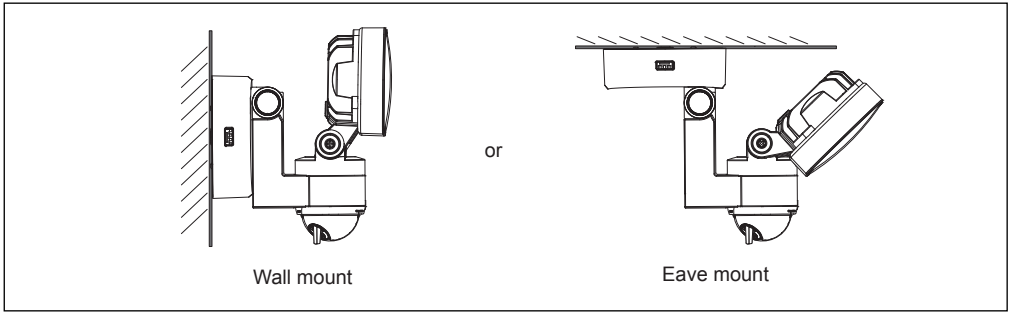

- Switch off the power supply before commencing electrical work.
- Using a flat head screwdriver, carefully lever the side tabs to separate the mounting base from the main housing (Fig A).
- Pierce the power cable entry grommet on the mounting base and slowly draw the power cable through the entry hole. 0.75mm² - 1.5mm² round core cable is recommended.
- Firmly secure the base to the wall or ceiling using the mounting screws provided. Mounting holes located in the base are at 60mm centres.
- Wire the cable to the terminal block, ensuring correct polarity. Failure to do so will result in irreparable lamp and sensor failure. A terminal for an earth parking is provided if required. Relocate the main housing over the base and push together until it 'clicks' into finished position (Fig B).
- Adjust the base pivot to orientate the fitting with the sensor adjusters pointing downwards.
- Tighten thumb screw to secure. Aim spotlight head to suit the locations.

OPERATING ADJUSTMENT

This light fitting only operates when the PIR sensor is activated by heat movement within its detection zone. Once power is connected, the unit requires approx. 60 seconds to warm up. Do not commence any walk tests until this has occurred.

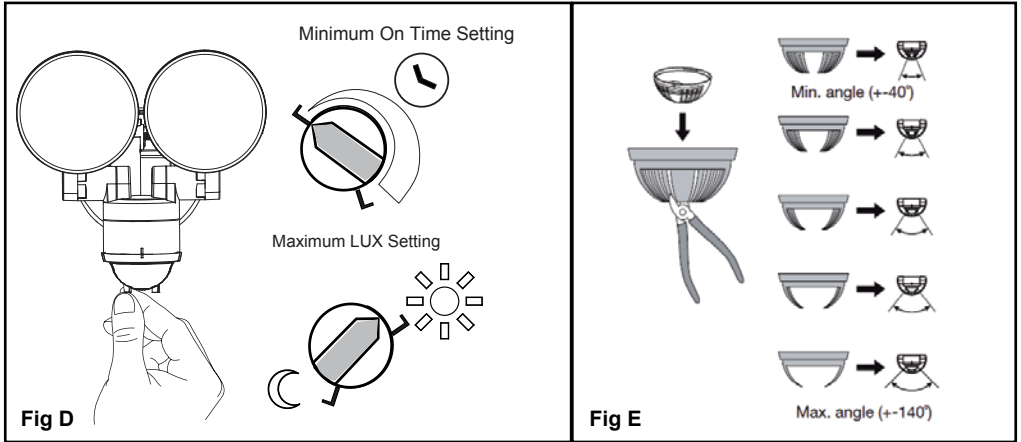

Time

The TIME adjustment has a minimum of approx. 30 seconds (counter clockwise rotation to the end) which it should be set to for walk testing the unit (Fig D). Adjust this setting clockwise to the preferred duration for the light to activate when it detects movement. The maximum clockwise setting will be approx. 6 minutes. The timer will restart each time the sensor detects any new movement.

LUX

The LUX adjustment sets the acceptable amount of light present before the unit will start detecting. Rotating the dial clockwise to the end will set it to full daylight operation. Use this setting for walk testing the unit (Fig D). Fully rotating counter clockwise will set the unit to activate after dark only.

PIR Sensor

The PIR sensor has a 140° detection angle. This detection angle can also be aimed 90° left or right by pivoting the PIR cover where it joins the main housing.

PIR Lens Mask

The PIR lens mask supplied can be used when needed for restricting detection angles of the PIR (Fig E). Removing the largest centre segment provides a 40° detection area, while removing all segments provides maximum 140° angle. The mask clips into place. Remove one segment at a time, aim, and check in walk test mode. Continue removing segments until correct coverage is achieved. The purpose of the lens mask is to block out areas not desired for detection. Apply to PIR lens as required for your location.

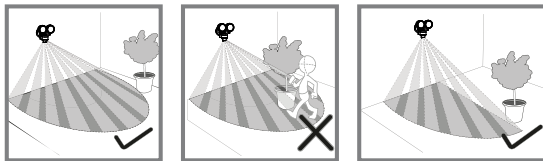

Special Note

Care and consideration should be taken when the unit is located close to property boundaries, to avoid unnecessary spill light or glare to neighbours, and to avoid unwanted activation by passing pedestrians or vehicles.

PRODUCT COMPLIANCES

Product complies with:

AS/NZS60598.1:2003 AS/NZS60598.2.5

EN55015:2006 EN61000.3.2:2000 EN61000.3.3:1995 EN61547:1995

EN62031 EN 62471:2008 EN62471 EN60529 and relevant amendments.

MANUFACTURERS EXTENDED WARRANTY

This product is guaranteed Ventair Pty Ltd for 36 MONTHS from the date of purchase against faulty materials or workmanship which affects its designed ability to detect or switch. During this period if the product has a defect of this nature it will be repaired or replaced free of charge by Ventair with the same item, or a similar one of higher specification. ON CONDITION THAT:

The buyer returns it to the seller from whom it was bought, freight paid.

The product has been bought by the user i.e. a receipt/sales invoice is produced as proof of purchase.

The product has not been misused or handled carelessly, installed in anyway contrary to the installation instructions, or installed in any unusually exposed or harsh environmental conditions.

This guarantee excludes liability for discolouration of paint or plastic, or any user replaceable parts. It does not confer any rights other than those expressly set out above and does not cover any claims for consequential loss or damage.

Our Goods come with guarantees that cannot be excluded under the Australian and New Zealand Consumer Law.

You are entitled to a replacement or refund for a major failure and for compensation for any other reasonably foreseeable loss or damage. You are also entitled to have the Goods repaired or replaced if the Goods fail to be of acceptable quality and the failure does not amount to a major failure.

