

Last modification 2023-10-04

## ORISTA PE-BRS 9329501066119



Featuring a dual-tiered design, the Orista Artisan Brass Pendant Light combines the elegance of leaded glass in the upper tier with the subtle sophistication of acid-frost glass in the lower tier. Handcrafted with precision and encased in a solid brass frame, it harmoniously blends artistry with craftsmanship. This exquisite pendant is a true testament to the marriage of form and function, bringing both aesthetic appeal and ambient lighting to your living spaces. Can be mounted as close to ceiling.

### Overview

|                        |                 |
|------------------------|-----------------|
| <b>Family name</b>     | Orista          |
| <b>Categories</b>      | Pendants        |
| <b>Suspension Type</b> | Chain           |
| <b>Usage</b>           | Indoor Lighting |

### Color / Material

|                          |             |
|--------------------------|-------------|
| <b>Fixture Finish</b>    | Brass       |
| <b>Fixture Material</b>  | Solid Brass |
| <b>Diffuser Material</b> | Glass       |

### Size

|                               |       |
|-------------------------------|-------|
| <b>Fixture Width (cm)</b>     | 50.0  |
| <b>Fixture Height (cm)</b>    | 20.8  |
| <b>Shade Diameter (cm)</b>    | 50.0  |
| <b>Suspension Length (cm)</b> | 200.0 |

### Specification

|                                      |  |
|--------------------------------------|--|
| <b>Voltage Input</b>                 | 240V                                   |
| <b>Total Wattage (max)</b>           | 150                                    |
| <b>Wattage</b>                       | 25                                     |
| <b>Globe Type</b>                    | E27                                    |
| <b>Globe / Light Source qty</b>      | 6                                      |
| <b>Globe / Light Source included</b> | No                                     |
| <b>Dimmable</b>                      | Globe Dependant                        |
| <b>Electrical Protection</b>         | CLASS I - HIGH VOLTAGE, EARTH REQUIRED |
| <b>IP rating</b>                     | IP20                                   |

All representations within this document are subject to copyright. ELECTRICAL INSTALLATIONS MUST BE PERFORMED BY A QUALIFIED ELECTRICAL CONTRACTOR AND INSTALLED IN ACCORDANCE WITH AS/NZS 3000.  
NOTE : All images , descriptions and dimensions are indicative. Please check latest version of item detail on Telbix website prior to ordering or installation.

|                              |  |
|------------------------------|--|
| <b>Lead and Plug</b>         | No   |
| <b>Approvals</b>             | RCM  |
| <b>Installation Required</b> | Yes (by Licensed Electrician only)                             |
| <b>Care Instructions</b>     | Do not use strong liquid cleaners, Wipe clean with a dry cloth |
| <b>Replacement Warranty</b>  | *3 Years   |

Barcode

**GTIN** 9329501066119

Image -dimensions

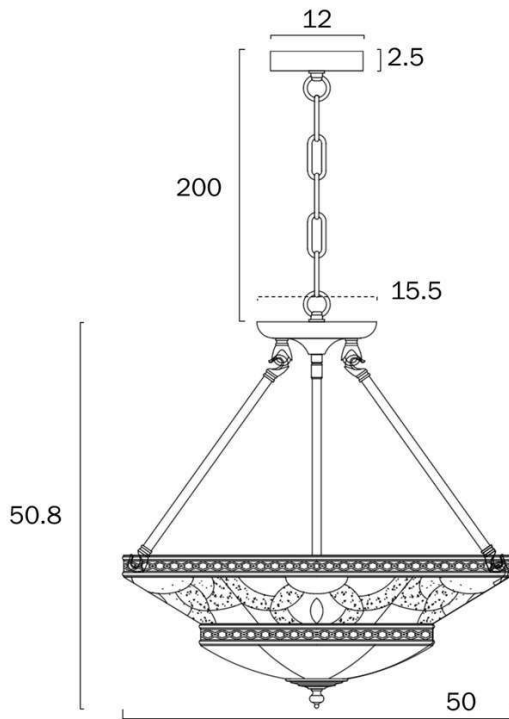

Note: Dimensions are only a guide and may vary due to manufacturing variations.

