

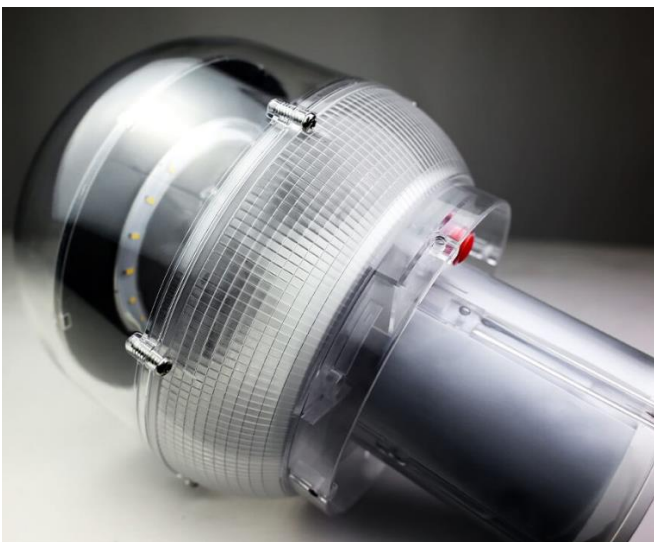

Commercial Solar Bollard Light 130

The Commercial Solar Bollard Light 130 is a high quality, durable bollard light suitable for many commercial and residential situations. This light features a sunlight-tracking solar panel which optimises solar absorption by 20-30% to efficiently recharge the battery. Its high-performance lithium-ion battery can provide over 7 nights of continual lighting per charge.

- ✓ Easy installation.
- ✓ 3 lighting modes.
- ✓ 5-year product warranty (battery included).
- ✓ 7+ nights of continual lighting per charge.
- ✓ Rotating sunlight tracking solar panel.
- ✓ Durable, sturdy design.
- ✓ IP66 water and dust proof rating.
- ✓ IK10 degree of protection.



Commercial Solar Bollard Light 130

Applications:

- Paths/walkways
- Driveways
- Jetties
- Marinas
- Pontoons
- Gardens
- Parks

Lighting modes:

RED: 300 lumens for the first 5 hours after dusk then 100 lumens until dawn.

YELLOW: 100 lumens all night until dawn.

GREEN: 200 lumens all night until dawn.

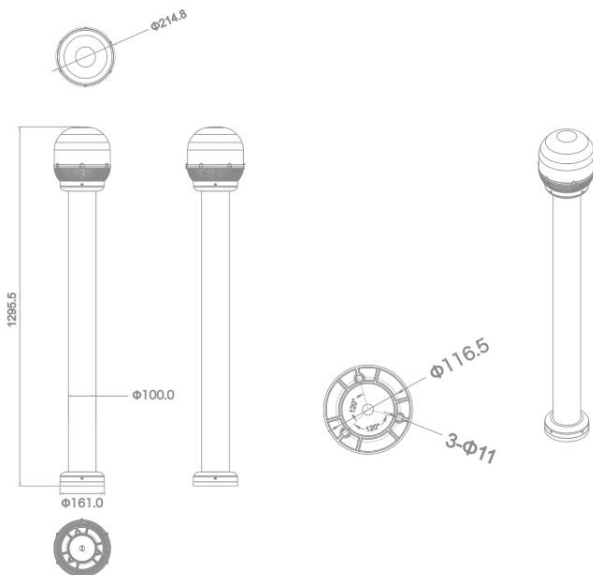

CBL-3

Lumens output	300 lumens 230lm/w
Solar panels	4.3V/2.8W Monocrystalline silicon
Battery	Li-ion 3.7V 10AH
Solar charging time	15 hours (by direct sunlight)
Charge life	7+ nights
Material	Light globe - Polycarbonate, Light base - Powder coated Aluminium Alloy Anti- corrosion C4H
IP rating	IP66

IK rating	IK10
Dimensions	129.5 x 21.4cm
Installation distance	5-15 m depending on site requirements
Weight	5.76kg
LED colour temp	4000K
Lighting area (m2)	150m2

