

# Commercial Range

## Wall Washers/Uplighters

### In-Ground Uplighter

Product Code	LED's	Battery	Solar Panel	IP Rating	Lumens
SLDIG-2W	2 x Epistar 5050 LEDs @ 1Wea (Warm White)	1 x 12V 2Ah Lithium	6V Integrated Polycrystalline	65	180 @ 1m

#### Features:

- Built in Photo Electric Cell
- Stainless Steel Construction
- Approximately 4-6 hours Operation
- Max Walk Over Pressure - 100kg
- Flush Mounting Position
- Tempered Glass
- Depth:
  - o Without Recessing Frame = 65mm
  - o With Recessing Frame = 90mm

**2 Year Warranty!**

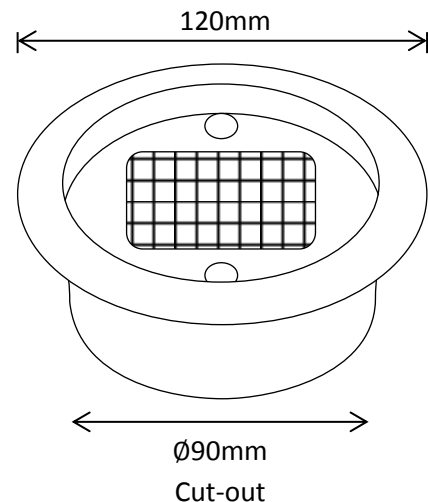

#### Packaged Fitting Weight & Dimensions

W: 0.7kg

D: 12.5cm x 12.5cm x 12cm