

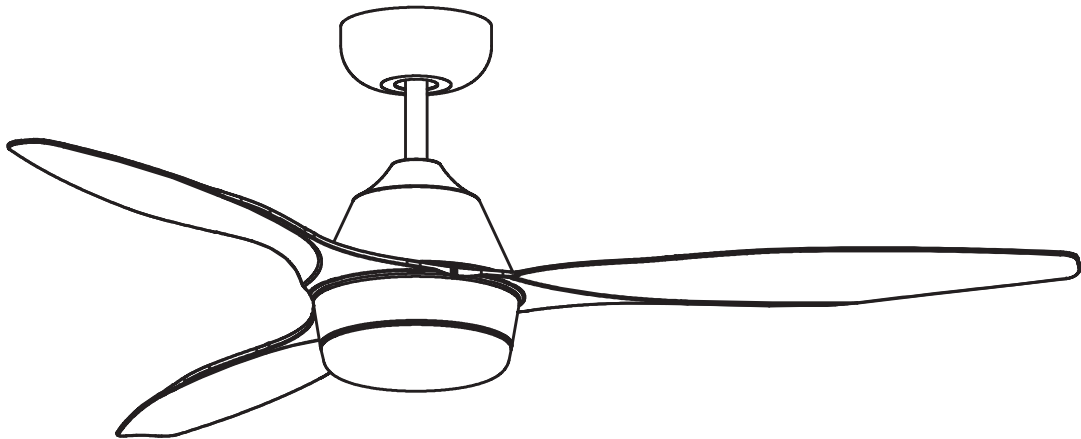

Triumph

Series

Ceiling Fan Instruction Book



Models: MTF133 MTF1333

Contents List:

DESCRIPTION	QUANTITY
Motor assembly	1
Instruction manual	1
Screw kit	1
Balancing kit	1
Hanging bracket	1
Wall control kit	1
Blade	3
Cover	1
Light plate	1 (for with light)
Glass shade	1 (for with light)

This appliance is not intended for use by persons (including children) with reduced physical, sensory or mental capabilities, or lack of experience and knowledge, unless they have been given supervision or instruction concerning use of the appliance by a person responsible for their safety.

Children should be supervised to ensure that they do not play with the appliance.

Means for disconnection must be incorporated in the fixed wiring in accordance with the wiring rules.

The blades are more than 2,1 m above the floor.

Thank you for purchasing your MARTEC Imperial Series product. Please read all instructions carefully before assembly and use.

IMPORTANT SAFEGUARDS

READ THESE INSTRUCTIONS CAREFULLY BEFORE INSTALLING OR USING THE PRODUCT. KEEP THE INSTRUCTIONS HANDY FOR FUTURE REFERENCE.

IMPORTANT: Always operate the product from a power source of the same Voltage, Frequency and rating as on the product Identification Plate.

IMPORTANT: The fan is to be installed so that the blades are more than 2.1 metres above the floor.

Avoid contacting moving parts, keep hands, hair and clothing well away from the product while it is in operation.

A Luminaire (light fitting) included in the fan packaging may only be fitted to this fan.

“This appliance is not intended for use by persons (including children) with reduced physical, sensory or mental capabilities, or lack of experience or knowledge, unless they have been given supervision or instruction concerning use of the appliance by a person responsible for their safety.”

“Young children should be supervised at all times to ensure that they do not play with the appliance.”

Do not operate any product which has been or appears damaged in any manner or after the product malfunctions.

CAUTION: To reduce the risk of electric shock, do not install the product where it can be exposed to rain, moisture or any liquid.

Do not use the product for other than its intended use as described in these instructions. This product is intended for normal domestic household use only. The use of accessory attachments other than those recommended by the manufacturer may cause safety hazards.

SAFETY

Installation of fans must follow S.A.A. standards and meet local Authority regulations. A fully qualified and licensed electrician lawfully MUST carry out installation. Means for disconnection must be incorporated in the fixed wiring in accordance with wiring rules.

Fan and light MUST be earthed. Bracket MUST be firmly attached to a solid structure i.e. concrete ceiling, steel structure or timber frame, etc. and MUST be nailed between beams if the timber option is required. ONLY install the remote controller kit that comes supplied by Martec Pty Ltd within package. DO NOT control operation of fan and light with any other remote control than what was approved by Martec Pty Ltd and supplied within this package, as this will void warranty.

WARNING

Only approved Martec Pty Ltd wall controllers should be used for the operation of our fans. The use of unauthorised controllers will void the warranty. DO NOT mix blades from one fan to another. All blades must be replaced if damaged.



Hanging plate



Canopy

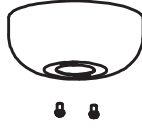

Hanging ball

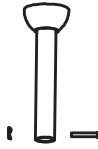

Down rod



Cover



Wall control

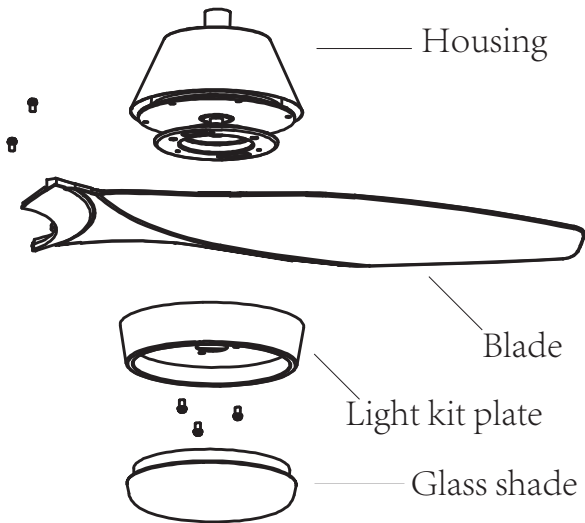

With light

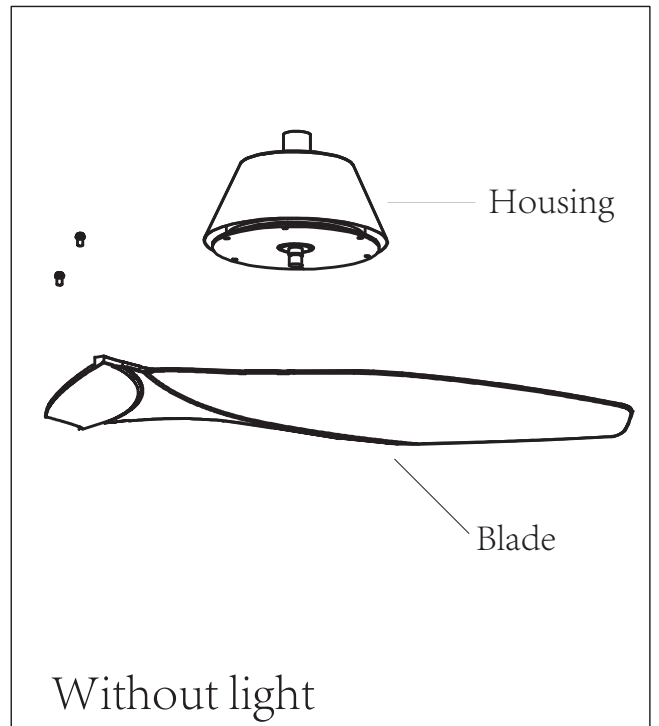

Without light

Hardware packs

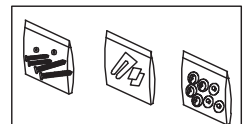

HOW TO INSTALL THE LIGHT KIT PLATE (Version with light/Version with light)

Fan blade installation (See Fig.1.1 Fig.1.2 Fig.1.3 Fig.1.4 Fig.1.5 Fig.1.6)

HOW TO ASSEMBLE

Unscrew the top cover screw. (See Fig.1.1)

Pull out the top cover. (See Fig.1.2)

Installation blade. (See Fig 1.3)

Install upper cover. (See Fig 1.4)

Lock screws. (See Fig 1.5)

Installation Hanging ball Down rod. (See Fig 1.6)

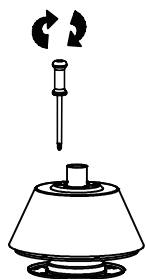

Fig. 1.1

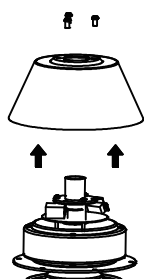

Fig. 1.2

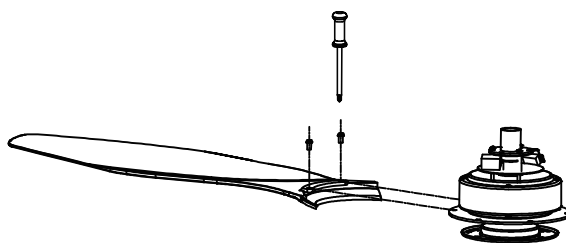

Fig. 1.3

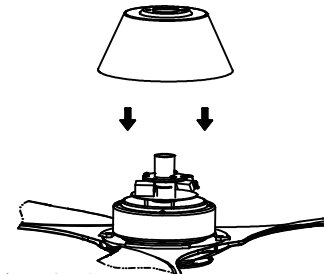

Fig. 1.4

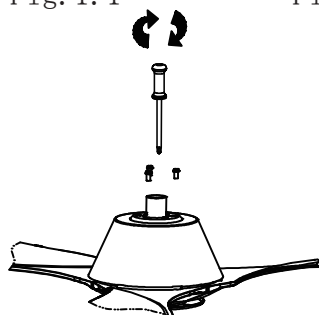

Fig. 1.5

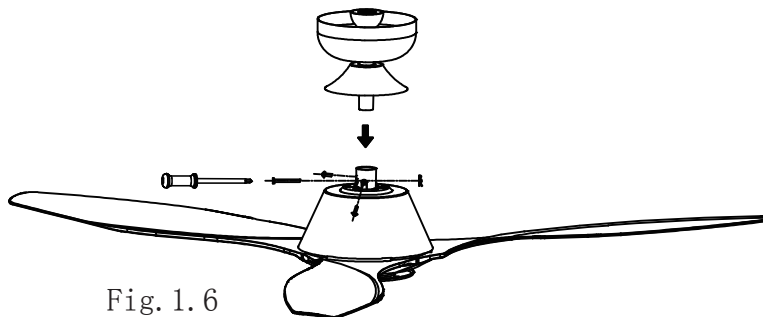

Fig. 1.6

HOW TO ASSEMBLE

Secure the hanger bracket to ceiling beam or a suitable piece of timber inserted between the ceiling beams. Martec Pty Ltd recommends the bracket to be attached with two long screws as supplied within the package. There is a ball seat rubber cover need to be pressed into the bracket. (See Fig.2)

Place circular shockproof gasket above the hanger bracket. Align the rabbit and lock the hanger bracket to the ceiling tightly. (See Fig.3)

Place fan into hanger bracket and align Ball Joint Slot with hanger bracket as illustrated. (See Fig.4)

After wiring is completed, attach the canopy to the hanger bracket by pushing upwards and twisting anti-clockwise. Locate screws in keyholes and tighten, ensuring canopy is not touching the ball joint. (See Fig.5)

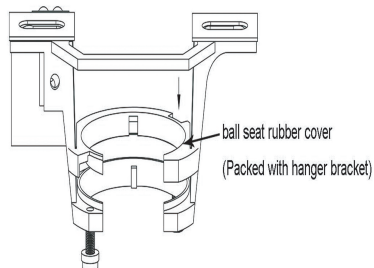

Fig. 2

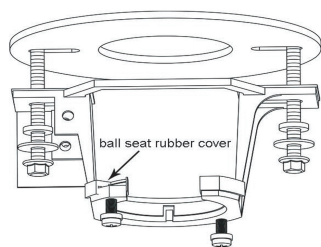

Fig. 3

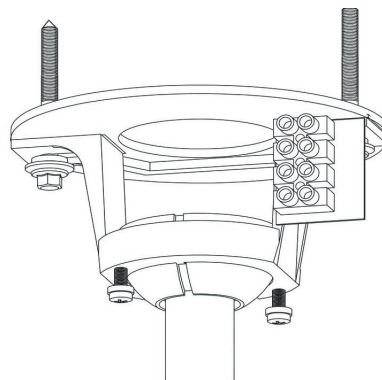

Fig. 4

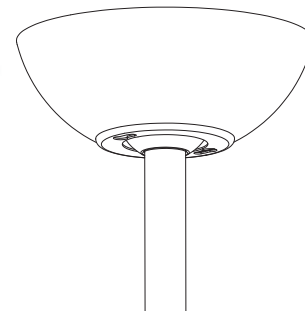

Fig. 5



HOW TO INSTALL BLADES

Install lamp panel (When there is a lamp installed in this way.)

(See Fig. 6)

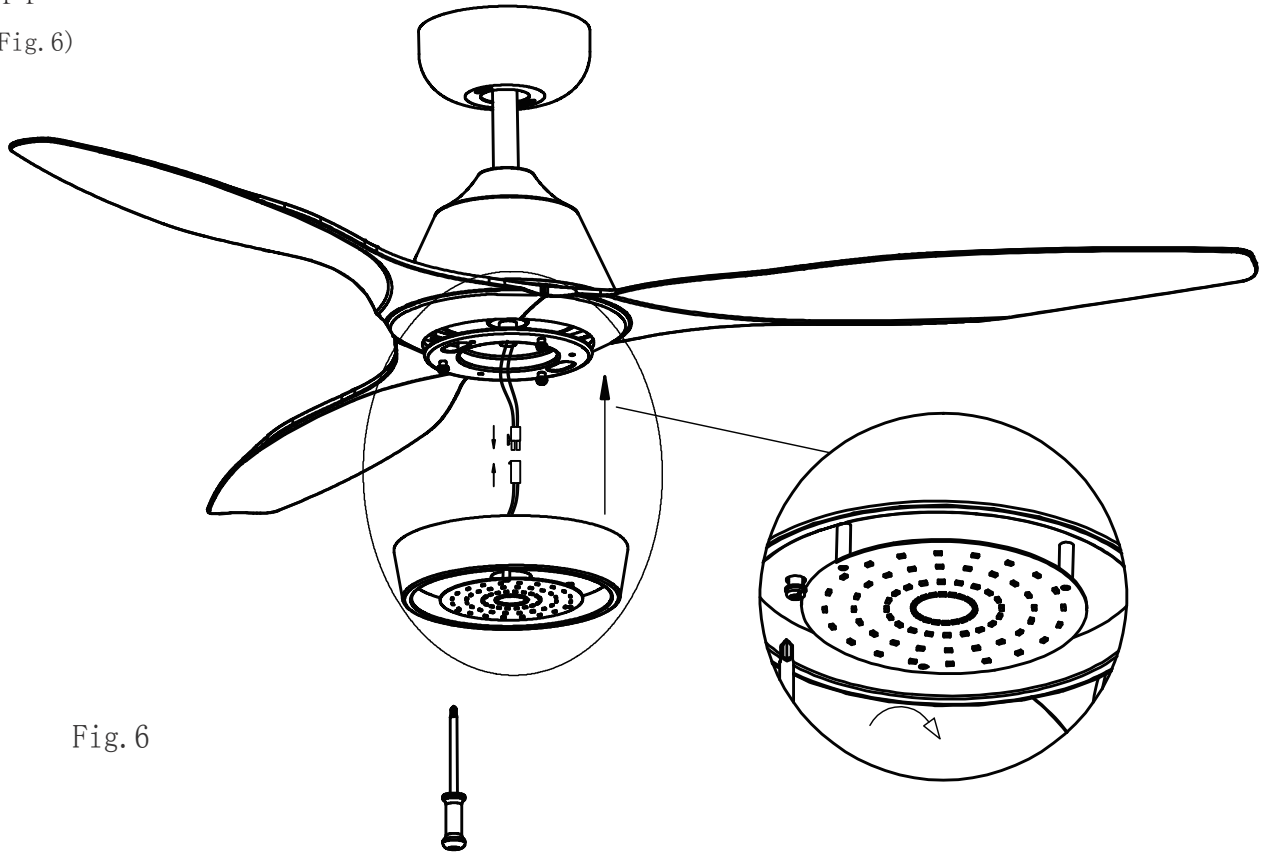

HOW TO INSTALL THE FACE PLATE (Version with light)

Install the lamp shade

(See Fig. 7)

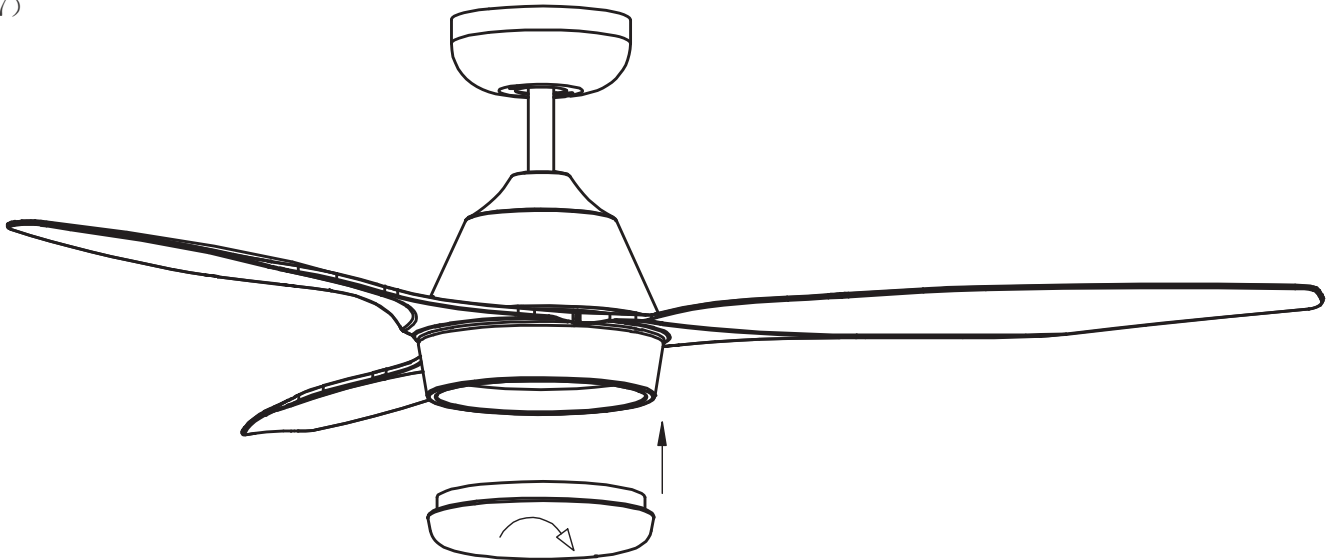

CCT (Colour changeable temperature)

Please make sure the switch is off before changing the colour temperature. Simply flick LED plate (See Fig. 8.) to select the desired colour temperature (3000K, 4000K or 5000K).



Fig. 8

Dimming

The Imperial fan has a smart 3 step dimming LED light module which doesn't require a dimmable remote control or a wall dimmer. It only requires a normal on/off remote kit (MPREM) or a normal light wall switch (supplied as part of the wall controller in the box).

Turn the switch on and the light will turn on. Flick the switch on/off within 1 second and the light output will dim down to approx. 50%, flick the switch on/off again and the light output will down to approximately 15%. The light kit has no memory function, it will turn on at 100% initially.



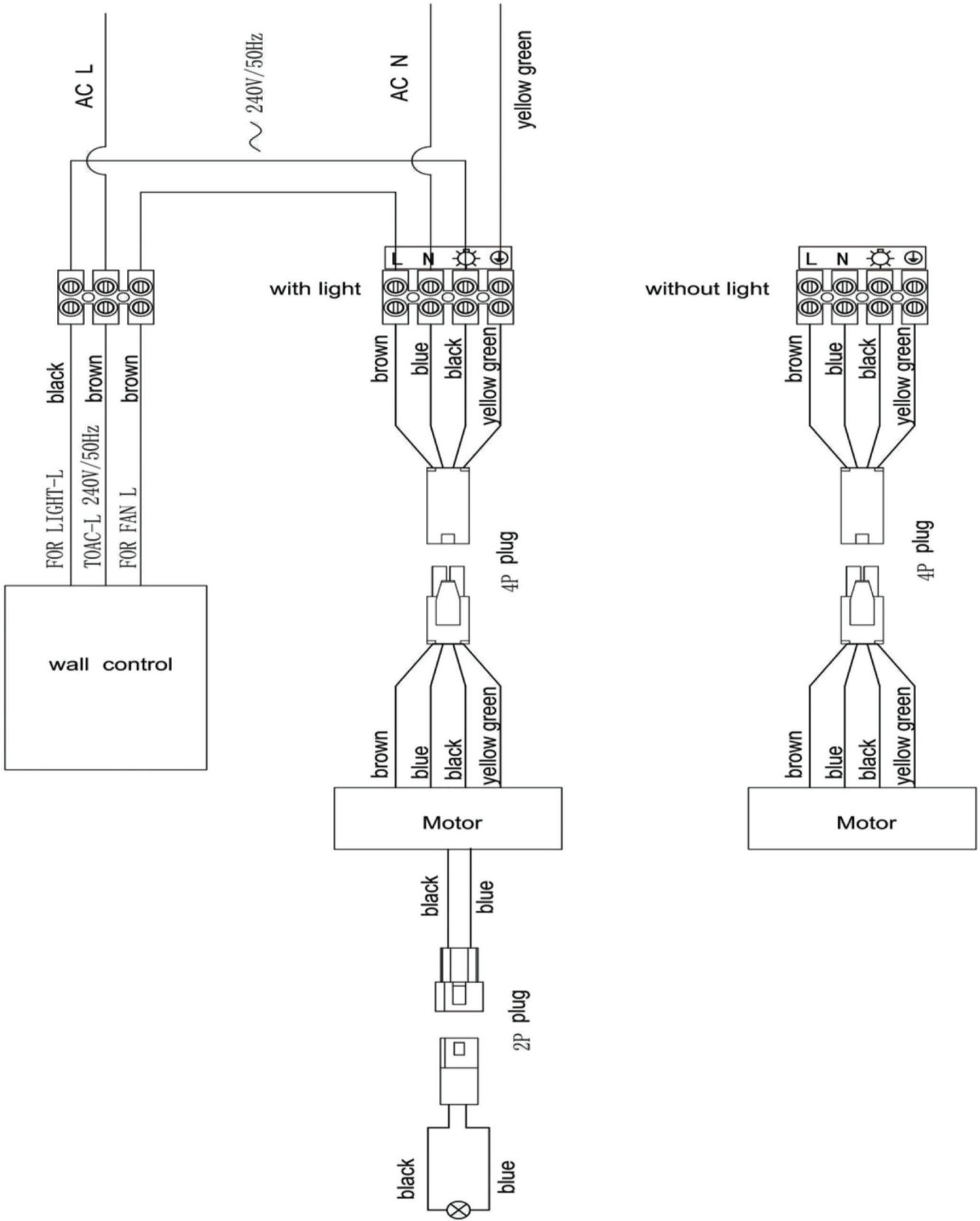

MARTEC PTY LTD: 3 YEAR IN HOME WARRANTY STATEMENT*

*Martec Pty Ltd warrants this product for a period of 3 years "In Home" warranty from the original date of purchase for residential situations, subject to the following statements:

Important notice: Martec Pty Ltd warrants this product for 3 years with "In Home" warranty. Martec Pty Ltd only warrants the Martec product against faulty workmanship and subject to the conditions and provisions set out below:

- 1) The 3 year "In Home" warranty applies only if the product was purchased in Australia and does not transfer from the original purchaser. All Martec Products replaced under warranty are only warranted for the balance of the warranty period.
- 2) The 3 year "In Home" warranty does not extend to the Martec Product accessories such as remote controller kits and/or light fittings (including glass light shades) that have been fitted during or after the original Martec Product installation. Globes are not covered under warranty.
- 3) All remote controllers, wall controllers, ballasts, and light fittings included in the Martec Products original packaging have a 1 year warranty only. Remote controllers, wall controllers and light kits must be Martec approved and Martec branded products. The use of remote controllers, wall controllers and/or light kits which are not Martec approved and branded will subsequently void the warranty.
- 4) Any changes to plated and/or painted finishes due to climate conditions or other circumstances deemed to be beyond the control of Martec Pty Ltd or their authorised agent are not covered under this warranty. Outdoor use of Martec ceiling fans is not recommended or covered under this warranty; proceed at your own risk as outdoor use will void the warranty.
- 5) Threaded components such as blade nuts and screws may loosen during normal operation; these should be tightened regularly to ensure the fan does not develop noises during operation. If noises do develop, check this aspect before requesting service, as this is not covered under warranty.

PURCHASERS PLEASE NOTE:

- 6) Any claim made in relation to this warranty is solely limited to the cost of replacement of the product, parts and labour of the authorised service agent approved by Martec Pty Ltd. No parts/products are to be disposed of prior to the Service Agents "In Home" warranty visit. No acceptance of other liability for incidental or consequential damage is covered. Martec Pty Ltd does not cover travelling costs incurred by service agents where service is requested by the purchaser outside of the Martec Pty Ltd service network. The Martec Pty Ltd service network is defined at our discretion, yet is limited by the boundary of the city in which you live. Travel outside of the city limits by the Martec Pty Ltd authorised service agent will incur commercial costs to be paid for by the purchaser at a rate calculated by the number of kilometres travelled beyond the city limits. Any service required outside of the service network will be provided in the following manner.
Per warranty claim, a full replacement will be sent to the customer's residence and a maximum of \$80AUD plus GST plus freight will be covered by Martec Pty Ltd. All other costs over and above the \$80AUD, including but not limited to, labour and travel costs are to be paid for by the purchaser. Please Note: it is the responsibility of the purchaser to call Martec customer service number (1300 730 064 or 02 8778 7500) prior to any electrician leaving the job site if any problems occur. Any installing electrician costs and/or fees invoiced to the customer prior to the customer contacting Martec to lodge a warranty application will not be covered by Martec.
- 7) This warranty becomes void if the product was not installed as per the instruction manual by a qualified and licensed electrician. In addition, this warranty will be considered void if any, or all, of the following has occurred: tampering with the product, product damage, repair by non-qualified electrician, becoming faulty due to improper use, normal wear and tear, accident damage, product abuse, and/or failure to use the product in accordance with the instructions relating to the installation.
- 8) This product is only covered by this warranty for a period of 90 days when used in a commercial application.
- 9) Minor variations of speed between the same model Martec Products may be evident and is not covered under this warranty. Any changes in climate conditions deemed by Martec Pty Ltd to be beyond reasonable control are not covered under this warranty. Any damage caused to walls, ceilings, furniture, carpet and/or any consequential damage caused within the establishment where this Martec Product is being installed, is not covered under this warranty.
- 10) Repairs carried out by the Martec approved service agent due to incorrect installation will be charged to the purchaser at the time of service. This warranty is limited to the product being repaired/replaced only by an approved Martec Pty Ltd service agent and does not include costs where the original installation was not carried out per the instruction manual. The product warranty is limited to defects in workmanship only and does not apply to loss or damage caused by abnormal or excessive force of any kind from internal or external sources.
- 11) This warranty does not cover electrical humming noises, wobbling or any other external influences.
- 12) Martec Pty Ltd reserves the right to change or amend any or all parts of this warranty statement at any time and without notice.
- 13) The costs associated with the hire of extension ladders and scaffolding to service ceiling fans installed on ceilings higher than 3 metres from the ground, will not be covered by this warranty. These costs will be borne by the customer not Martec Pty Ltd.



BE ADVISED: All ceiling fans will emit some audible noise; and said noise will be most apparent at night or during period of time when there is less ambient noise to interfere with said noise, and especially on low speed settings, slight electrical fluctuations will cause said noise. This noise is referred to as ripple control, which is a method used by electricity companies to control utilities by using a superimposed frequency on your standard 50Hz AC power supply. Typically, the ripple control is used to control and manage peak power loads on electrical distribution networks. The noise is the result of the electricity supplier alternating the direct current entering your house in order to check if, for example, street lights are operational. This may cause intermittent humming noises in the ceiling fan and is not covered under warranty. A light fitting will often accentuate noises and vibrations, which can be traced to loose glass fittings or other components; this is not covered under warranty. To learn more about ripple control, please visit our website at: <http://www.martecceilingfans.com.au>

NOTE: Martec Pty Ltd assumes that installation of said Martec Product is carried out as this instruction manual has aforementioned. It is the purchaser's responsibility to ensure that the installation of said Martec Product has been carried out by a certified electrician as per the guidelines of this instruction manual. As it is the purchaser's responsibility to check the stability and proper installation of the Martec Product, the purchaser's electrician should check and identify any problems prior to finalising installation. Steel beams, grid ceilings and flexible surfaces will not absorb vibration and may cause some audible noise due to vibration; as a result this will not be considered a fault and will not be covered under this warranty.

Martec Pty Ltd only covers manufacturing faults associated with said Martec Product per the above warranty provisions. The warranty will not cover the entry of foreign matter or influences to the product including, but not limited to: liquid, moisture, dirt, dust, electrical fluctuations, or any additional problems encountered if a Martec ceiling fan is used in an outdoor environment. Power supply faults or influences resulting in damage to this product are not covered under this warranty. The warranty does not cover any loss, damage or delay directly or indirectly caused by any malfunction of or defect of or failure of the product other than stated in this warranty.

NOTE: Stainless steel requires regular cleaning; "Tea Staining" is a common occurrence with all types of stainless steel. This is not considered a fault of the product and is not covered under warranty. Martec's Precision 316, while made from Marine Grade 316 stainless steel, should only be used in a covered or enclosed outdoor environment as the fan is not hermetically sealed and will eventually rust internally. With the exception of the Precision Stainless Steel 316 ceiling fan, none of Martec's Ceiling Fans are meant for outdoor use, and will either rust or encounter problems which are not covered within this warranty.

IMPORTANT NOTICE: All claims for warranty must be accompanied with the following three documents:

- 1) Copy of the Installation Receipt OR Tax Invoice OR Certificate Of Compliance for the installation of the Martec product from the installing electrician. If one of these installation documents cannot be provided, we will only accept a typed and signed letter on a business letterhead from the installing electrician stating he/she installed the Martec product at your address along with a scanned copy of the electrician's licence. Please note that an email is not a sufficient installation document.
- 2) Copy of the Purchase Receipt/store Tax Invoice for the Martec Ceiling Fan.
- 3) Copy of the completed warranty card, signed and dated. The warranty card is located after this warranty statement, or on the last page of your instruction manual. Please ensure that the purchaser's full name and contact details are clearly stated, in addition to the full nature of the fault and the serial or P.O. number which can be located on the top motor housing above the Ceiling Fan Blades.
Upon receipt of the abovementioned documentation, Martec Pty Ltd will issue a service call to fulfil the conditions of this warranty. It is the responsibility of the purchaser to keep the documents required for a warranty application for the duration of the "In Home" warranty period.

Upon receipt of the abovementioned documentation, Martec Pty Ltd will issue a service call to fulfil the conditions of this warranty. It is the responsibility of the purchaser to keep the documents required for a warranty application for the duration of the "In Home" warranty period.

Customer Service operates between 9AM to 5PM EST Monday through Friday

Customer Service Local Number: 02 8778 7500 Customer Service Fax: 02 8778 7555

IMPORTANT: Please do not phone the retailer for warranty work. Instead phone the Customer Service Hotline found above.

Martec Pty Ltd | 6 Austool Pl, Ingleburn NSW 2565 | Ph: 02 8778 7500 | Fax: 02 8778 7555



Customer Details

Surname..... Given Name.....

Address.....

Daytime Ph..... A/h Ph.....

Email.....

Warranty Details

Date of Purchase..... Installation Date.....

Product Description.....

Store..... P.O. No.....

Fault Description.....

.....

.....

.....

I, the Customer, hereby acknowledge that I have read and agree with the Martec Pty Ltd warranty statement and the conditions found within regarding the warranty service and its limitations.

I, the Customer, acknowledge that Martec Pty Ltd reserves the right to charge me, the Customer, \$80 plus GST plus the costs of any replacement parts or products (if any), in addition to the costs associated with shipping these parts to my location should the reported fault not be an actual manufacturing fault or malfunction. This will be assessed on a case by case basis by the authorised Martec Service Agent dispatched to my premises.

I, the Customer, acknowledge that I will be liable for this charge should the authorised Martec Service Agent determine this to be the case. Failure to pay warranty recovery charges issued by Martec Pty Ltd will result in the termination of any remaining warranty, in addition to possible debt collection procedures.

I,, do hereby certify that I have read and comply with the aforementioned warranty conditions and agree to the conditions of this warranty claim.

Print Name:.....

Signature:.....

Date:.....