

# 30w 24v DC Dali Dimmable Weatherproof LED Driver



PRODUCT SPECIFICATIONS	
MATERIAL	Aluminium
COLOUR/FINISH	Blue
WORKING TEMPERATURE	-40C to +60°C
OVERLOAD PROTECTION	Yes
SHORT CIRCUIT PROTECTION	Yes
OVER VOLTAGE PROTECTION	Yes
DIMMING	Dali Dimmable
INPUT VOLTAGE	240v AC (Supplied with flex & plug)
OUTPUT VOLTAGE	24v DC Constant Voltage
RECOMMENDED MAX. LOAD	24w
IP RATING	IP66
WARRANTY	5 Years Replacement



TECHNICAL SPECIFICATIONS		
PART NUMBER:		HCP-52223
OUTPUT	DC Voltage	24V
	Voltage Tolerance	±0.5V
	Voltage Regulation	± 0.5%
	Rated current	1.25A
	Rated power	30W (Recommended Maximum Load = 24w)
	Load Regulation	± 1.5%
INPUT	Voltage Range	200-240VAC
	Frequency Range	47 - 63Hz
	Power Factor(Typ.)@ full load	PF≥0.97/230VAC
	THD(Typ. ) @ full load	< 20%
	Efficiency(Typ.)@ full load	80%
	AC Current(Max.)	0.25A
	Inrush Current (Typ.)	30A,50%,90us
	Leakage current	<0.5mA
PROTECTION	Short Circuit	Shut down o/p voltage, re-power on to recover after fault condition is removed
	Over Load	≤120% shut down o/p voltage, re-power on to recover after fault condition is removed
	Over temperature	100°C±10°C
	Protection Class	II
ENVIRONMENT	Working TEMP.	-40-+60°C
	Working Humidity	20 - 95%RH,non-condensing
	Storage TEM.,Humidity	-40 - +80°C,10 - 95%RH
	TEMP.coefficient	±0.03%/°C(0 - 50°C)
	Vibration	10~500Hz, 5G 10min./1 cycle,period for 60min. each along X,Y,Z axes
SAFETY & EMC	Safety standards	EN61347-1 EN61347-2-13 EN62493 IP66
	Withstand voltage	I/P-O/P:3.75KVAC I/P-FG:1.88KVAC O/P-FG:0.5KVAC
	Isolation resistance	I/P-O/P I/P-FG O/P-FG: 100MΩ/500VDC/25°C/70%RH
	EMC Emission	EN55015 EN61000-3-2 EN61000-3-3
	EMC Immunity	EN61000-4-2,3,4,5,6,11 EN61547
OTHERS	Net Weight	0.35Kg
	Dimension	260*32*20mm(L*W*H)
	Warranty	5 Years Replacement

# 60w 24v DC Dali Dimmable Weatherproof LED Driver



## PRODUCT SPECIFICATIONS

MATERIAL	Aluminium
COLOUR/FINISH	Blue
WORKING TEMPERATURE	-40C to +60°C
OVERLOAD PROTECTION	Yes
SHORT CIRCUIT PROTECTION	Yes
OVER VOLTAGE PROTECTION	Yes
DIMMING	Dali Dimmable
INPUT VOLTAGE	240v AC (Supplied with flex & plug)
OUTPUT VOLTAGE	24v DC Constant Voltage
RECOMMENDED MAX. LOAD	48w
IP RATING	IP66
WARRANTY	5 Years Replacement

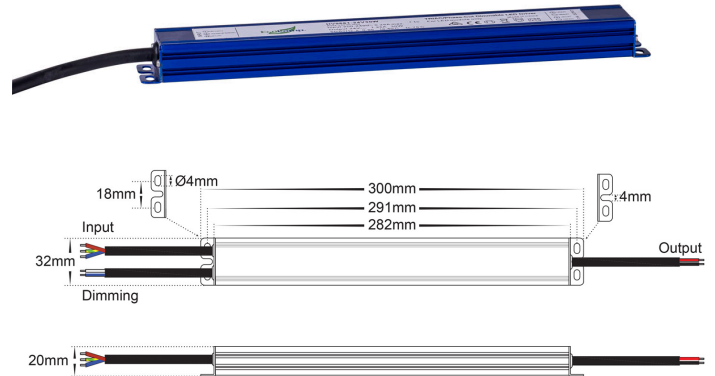

## TECHNICAL SPECIFICATIONS

<b>PART NUMBER:</b>		<b>HCP-52233</b>
<b>OUTPUT</b>	DC Voltage	24V
	Voltage Tolerance	±0.5V
	Voltage Regulation	±0.5%
	Rated current	2.5A
	Rated power	60W (Recommended Maximum Load = 48w)
	Load Regulation	±1.5 %
<b>INPUT</b>	Voltage Range	200-240VAC
	Frequency Range	47 - 63Hz
	Power Factor(Typ.)@ full load	PF≥0.97/230VAC
	THD(Typ. ) @ full load	<20%
	Efficiency(Typ.)@ full load	85%
	AC Current(Max.)	0.5A
	Inrush Current (Typ.)	50A,50%,176us
	Leakage current	<0.5mA
<b>PROTECTION</b>	Short Circuit	shut down o/p voltage, re-power on to recover after fault condition is removed
	Over Load	≤120% Hiccup mode,recovers automatically after fault condition is removed
	Over temperature	100°C±10°C
	Protection Class	II
<b>ENVIRONMENT</b>	Working TEMP.	-40-+60°C
	Working Humidity	20 - 95% RH,non-condensing
	Storage TEM.,Humidity	-40 - +80°C, 10 - 95%RH
	TEMP.coefficient	±0.03%/°C(0 - 50°C)
	Vibration	10~500Hz, 5G 10min./1 cycle,period for 60min. each along X,Y,Z axes
<b>SAFETY &amp; EMC</b>	Safety standards	EN61347-1 EN61347-2-13 EN62493 IP66
	Withstand voltage	I/P-O/P:3.75KVAC I/P-FG:1.88KVAC O/P-FG:0.5KVAC
	Isolation resistance	I/P-O/P I/P-FG O/P-FG: 100MΩ/500VDC/25°C/70%RH
	EMC Emission	EN55015 EN61000-3-2 EN61000-3-3
	EMC Immunity	EN61000-4-2,3,4,5,6,11 EN61547
<b>OTHERS</b>	Net Weight	0.4Kg
	Dimension	300*32*20mm(L*W*H)
	Warranty	5 years replacement

# 100w 24v DC Dali Dimmable Weatherproof LED Driver



PRODUCT SPECIFICATIONS	
MATERIAL	Aluminium
COLOUR/FINISH	Blue
WORKING TEMPERATURE	-40C to +60°C
OVERLOAD PROTECTION	Yes
SHORT CIRCUIT PROTECTION	Yes
OVER VOLTAGE PROTECTION	Yes
DIMMING	Dali Dimmable
INPUT VOLTAGE	240v AC (Supplied with flex & plug)
OUTPUT VOLTAGE	24v DC Constant Voltage
RECOMMENDED MAX. LOAD	80w
IP RATING	IP66
WARRANTY	5 Years Replacement

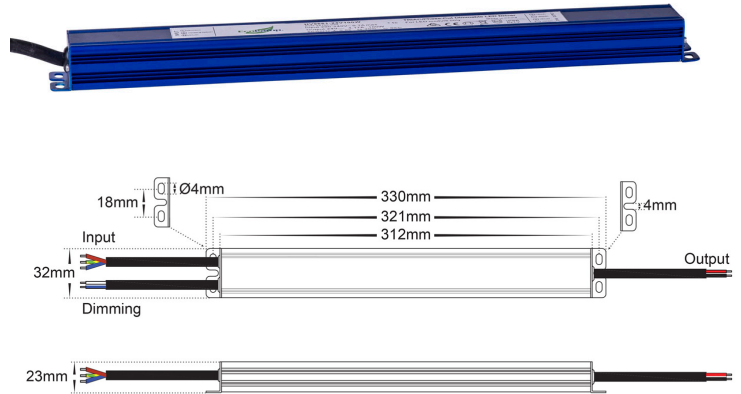

TECHNICAL SPECIFICATIONS		
<b>PART NUMBER:</b>		<b>HCP-52243</b>
<b>OUTPUT</b>	DC Voltage	24V
	Voltage Tolerance	±0.5V
	Voltage Regulation	± 0.5%
	Rated current	4.17A
	Rated power	100W (Recommended Maximum Load = 80w)
	Load Regulation	± 1%
<b>INPUT</b>	Voltage Range	200-240VA
	Frequency Range	47 - 63Hz
	Power Factor(Typ.)@ full load	PF≥0.97/230VAC
	THD(Typ. ) @ full load	< 20%
	Efficiency(Typ.)@ full load	83%
	AC Current(Max.)	0.8A
	Inrush Current (Typ.)	49.5A,50%,490us
	Leakage current	<0.5mA
<b>PROTECTION</b>	Short Circuit	shut down o/p voltage, re-power on to recover after fault condition is removed
	Over Load/ Over temperature	≤120% constant current limiting, recover automatically after fault condition is removed 100°C±10°C
	Protection Class	II
<b>ENVIRONMENT</b>	Working TEMP.	-40-+60°C
	Working Humidity	20 - 95%RH,non-condensing
	Storage TEM.,Humidity	-40 - +80°C,10 - 95%RH
	TEMP.coefficient	±0.03%/°C(0 - 50°C)
	Vibration	10~500Hz, 5G 10min./1 cycle,period for 60min. each along X,Y,Z axes
<b>SAFETY &amp; EMC</b>	Safety standards	EN61347-1 EN61347-2-13 EN62493 IP66
	Withstand voltage	I/P-O/P:3.75KVAC I/P-FG:1.88KVAC O/P-FG:0.5KVAC
	Isolation resistance	I/P-O/P I/P-FG O/P-FG: 100MΩ/500VDC/25°C/70%RH
	EMC Emission	EN55015 EN61000-3-2 EN61000-3-3
	EMC Immunity	EN61000-4-2,3,4,5,6,11 EN61547
<b>OTHERS</b>	Net Weight	0.55Kg
	Dimension	330*32*23mm(L*W*H)
	Warranty	5 Years Replacement