

CC Series Standard – CCS564

Location

Project

Designation

Notes



Features

The Compact Cooler Standard Series of portable fans increases working efficiency by delivering large volumes of cooling air across people in hot working areas. Working efficiency and personal safety are both enhanced when the working area is kept cool. Products can also be cooled more quickly and efficiently when using the Compact Cooler fans. 'Standard' version provides fixed airflow direction.

Construction

Fan is of galvanised steel with a high quality polyester epoxy finish as standard.
Intake and discharge guards are fitted as standard.

Motors

Type - squirrel cage induction motor.
Electrical supply - 240V, single phase, 50 Hz.
- 415V, 3 phase, 50 Hz available on application.
Bearings - sealed for life, ball.
Weatherproof to IP 55.
Operating temperature range -20°C to + 70°C.

Internal Thermal Protection

Replacable fuse fitted as standard.

Special Features

'Standard' version provides fixed airflow direction.
Built-in wheels and handle make it easy to move across even the roughest floors.
Compact slim line design permits operation and storage where space is limited.
Designed to pass through a standard doorway.
Safety guards comply with AS4024.1:1996.
Efficient aerofoil axial impeller.



Technical Data - CCS564

Speed [rps]	Avg. dBA @ 3m	kWatts (Input)	Amps	Max.° C	Approx. Weight [kg]
22	58	0.75	4.9	40	26

CC Series Standard – CCS564

Suggested Specification

The Compact Cooler Series of portable cooling fans shall be as designed and manufactured by Fantech Pty Ltd.

Dimensions

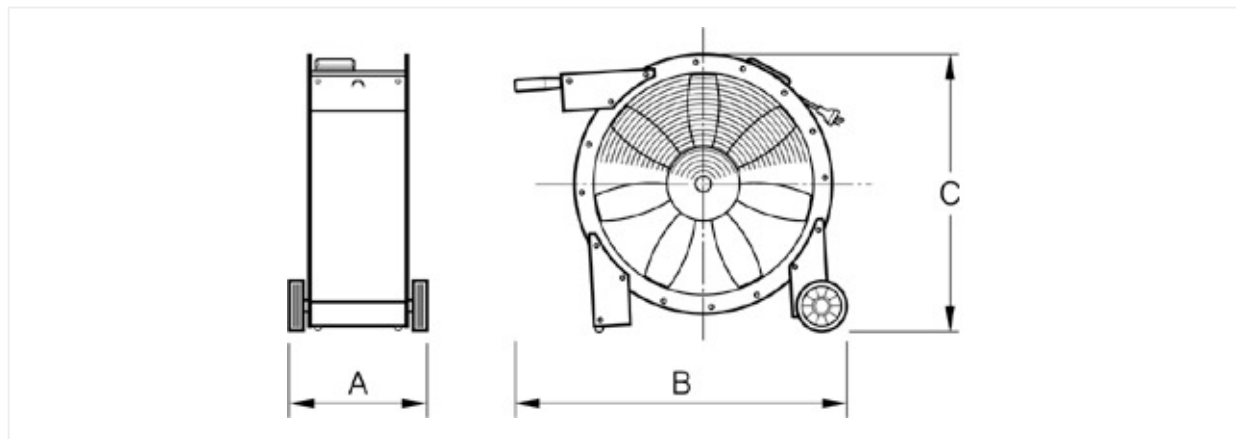

A	B	C
348	822	683

All dimensions in mm, unless otherwise stated

Contacts



OFFICES & AGENTS

Victoria

Fantech Pty. Ltd.
Tel:+61 (03) 9554-7845

New South Wales

Fantech Pty. Ltd.
Tel:+61 (02) 8811-0400

Uniair Distributors Pty. Ltd.

Tel:+61 (02) 4961-6088
Refrigeration and Air Supplies

Tel:+61 (02) 4226-5133
Fantech Pty. Ltd.
Tel:+61 (02) 6025-1866

South Australia

Fantech Pty. Ltd.
Tel:+61 (08) 8294-0530

Queensland

Air Design Pty. Ltd.
Tel:+61 (07) 3299-9888

Capricorn Air Conditioning

Tel:+61 (07) 4775-5222

Northern Territory

Fantech Pty. Ltd.
Tel:+61 (08) 8947-0447

Western Australia

Systemaire Pty. Ltd.
Tel:+61 (08) 9209-4999

Tasmania

Major Air Pty. Ltd.
Tel:+61 (03) 6344-6888

Hobart

Tel:+61 (03) 62736455

ACT

Idealair Group Pty. Ltd.
Tel:+61 (02) 6280-5511

Auckland

Fantech (NZ) Ltd.
Tel:+64 (09) 444-6266

Christchurch

Fantech (NZ) Ltd.
Tel:+64 (03) 379-8622

Wellington

Fantech (NZ) Ltd.
Tel:+64 (04) 566-0532