

## Connect to your WiFi

Ensure your mobile phone is connected to your 2.4GHz WiFi network.

Your mobile phone and your smart device needs to be within good signal strength range of your WiFi router.

## Download the BrilliantSmart App

Please download the free BrilliantSmart app from the App store or Google Play store, or scan the QR code below.

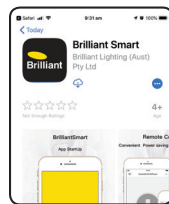

## Register the BrilliantSmart App

Open the BrilliantSmart app.

For new users, register a new account or if existing user, login with your user name and password.

## Configure your BrilliantSmart App

### Setting up your Home

You can setup multiple homes or locations. Click **'Add Home'** button. Or Click on **'Home'** top left if you are adding or modifying details then **'Home Management'** to setup your home(s), add or rename rooms and share devices.

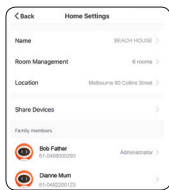

7

## Add your Smart Device to your App

1. Arrange installation of your smart device by a Licensed Electrician (refer installation instructions at start of this manual).
2. Once safely wired, you can pair/connect the device to the app. On initial power-on, the PIR sensor indicator light will begin flashing red and be ready to pair (2 times per second).  
*(If smart device does not start blinking, then press the reset button on the sensor until light starts to blink rapidly.)*
3. Open the BrilliantSmart App, tap **'Add Device'** (if empty room) or **'+'** to add your smart security light.
4. Select **'Lighting'** in the list of devices. If sensor LED indicator is blinking rapidly then press **'Confirm indicator rapidly blink'**.
5. Enter your home WiFi password.

Connection will now begin.

6. Once connected you'll get a menu **'Adding device succeeded'**. Select the room device and press **'Done'**. You can click on the pen to change the device name.

The smart device can now be controlled by the BrilliantSmart app.

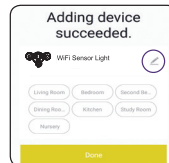
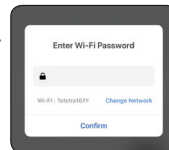
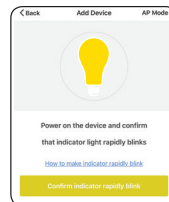

8

Go to [www.brilliantsmart.com.au](http://www.brilliantsmart.com.au) for full instructions and features.

## Warranty

Brilliant Lighting warrants this product against defects in manufacture and workmanship for a period of 2 years from date of purchase. Warranty does not include damage or loss arising from incorrect installation, operation or maintenance of this product, damage caused through modification, or incorrect installation.

Our goods come with guarantees that cannot be excluded under the Australian Consumer Law. You are entitled to a replacement or refund for a major failure and compensation for any other reasonably foreseeable loss or damage. You are also entitled to have the goods repaired or replaced if goods fail to be of acceptable quality and the failure does not amount to a major failure.

Any claim under this warranty must be made within 2 years of the date of purchase of the product.

Refer to our website [brilliantlighting.com.au](http://brilliantlighting.com.au) for terms and conditions and warranty claims.

This warranty is given by:

Brilliant Lighting (Aust) Pty. Ltd.  
ABN 37 006 203 694  
956 Stud Road Rowville, VIC 3178  
Phone: 03 9765 2555  
Email: [warranty@brilliantlighting.com.au](mailto:warranty@brilliantlighting.com.au)  
MADE IN CHINA

9

## Warning

1. To prevent injury, this apparatus must be installed by a licensed electrician.
2. Do not open or tamper with this product.
3. Do not allow children to play with wall switch turning ON/OFF rapidly. This can cause the Smart device to be reset.
4. Power surge/power loss could possibly reset Smart device. If this happens, follow the setup instructions.
5. The light source of this luminaire is not replaceable; when the light source reaches its end of life the whole luminaire shall need to be replaced.

**NB: BrilliantSmart app screens may differ due to application updates & improvements.**

## Disposal

Please dispose of this packaging material thoughtfully.

Please dispose of this product thoughtfully once it has passed its useful life. When your smart device comes to the end of its life or you choose to update or upgrade it, please do not dispose of it with your normal household waste. Please recycle where facilities exist.

When disposing of this fitting, check with your local authority for suitable options.

1920 09/19

10

## Troubleshooting

**Problem:**  
Smart device does not switch ON

Possible Cause	Suggested Solution
No Mains Power	Check connections, fuses and switches

**Problem:**  
Cannot link smart device with BrilliantSmart app

Possible Cause	Suggested Solution
1. Modem signal weak	Place device and modem closer together
2. Router/modem/smart phone firewall is enabled	Disable firewalls on all devices
3. Internet connection is down	Contact your provider
4. BrilliantSmart app not installed correctly	Remove app and re-install

For any other problems connecting your smart device to BrilliantSmart app please visit:  
[www.brilliantsmart.com.au/faq](http://www.brilliantsmart.com.au/faq)

### Brilliant Lighting

956 Stud Road  
Rowville Vic 3178 Australia

[www.brilliantlighting.com.au](http://www.brilliantlighting.com.au)

### Australian Sales

T 03 9765 2555  
T 1800 817 754 (interstate only)  
F 03 9763 0277  
E [warranty@brilliantlighting.com.au](mailto:warranty@brilliantlighting.com.au)

### New Zealand Sales

T 09 974 9618  
E [sales@brilliantlighting.co.nz](mailto:sales@brilliantlighting.co.nz)



# Escort WiFi Twin Heads Sensor Light 20700/06



USER MANUAL

11

## Box Content

Escort WiFi Twin Security light x 1  
User Manual x 1

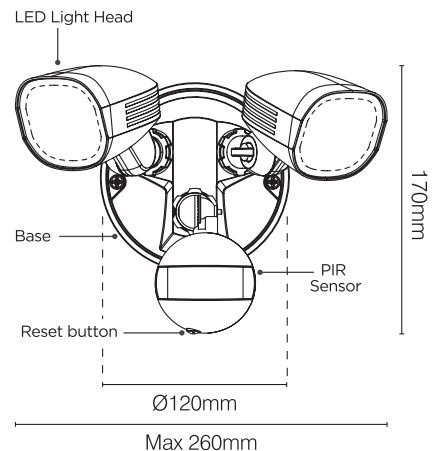

170mm

Ø120mm

Max 260mm

## Technical Specifications

**Model:** 20700/06

**Supply voltage:** 230/240V AC 50Hz

**Dimmable:** via BrilliantSmart App

**Time Duration:** 10s to 10min

**Detection Method:** PIR (Passive Infra-Red)

Adjustable Lux and Sensitivity

**Range:** 10m by 180° via app

**Manual Override:** via BrilliantSmart App

**LED Heads:** 2x11W Max

**Set Mode:** Auto-Override-Flash

**Sensor:** Low - Med - High

**Brightness:** 10% - 100%

**CCT:** 3000K - 6000K

**Lux:** 0 - 2000lux

**Weight of product:** 0.71kg

**Warranty:** 2 Years

**Security:** Mac Encryption; WEP/WAPI/TKIP/AES

**WiFi Standard:** IEEE802.11b/g/n

**System Req's:** iOS 8.0 or higher, Android 4.1 or higher

### Classification

- Class I Construction

- Smart Control

## Installation

**MUST BE INSTALLED BY A LICENSED ELECTRICIAN.**

**BEFORE INSTALLATION, PLEASE CHECK THAT THE LOCATION OF THE SMART DEVICE IS WITHIN RANGE OF YOUR HOME WIFI AND SIGNAL IS STRONG.**

## IMPORTANT SAFETY ISSUES

Ensure the power is disconnected before installing. This product is NOT suitable for damp or explosive environments. Modification of this product will void any warranty.

The installation must follow AS/NZS 3000 wiring rules and building codes.

When drilling into walls and ceilings, care must be taken to ensure you do not damage electrical wiring and other hidden utilities.

## INTRODUCTION

- Do not direct the heads upwards above horizontal.
- Always operate the sensor with sensor reset button facing downwards.

The twin head security light with sensor continuously scans the detection area and switches the light 'ON' when it detects movement.

This means that whenever movement is detected within the range of the sensor the light will be switched 'ON' automatically to illuminate pathways, steps, patios, porches, backyards or areas around the home. While there is movement within the detection range the light will stay 'ON'.

The twin head security light with sensor is designed for outdoor use in normal, clean conditions.

## BEFORE COMMENCING INSTALLATION

For the best performance we suggest you take into account the following:

- Do not face sensor towards direct sunlight.
- The detection efficiency is substantially lower when the movement is directly towards or away from the sensor.

- Best performance is achieved when the movement is **across** the detection area of the sensor.
- To avoid flickering and/or interference with other electronic/electrical equipment it is suggested to wire the security light into its own circuit with its own isolating switch.
- The recommended mounting height is 2m to 2.5m.
- To avoid false activation, the sensor should be directed away from heat sources such as barbecues, flue vents, air conditioners, other light fittings, moving objects, cars etc.
- Keep the security light away from strong electromagnetic fields.
- Do not install on surfaces which can move or vibrate.
- Do not face sensor towards reflective surfaces such as tiles, smooth white walls, swimming pools, etc.
- The sensor range is approximately 10m by 180°. This may vary slightly depending on the mounting height and the temperature.

## INSTALLATION

NOTE: For best performance install at a height between 2 and 2.5 metres.

1. Ensure the mains supply is switched 'OFF'.
2. Unpack the fixture carefully and dispose of the packaging material thoughtfully.
3. NOTE: The fitting must be wired to its own wall switch.
4. Remove the mounting plate 'B' from light body 'A' by unscrewing the front screws 'C'.
5. Drill two holes in the wall using the mounting

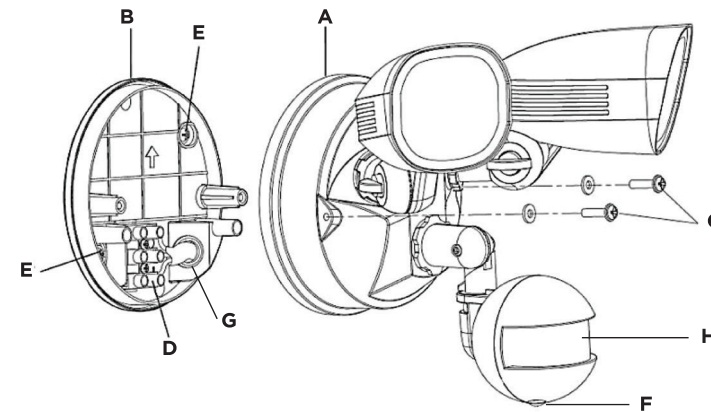

holes 'E' on the mounting plate 'B' as a template. Note: Exercise caution to avoid drilling into existing electrical wiring.

6. Feed mains supply cable through the wall and weatherproof holes as appropriate. Pierce the rubber grommet 'G' with a screwdriver and pass the mains supply cable through.
7. Use screws and suitable fixture system to secure the mounting plate 'B' to the wall securely.
8. Connect the Live (L) Neutral (N) and Earth ⚡ according to the markings on the terminal block 'D'.
9. Apply silicone if required around the base plate and grommet to maintain IP rating.

10. Refit the light body 'A' onto the mounting plate 'B', ensuring that the quick connect terminal is aligned correctly. Secure in place using two screws 'C' removed earlier. Tighten them firmly.

11. Loosen the wing nut on light head knuckle and angle each light head and sensor 'H' into desired direction, then re-tighten the wing nuts firmly. Note that reset button on the sensor 'F' must always face downwards. Light heads should not be faced above the horizontal.

12. Reconnect the mains supply.

13. Turn on the security light.

**Use the Brilliant Smart APP to adjust and control required parameters.**