

EV-DUO-CORE(-B)

- 1** Remove front by inserting a screwdriver into two slots and levering from body.

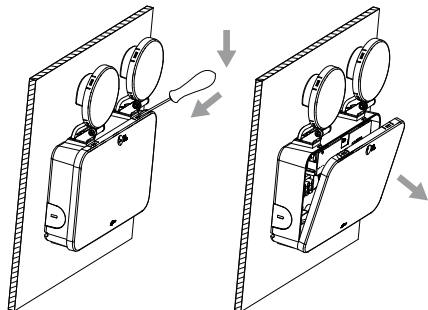

- 2** To mount to wall, screw through marked points in corners of case. Ensure holes are sealed appropriately to maintain IP rating.

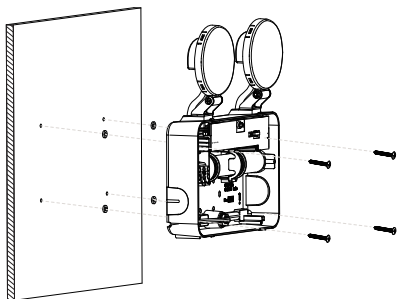

- 3** To mount to wall via hanging, screw hooks to body using the marked points. Secure screws to wall in marked positions. (Optional)

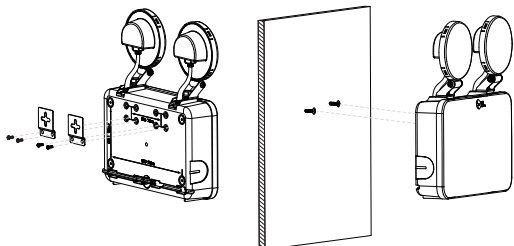

- 4** Wire terminal block

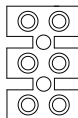

L Unswitched live

N Neutral

Strip length: 8-10mm
Wire range: 0.5-6.0mm²

- 5** Set LED configuration via switch located inside housing

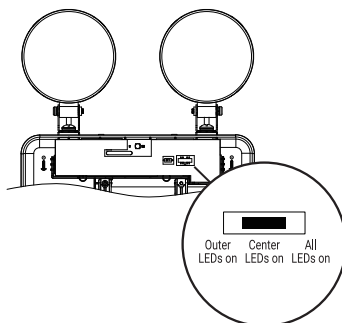

- 6** Replace front panel and ensure it is secured properly

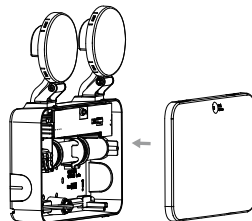

DIMENSIONS

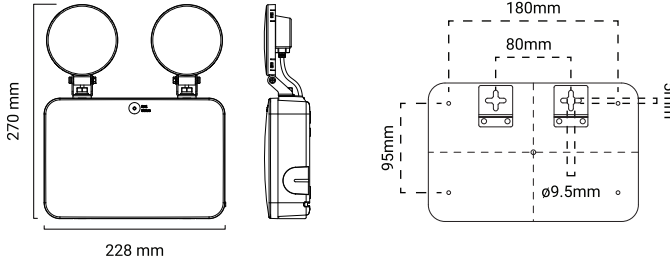

SPECIFICATIONS

Voltage	230V~ 50Hz	CCT	6000K	Battery Type	LiFePO ₄
Class	II	IP Rating	IP65	Battery Capacity	3.2V 3400mAh
Working Temp.	40°C	Mounting Type	Wall Mounted	Battery Code	18096
Max power consumption	2.5W	Wiring	Terminal Block	Charging Time	16 Hours
Average power consumption	1.0W	Duration	90 min	Charger Type	Variable

BATTERY LIFE

To maintain the economic life of this product it is required that the battery be discharged and recharged at least once every 6 months. The battery life can be reduced if the battery is not discharged as per the requirements of AS/NZS 2293 or an equivalent standard. Increasing the number of duration tests above that as defined in AS/NZS 2293 or an equivalent standard can have a positive effect on the battery performance as long as 12 discharge cycles per year is not exceeded. The recharging device will operate normally after removal of short circuit fault.

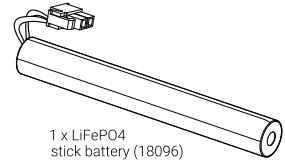

TEST SWITCH

Action	Function
Hold	Run in emergency mode

STATUS CHARGE LEDS (GREEN)

Indicator	Meaning
On	Battery charging
Battery test*	
2x flash	Battery full
4x flash	NTC noncharge
5x flash	Battery charge
3 x flash	Lamp failure
Off	Battery charger off/disconnected

*After emergency test mode is activated via test switch

ORDERING INFORMATION

SKU	Product code	Description
12144	EV-DUO-CORE	Duo Core Emergency Luminaire
12145	EV-DUO-CORE-B	Duo Core Emergency Luminaire - Black

REPLACING THE BATTERY

Access the battery by removing the gear tray. Disconnect and remove battery. Replace battery as was previously installed. Battery can be connected in one direction only, do not force. Allow a minimum 24 hours charging time before carrying out any discharge tests as per the requirements in AS/NZS 2293.



SAFETY WARNINGS

- This product must only be installed by a licensed electrician.
- Before commencing installation turn off and isolate the electrical supply.
- Risk of accidental contact with live parts. do not energise with product open or disassembled.
- Mains supply and battery circuit separated by reinforced insulation.
- The only user serviceable / replaceable part is the battery pack.
- Do not attempt to service other parts of the fitting as this will void the warranty.
- After installation allow the battery to charge for 24 hours before carrying out discharge testing.
- As the installer, it is your responsibility to ensure you comply to all relevant building and safety codes.
- The light source contained in this luminaire shall only be replaced by the manufacturer or their service agent or a similar qualified person.
- The replacement of the battery is needed when they no longer meet their rated duration of operation after the corresponding recharge period.
- This luminaire is intended only for mounting in locations where the plug and socket are protected from unauthorized disconnection.
- All maintenance, such as battery change on this luminaire to be performed by qualified personnel only. De-energise all supplies before maintenance.