

PE Racing Pedal Box

PE-001-1001

Dimensions & Specifications

Cable Throttle Version

SPECIFICATIONS

- Materials : 6061-T6 & 5005-H34 Alloys, Tig Welded Alloy Construction
- Finish: Anodised in Black & Clear
- Master Cylinders: Alloy Construction with 34.9mm stroke (1.375")
- Mounting Location: Floor and Firewall, or Floor and Bulkhead
- Reservoir Capacity: 3 off Remote mounted Plastic with 105cc Fluid Capacity each
- Reservoir Dimensions: 76.2mm (3") diameter and 88.9mm (3.5") high
- Hydraulic Feed Lines: Teflon lined Stainless Braided Hose AN-4 Fittings
- Fixings: Stainless Steel
- Pins : Titanium Gr2
- Net Weight: 4lb 7oz (2.02kg)
Incl. Throttle Linkage Kit
- Gross Weight: 7lb 11oz (3.45kg)
Incl. Master Cylinders, Balance Bar & Fittings
- Pedal Ratio: Adjustable 3.5:1 to 3.9:1



Safe Working Loads

- Clutch Pedal Force 90kg (138 Lb Or 883 N)
- Brake Pedal Force 160kg (352 Lb Or 1570 N)
- Throttle Pedal Force 50kg (110 Lb Or 490 N)
- Throttle Cable Force 10kg (22 Lb Or 98 N)
- Return Spring Force 5kg (11 Lb Or 50 N)

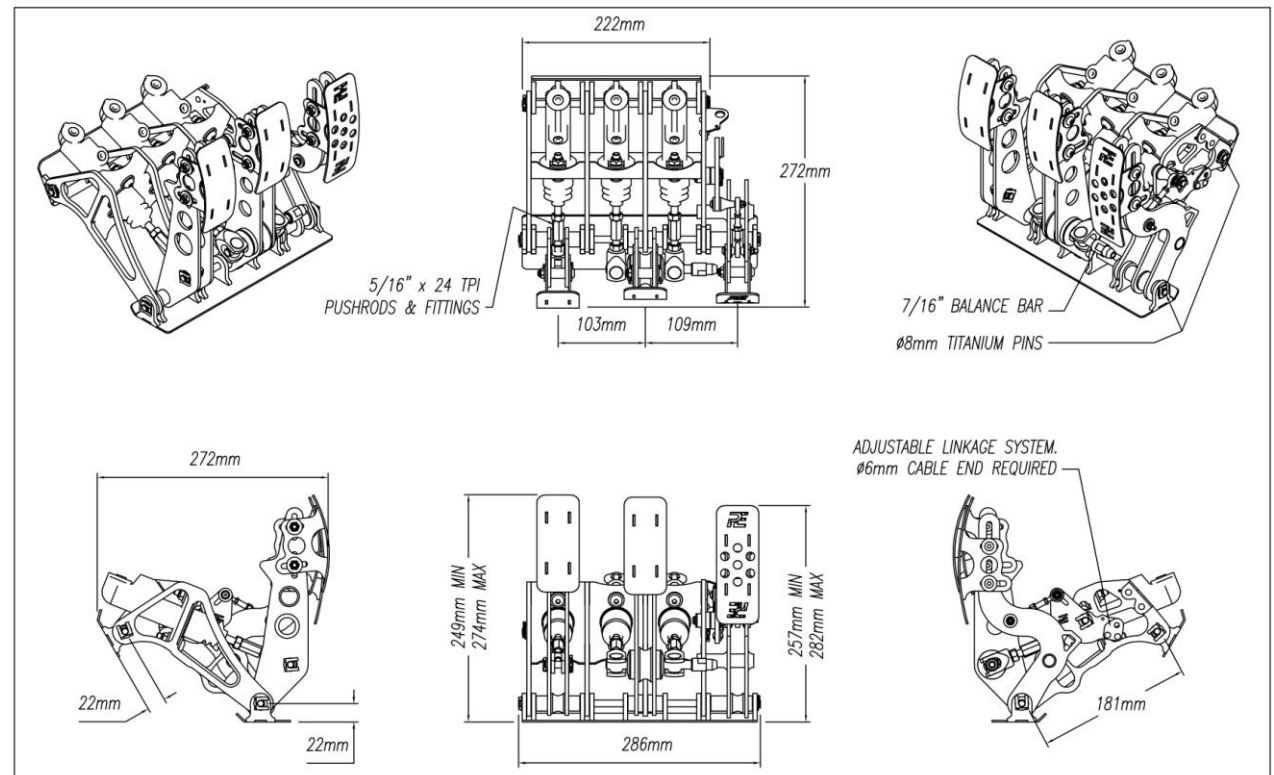

PE Racing Pedal Box

PE-002-1001

Dimensions & Specifications

Drive by Wire Throttle Version

SPECIFICATIONS

- Materials : 6061-T6 & 5005-H34 Alloys, Tig Welded Alloy Construction
- Finish: Anodised in Black & Clear
- Master Cylinders: Alloy Construction with 34.9mm stroke (1.375")
- Mounting Location: Floor and Firewall, or Floor and Bulkhead
- Reservoir Capacity: 3 off Remote mounted Plastic with 105cc Fluid Capacity each
- Reservoir Dimensions: 76.2mm (3") diameter and 88.9mm (3.5") high
- Hydraulic Feed Lines: Teflon lined Stainless Braided Hose AN-4 Fittings
- Fixings: Stainless Steel
- Throttle Torsion Spring: stainless Steel
- Pins : Titanium Gr2
- Net Weight: 4lb 7oz (2.07kg)
Incl. Throttle Linkage Kit
- Gross Weight: 7lb 11oz (3.5kg)
Incl. Master Cylinders, Balance Bar & Fittings
- Pedal Ratio: Adjustable 3.5:1 to 3.9:1
- Dual Output Throttle Position Sensor, Non-Contact 180°, Input 5V±0.25V DC, Output 0.5 V - 4.5V DC

Safe Working Loads

- Clutch Pedal Force 90kg (138 Lb Or 883 N)
- Brake Pedal Force 160kg (352 Lb Or 1570 N)
- Throttle Pedal Force 50kg (110 Lb Or 490 N)
- Return Spring Force 5kg (11 Lb Or 50 N)

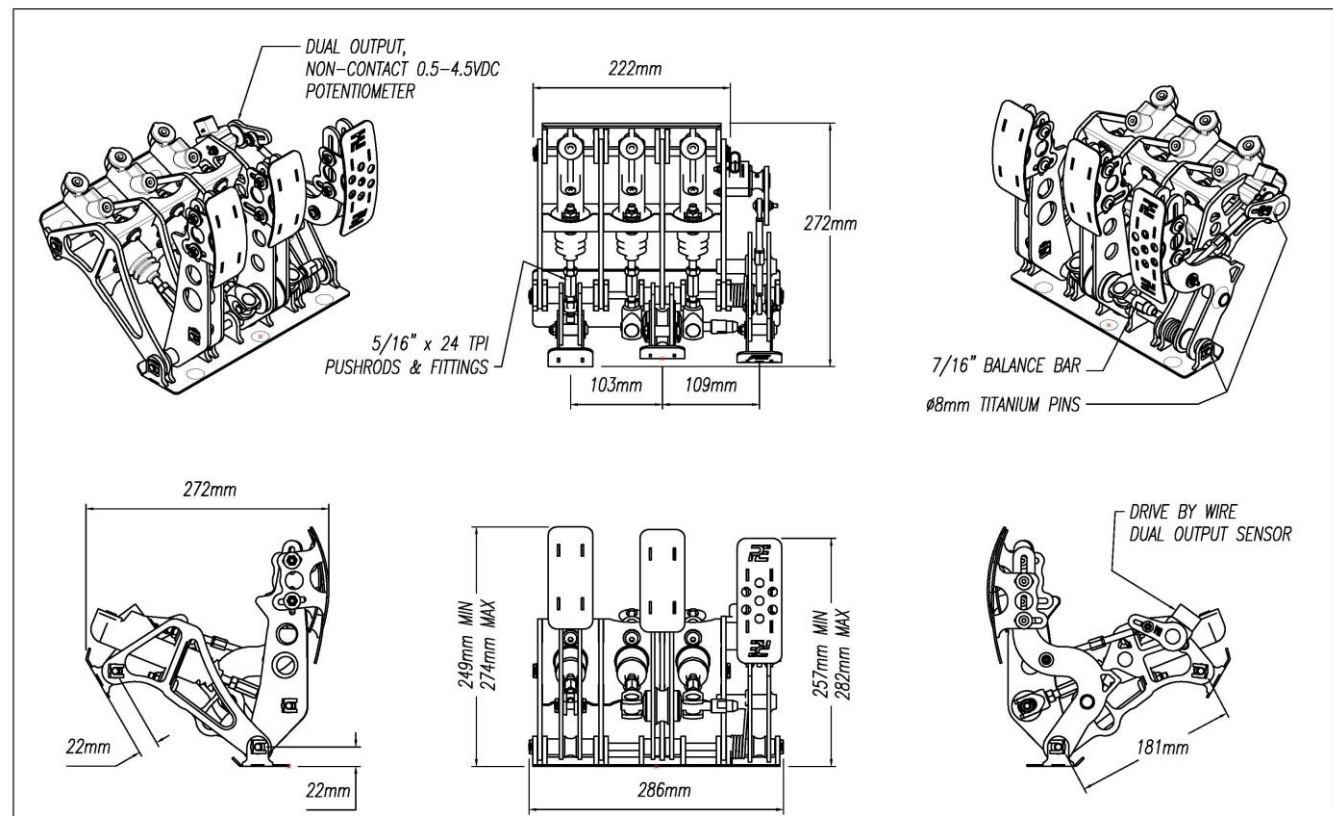

PE-001-1001 & PE-002-1001-DBW/CABLE CONTENT KIT

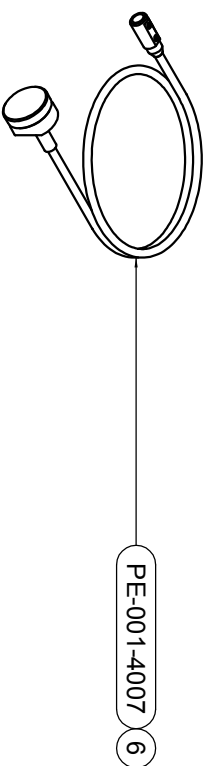
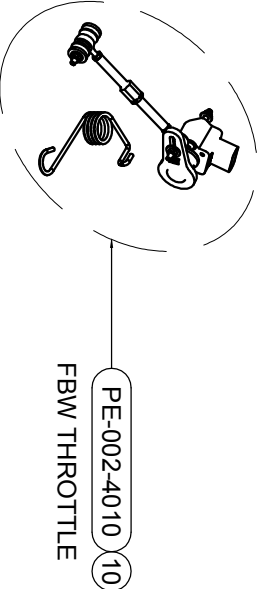
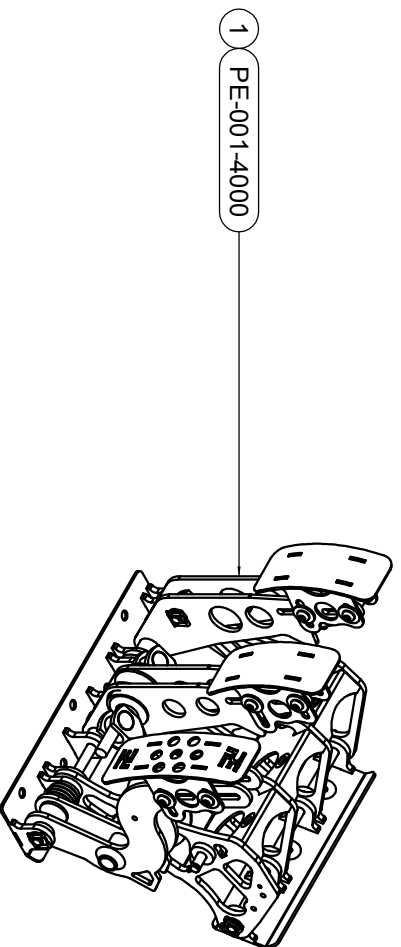
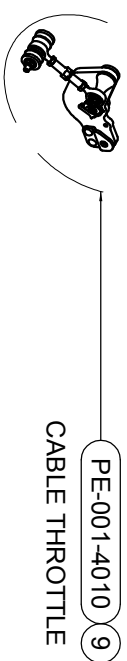
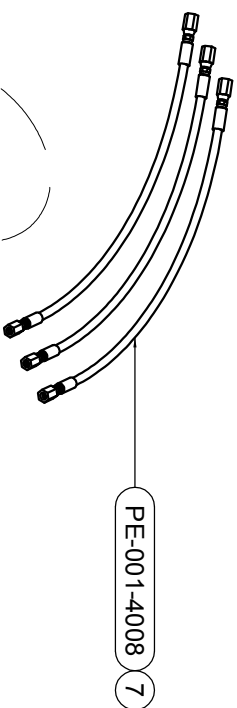
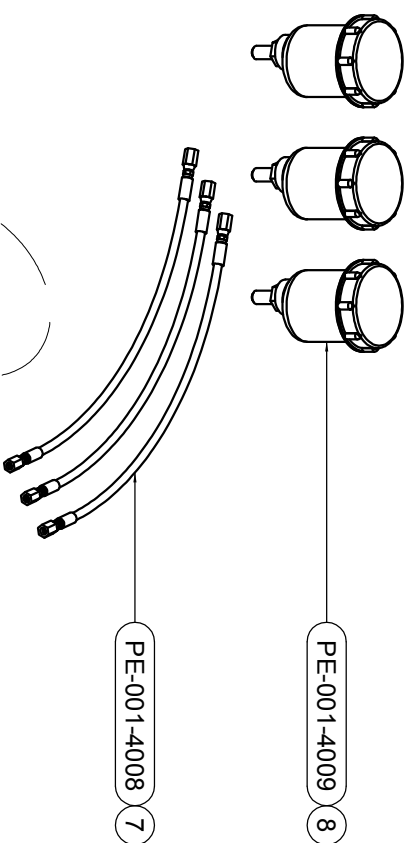
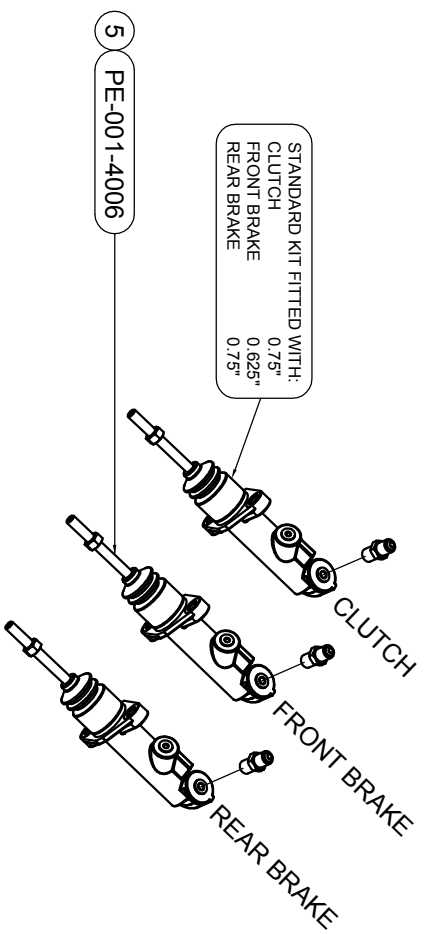

SPARE PARTS (CABLE & DRIVE BY WIRE THROTTLE VERSIONS)			
ITEM	DESCRIPTION	ASSY PART NUMBER	QTY
1	NET Pedal ASSY	PE-001-1000	1
2	CLUTCH PEDAL ASSY	PE-001-4002	1
3	BRAKE PEDAL ASSY	PE-001-4003	1
4	THROTTLE PEDAL ASSY	PE-001-4004	1
5	MASTER CYLINDERS	PE-001-4006	3
6	BIAS ADJUSTER CABLE	PE-001-4007	1
7	RESERVOIR HOSES	PE-001-4008	3
8	FLUID RESERVOIRS	PE-001-4009	3
9	CABLE THROTTLE LINKAGE ASSY	PE-001-4010	1
10	FBW THROTTLE LINKAGE ASSY	PE-002-4010	1

MASTER CYLINDER DESIGNATION

PART NUMBER	BORE	STROKE	INLET PORT	OUTLET PORT	AREA IN ²	VOLUME IN ³
PE-001-3039	0.625"	1.375"	AN-4 7/16" x 20 TPI	AN-3 3/8" x 24 TPI	0.307	0.422
PE-001-3040	0.7"	1.375"	AN-4 7/16" x 20 TPI	AN-3 3/8" x 24 TPI	0.385	0.529
PE-001-3041	0.75"	1.375"	AN-4 7/16" x 20 TPI	AN-3 3/8" x 24 TPI	0.442	0.607