

PE Racing Auto Pedal Box

PE-003-1001

Dimensions & Specifications

Cable Throttle Version

SPECIFICATIONS

- Materials : 6061-T6 & 5005-H34 Alloys, Tig Welded Alloy Construction
- Finish: Anodised in Black & Clear
- Master Cylinders: Alloy Construction with 34.9mm stroke (1.375")
- Mounting Location: Floor and Firewall, or Floor and Bulkhead
- Reservoir Capacity: 2 off Remote mounted Plastic with 105cc Fluid Capacity each
- Reservoir Dimensions: 76.2mm (3") diameter and 88.9mm (3.5") high
- Hydraulic Feed Lines: Teflon lined Stainless Braided Hose AN-4 Fittings
- Fixings: Stainless Steel
- Pins : Titanium Gr2
- Net Weight: 3lb 8oz (1.6kg) Incl. Throttle Linkage Kit
- Gross Weight: 5lb 8oz (2.5kg) Incl. Master Cylinders, Balance Bar & Fittings
- Pedal Ratio: Adjustable 3.5:1 to 3.9:1



Safe Working Loads

- Brake Pedal Force 160kg (352 Lb Or 1570 N)
- Throttle Pedal Force 50kg (110 Lb Or 490 N)
- Throttle Cable Force 10kg (22 Lb Or 98 N)
- Return Spring Force 5kg (11 Lb Or 50 N)

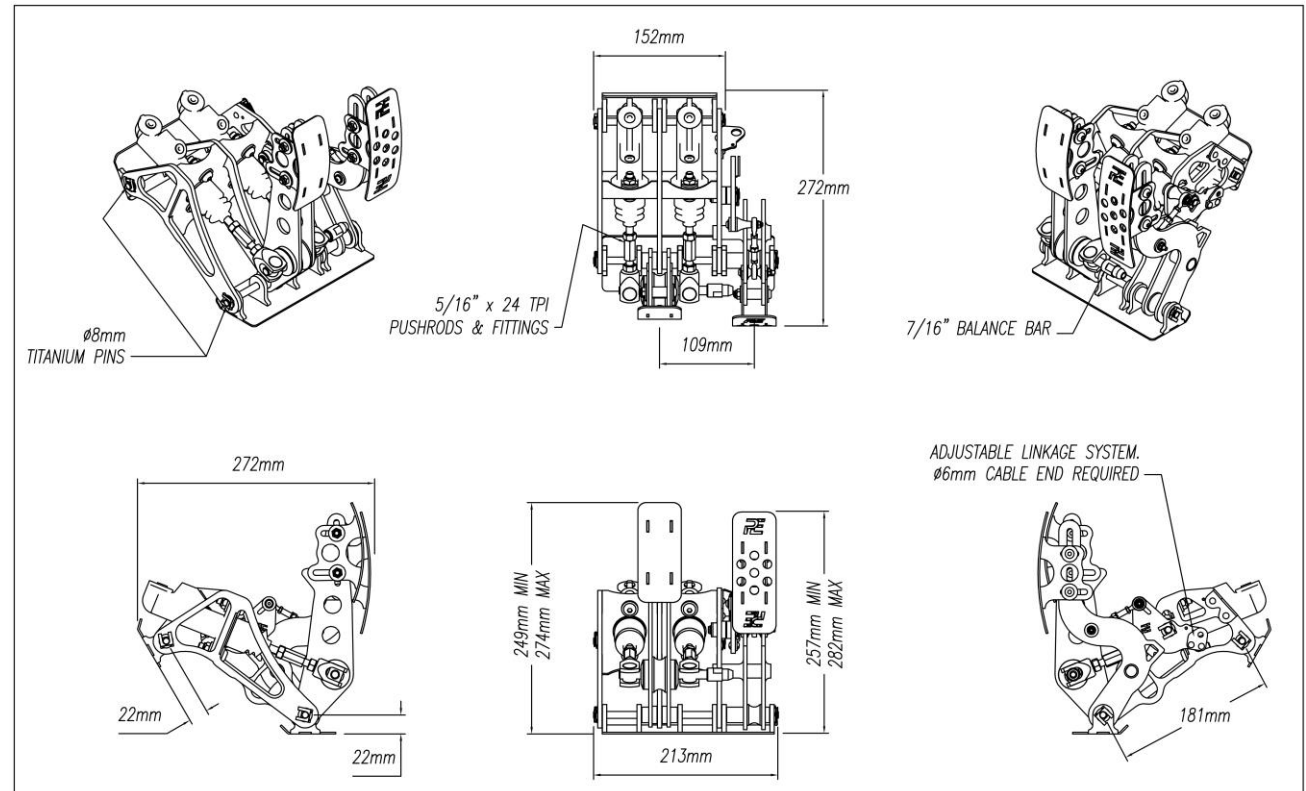

PE Racing Auto Pedal Box

PE-004-1001

Dimensions & Specifications

Drive by Wire Throttle Version

SPECIFICATIONS

- Materials : 6061-T6 & 5005-H34 Alloys, Tig Welded Alloy Construction
- Finish: Anodised in Black & Clear
- Master Cylinders: Alloy Construction with 34.9mm stroke (1.375")
- Mounting Location: Floor and Firewall, or Floor and Bulkhead
- Reservoir Capacity: 2 off Remote mounted Plastic with 105cc Fluid Capacity each
- Reservoir Dimensions: 76.2mm (3") diameter and 88.9mm (3.5") high
- Hydraulic Feed Lines: Teflon lined Stainless Braided Hose AN-4 Fittings
- Fixings: Stainless Steel
- Pins : Titanium Gr2
- Net Weight: 3lb 8oz (1.6kg)
Incl. Throttle Linkage Kit
- Gross Weight: 5lb 8oz (2.5kg) Incl. Master Cylinders, Balance Bar & Fittings
- Pedal Ratio: Adjustable 3.5:1 to 3.9:1

Safe Working Loads

- Brake Pedal Force 160kg (352 Lb Or 1570 N)
- Throttle Pedal Force 50kg (110 Lb Or 490 N)
- Return Spring Force 5kg (11 Lb Or 50 N)

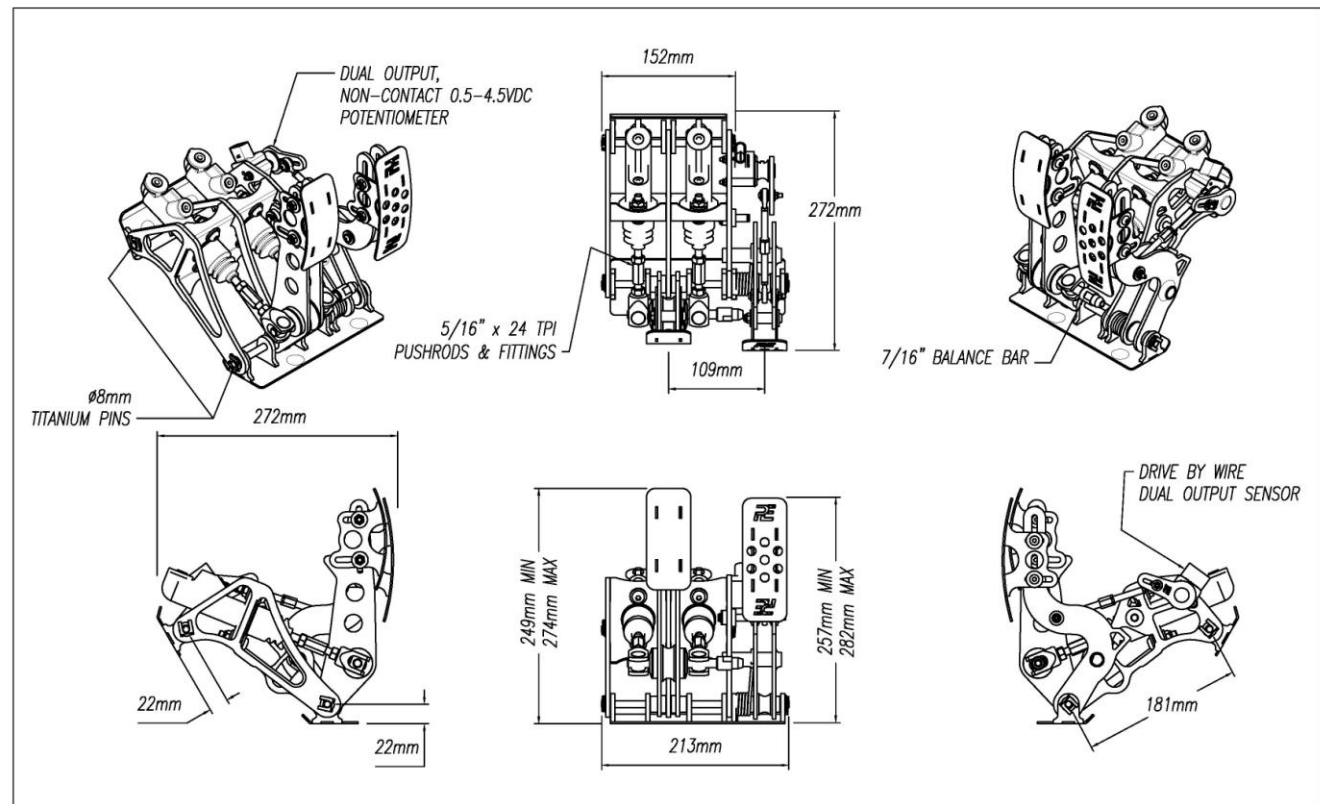

PE-003-1001 & PE-004-1001 -DBW/CABLE CONTENT KIT

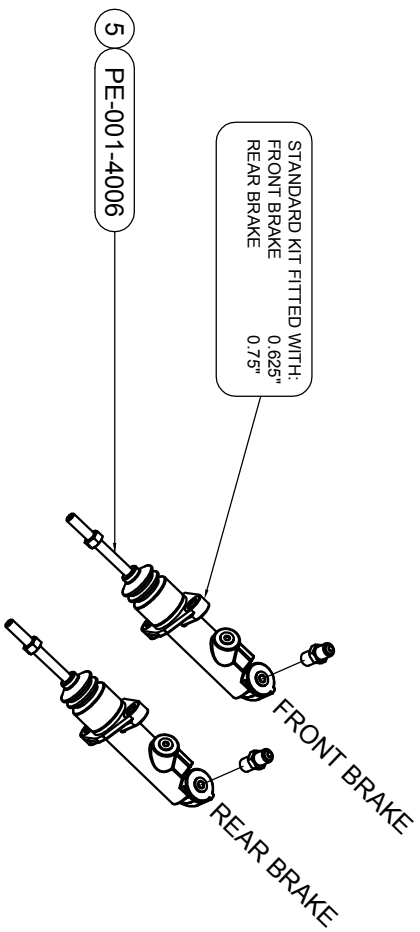

5 PE-001-4006

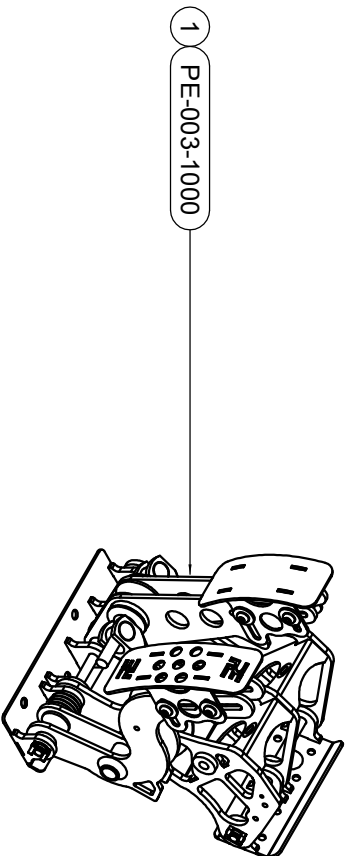

1 PE-003-1000

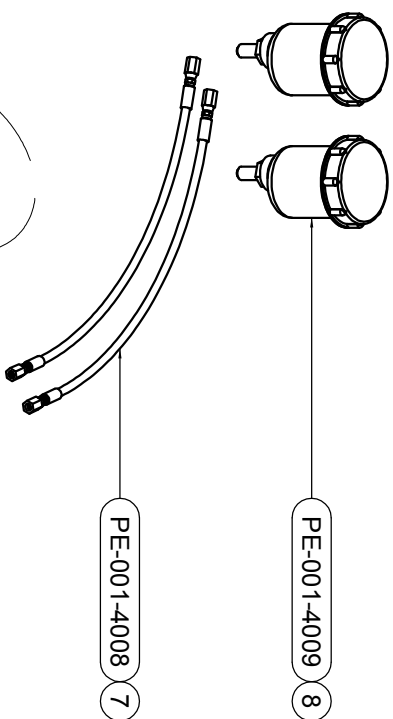

8 PE-001-4009

7 PE-001-4008

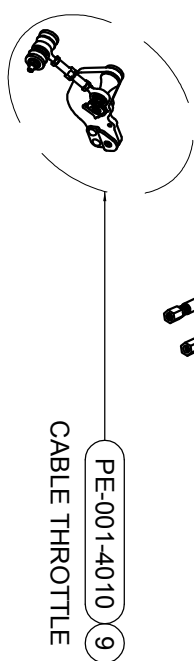

9 PE-001-4010

CABLE THROTTLE

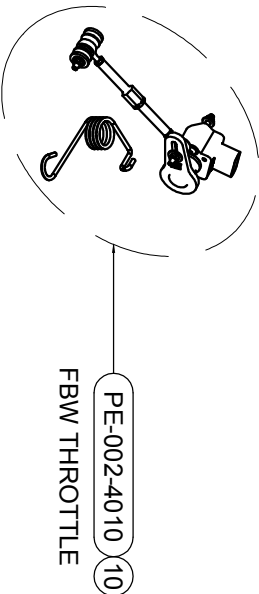

10 PE-002-4010

FBW THROTTLE

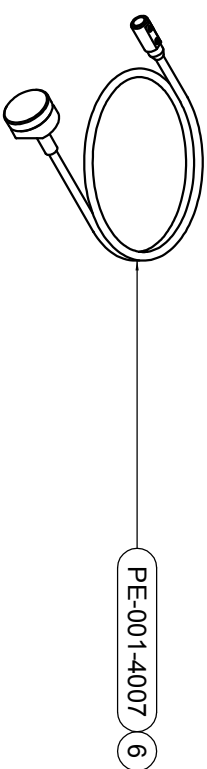

6 PE-001-4007

SPARE PARTS (CABLE & DRIVE BY WIRE THROTTLE VERSIONS)			
ITEM	DESCRIPTION	ASSY PART NUMBER	QTY
1	NET Pedal ASSY	PE-003-1000	1
5	MASTER CYLINDERS	PE-001-4006	2
6	BIAS ADJUSTER CABLE	PE-001-4007	1
7	RESERVOIR HOSES	PE-001-4008	2
8	FLUID RESERVOIRS	PE-001-4009	2
9	CABLE THROTTLE LINKAGE ASSY	PE-001-4010	1
10	FBW THROTTLE LINKAGE ASSY	PE-002-4010	1

MASTER CYLINDER DESIGNATION

PART NUMBER	BORE	STROKE	INLET PORT	OUTLET PORT	AREA IN ²	VOLUME IN ³
PE-001-3039	0.625"	1.375"	AN-4 7/16" x 20 TPI	AN-3 3/8" x 24 TPI	0.307	0.422
PE-001-3040	0.7"	1.375"	AN-4 7/16" x 20 TPI	AN-3 3/8" x 24 TPI	0.385	0.529
PE-001-3041	0.75"	1.375"	AN-4 7/16" x 20 TPI	AN-3 3/8" x 24 TPI	0.442	0.607