



# COYOTE 2.1

MAN-G00794



Visit us on / 拜訪我們 / Visitateci su / Besuchen sie uns auf / Visitez notre site  
[www.carisma-shop.com](http://www.carisma-shop.com)

©2021 Carisma. All Rights Reserved. Product specifications are subject to change. Same models shown are prototypes which may vary slightly from what is inside.  
©2021 Carisma. 版權所有。產品規格可能會更改。所示的相同型號均為原型，可能會略有不同。從裡面的東西。  
©2021 Carisma. Tutti i diritti riservati. Le caratteristiche del prodotto sono soggette a modifiche. Alcuni prodotti mostrati sono prototipi e possono differire leggermente da quanto fornito.  
©2021 Carisma. Alle Rechte vorbehalten. Die Eigenschaften der Produkte können Änderungen unterliegen. Einige dargestellte Produkte sind Prototypen und können leicht von dem Inhalt unterscheiden.  
©2021 Carisma. Tous droits réservés. Les spécifications du produit peuvent changer. Certains modèles présentés sont des prototypes qui peuvent être légèrement différents du modèle commercialisé.



# COYOTE 2.1

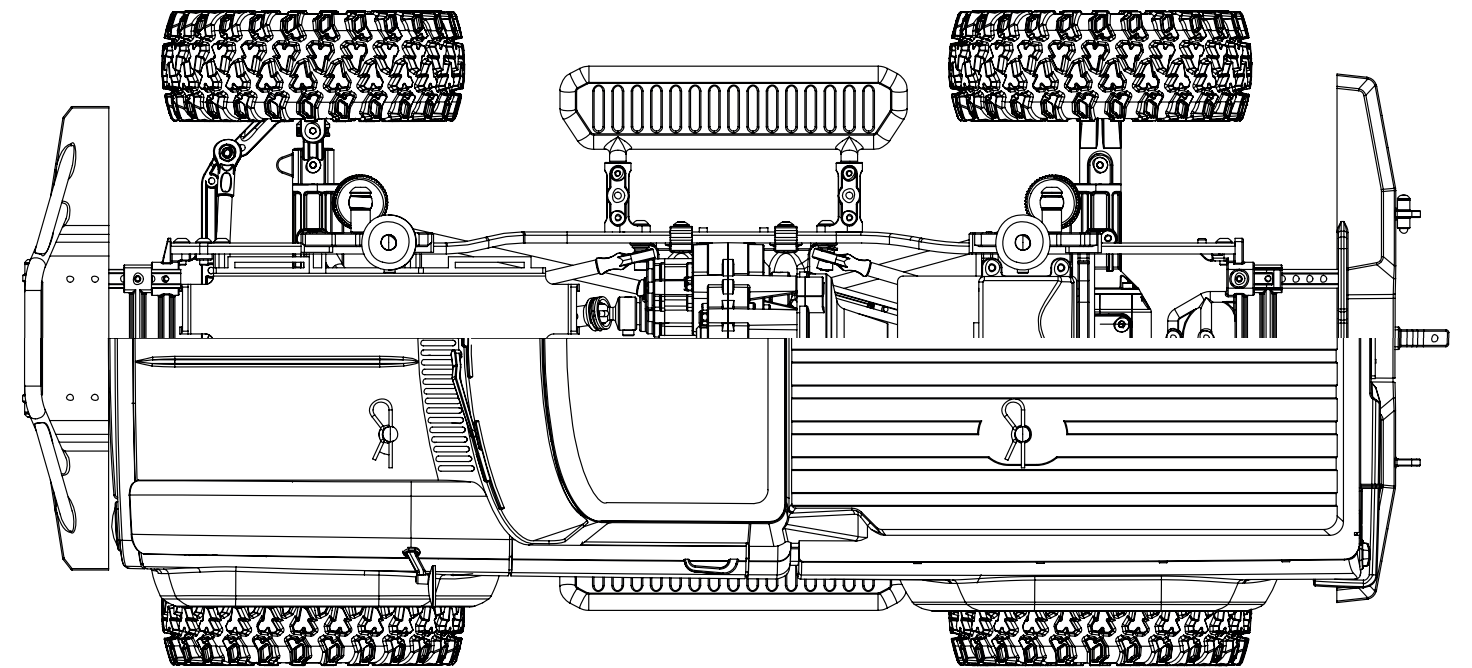

**SCA-1E 2.1**  
1/10TH 4WD SCALE CRAWLER KIT

## INSTRUCTION MANUAL

# SCA-1E 2.1 KIT

1/10TH 4WD SCALE CRAWLER



Thank you for purchasing our latest release, and welcome to the ever growing world of Carisma Scale Adventure!

The SCA-1E 2.1 Kit has been designed by scale enthusiasts, for scale enthusiasts. It offers an affordable way into the self-build scale scene and will allow the end user to tailor it's final look and performance to their own taste and abilities. Go as detailed or as simple with the build as you feel. Make the kit an extension of your own personality and personalized it any way you want. The adventure starts the moment you open the box, and continues every time you add to the scale detail, run, and further modify the rig.

Build it stock and run trails with ease, embark on milder forms of rock crawling, and own a rig that's not only very capable, its also extremely durable too. Detail the body, weight the wheels, tune the shocks and spend time getting the component layout just right for the optimum weight bias, and you have a rig that's DNA has been proven to not only be Recon G6 capable, the stock RTR being fully G6 Certified in 2017 over a gruelling 12 hour Fix Enduro. We've taken that original design and improved it further for the kit.

The kit sports a CMS (Chassis Mounted Servo), with a forward mounted battery tray to fully optimize weight bias and improve the rigs crawling capabilities. We've also designed a new true beadlock wheel system, soft compound all terrain tyres and improved upper shock mounts and chassis bracing. The SCA-1E 2.1 has evolved, but the price point remains competitive and affordable to all.

The SCA-1E 2.1 is easy to build using standard RC tools, easy to maintain between runs or competitions and easy to modify or hop up using many existing third party scale parts and accessories. Carisma Scale Adventure also produces a range of official hop ups and performance parts in both CNC alloy and high performance plastics.

Keep up to date with all the latest information, product releases and setup tips from our team drivers on our dedicated website: - [www.carismascaleadventure.com](http://www.carismascaleadventure.com) and get social with us on Facebook, Instagram, Twitter and TikTok.

*"Buying your SCA-1E 2.1 is just the start of the adventure, where it takes you, is up to you ..."*

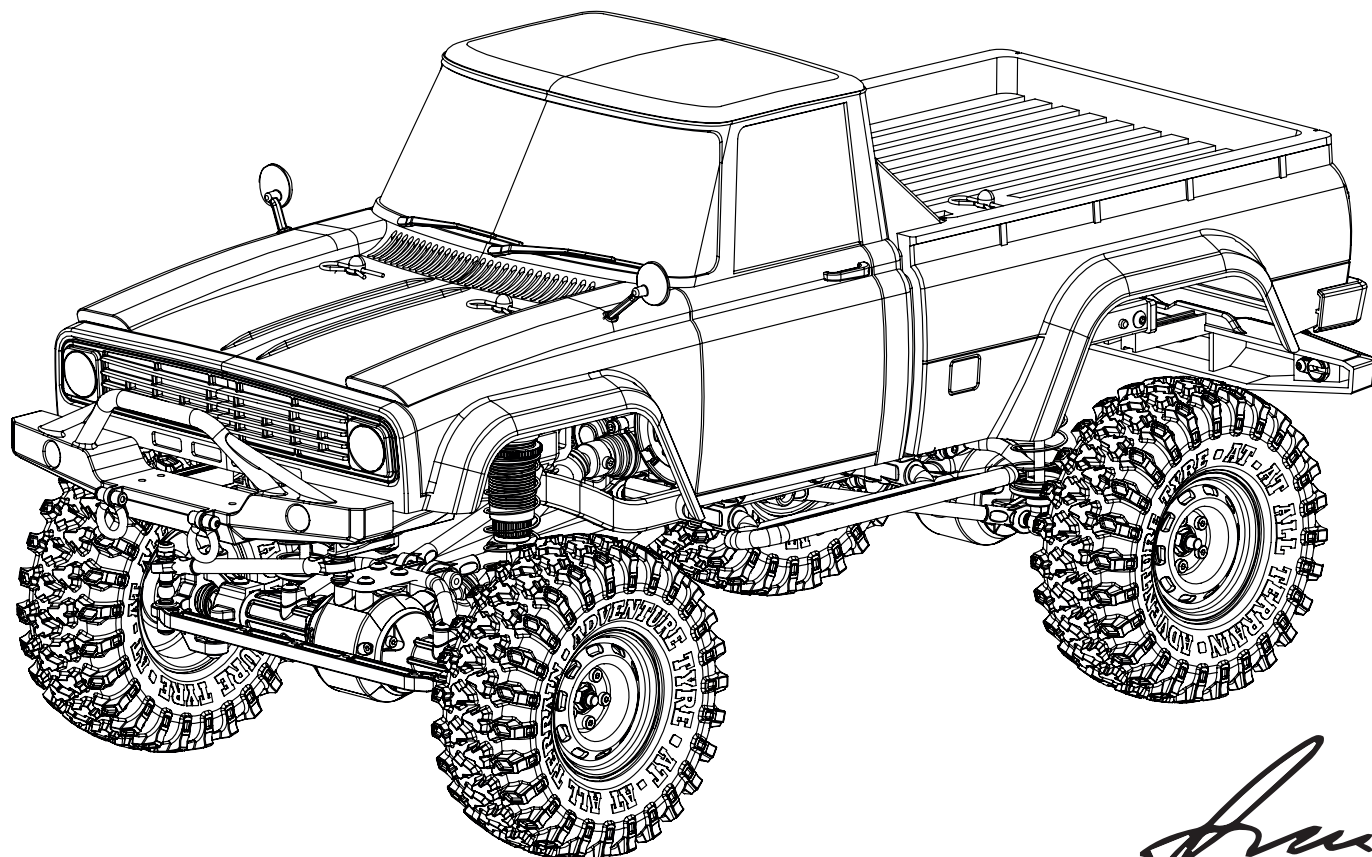

*Ivan Carisma*

## Safety Precautions

THIS MODEL IS ONLY SUITABLE FOR PEOPLE 14 YEARS OLD AND UP.  
THIS RADIO CONTROL MODEL IS NOT A TOY.

Beginner should seek advice from experienced person in order to assemble the model or parts correctly and to make best performance.

\* Assemble this model or parts only in place out of children's reach, and take safe precautions before operating this model. User is fully responsible for the model assembly and safe operations.

## Introduction

This is a sophisticated hobby product and not a toy. It must be operated with caution and common sense. User also requires some basic mechanical abilities.

Fail to operate this product in a safe and responsible manner could result in injury or do damage to the product or other properties. This product is not intended for use by children without direct adult supervision. The product manual contains instructions for safe operation and maintenance.

It is essential to read and follow all the instructions and warnings in the manual prior to assembly, setup or use, in order to operate correctly and avoid damage or injury.

## Safety, Precautions and Warning

As the user of this product, you are solely responsible for operating it in a manner that does not endanger yourself and others or result in damage to the product or the property of others.

This model is controlled by a radio signal that is subject to interference from many sources outside your control. This interference can cause momentary loss of control so it is necessary to always keep a safe distance in all directions around your model, as this will help to avoid collisions or injury. order to operate correctly and avoid damage or injury.

- Always operate your model in an open area away from cars, traffic, or people.
- Avoid operating your model on the street where injury or damage can occur.
- Never operate the model out into the street or populated areas for any reason.
- Never operate your model with low transmitter batteries.
- Carefully follow the directions and warnings for this product and any optional support equipment's (chargers, rechargeable battery packs, etc.) that you use.
- Keep all chemicals, small parts and anything electrical out of the reach of children.
- Moisture causes damage to electronics. Avoid water exposure to all equipment's not specifically designed and protected for this purpose.

It is the buyer's responsibility to ensure safety precautions in operating this model. You are responsible for the assembly and operations of this model. Please read the manual thoroughly and always keep it at hand for all times for reference. ONLY use Carisma/Carisma Racing parts for maximum performance. 3rd party parts installation will immediately void warranty. Improper operations may cause personal or property damage. Carisma/Carisma Racing or our distributors are NOT responsible for the damage in any way resulting from Shipping, improper construction or improper

The SCA-1E 2.1 is a high quality 1/10th scale 4WD off road, Trail and scale crawler, recommended for persons of 14 years and older. It is NOT a TOY, it is a precision self build kit. Adult supervision is required at all times during assembly and operating.

If in doubt, ask your fellow RC enthusiasts for advice or contact your local hobby store or countries distributor for assistance. We are constantly improving and developing all our products and therefore the exact specifications of the kit may change from batch to batch without prior notice.

This product contains a chemical known to the State of California to cause cancer and birth defects or other reproductive harm.

Carisma Scale Adventure guarantees this model kit to be free from defects in both materials and workmanship at point of purchase. The total monetary value under warranty will NOT, at any case what so ever be exceed the cost of the original kit purchased. This warranty does not cover any components damaged by use or modifications or wear. Part of parts missing from this kit must be reported within 30 days of purchase.

Proof of purchase must be sent at all time when applying for a claim under warranty. Should you find defective or missing part, contact your local distributor. Your local service and customer support will be your first point of contact. Always buy from your local stores where you can get the best customer support.





感谢您购买我们的最新版本，并欢迎您  
到Carisma Scale Adventure不断发展的世界！

SCA-1E 2.1套件是由电子秤爱好者为电子秤爱好者设计的。它提供了一种以经济实惠的方式进入自定标度场景的方法，并使最终用户可以根据自己的口味和能力定制其外观和性能。

根据您的感觉，尽可能详细或简单地进行构建。使该工具包成为您自己个性的扩展，并可以根据需要对其进行个性化设置。冒险从打开盒子的那一刻开始，每次添加到比例详细信息，运行并进一步修改装备时，冒险都会继续。

轻松地建立库存并运行小径，进行较温和的攀岩，并拥有不仅功能强大，而且也非常耐用的钻机。细化车身，给车轮加重，调整冲击力并花时间调整组件布局，以达到最佳的重量偏差，而您的装备已被证明不仅具有Recon G6的能力，而且其RTR完全通过了G6认证。在2017年历经了12个小时的艰苦修复Fixuro。我们采用了原始设计，并对套件进行了进一步改进。

该套件带有CMS（底盘安装伺服系统），并带有向前安装的电池托盘，可充分优化重量偏差并改善钻机的爬行能力。我们还设计了一种新的真正的胎圈锁车轮系统，可优化所有地形轮胎，并改进了上部减震装置和底盘支撑。SCA-1E 2.1不断发展，但价格仍然具有竞争力，并且所有人都可以负担得起。SCA-1E 2.1易于使用标准的RC工具进行制造，易于在每次运行或比赛之间进行维护，并且易于使用许多现有的第三方磅秤零件和附件进行修改或升级。Carisma Scale Adventure还使用CNC合金和高性能塑料生产一系列官方的跃点和功能部件。

在我们专用的网站上，从我们的团队驱动程序中获取所有最新信息，产品发布和设置提示，以获取最新信息：-

www.carismascaleadventure.com，并通过Facebook，Instagram，Twitter和TikTok与我们联系。

“购买SCA-1E 2.1只是冒险的开始，取决于您，这取决于您.....”

### 安全须知

此模型仅适用于14岁及以上的人。  
此无线电控制模型不是玩具。  
初学者应向有经验的人寻求建议，以正确组装模型或零件并获得最佳性能。  
\*仅在儿童接触不到的地方组装此型号或零件，并在操作此型号之前采取安全预防措施，用户对模型组装和安全操作负全部责任。

### 介绍

这是一种精致的爱好产品，而不是玩具。必须谨慎和常识地进行操作。用户还需要一些基本的机械能力。不以安全和负责任的方式操作本产品可能会导致人身伤害或损坏产品或其他性能。未经成人直接监护，本产品不适合儿童使用。产品手册包含有关安全操作和维护的说明。为了正确操作并避免损坏或伤害，在组装、设置或使用本手册之前，请务必阅读并遵守本手册中的所有说明和警告。

### 安全、注意事项和警告

作为本产品的用户，您应独自负责以不会危害自己和他人或不损害产品或他人财产的方式来操作本产品。此模型由无线电信号控制，该无线电信号可能会受到控件外部许多来源的干扰。这种干扰会导致瞬间失控，因此必须始终在模型周围的所有方向上保持安全距离，因为这将有助于避免碰撞或伤害。为了正确操作并避免损坏或伤害。

- 始终在远离汽车、交通或人员的空旷区域操作模型。
- 避免在可能会造成人身伤害或损坏的街道上操作模型。
- 切勿出于任何原因将模型运用于街道或人口稠密的地区。
- 切勿在变速器电池电量低的情况下操作模型。
- 请认真遵守本产品以及您使用的任何可选支持设备（充电器、可充电电池组等）的说明和警告。
- 将所有化学药品、小零件和任何电气设备置于儿童接触不到的地方。
- 水分会损坏电子设备。避免将水暴露于非专门为此目的设计和保护的所有设备上。

买方有责任在操作此模型时确保安全防护措施。您负责此模型的组装和操作。请仔细阅读该手册，并始终随时随地以备参考。ONL Y使用Carisma / Carisma Racing零件来获得最佳性能，第三方零件的安装将立即使保修失效。不当的操作可能会导致人身或财产损失。

Carisma / Carisma Racing或我们的分销商对于运输，不正确的构造或不正确的方式造成的任何损坏不承担任何责任。SCA-1E 2.1 是一款高质量的1/10比例四轮驱动越野、履带式 and 比例履带车，推荐给14岁及以上的人使用。它不是玩具，而是一种精密的自建套件。在组装和操作过程中，始终需要成人监督。

如有疑问，请向您的RC狂热爱好者寻求建议或与local业余爱好商店或国家/地区分销商联系以寻求协助。我们会不断改进和开发我们的所有产品，因此，套件的确切规格可能会因批次而异，恕不另行通知。该产品包含加利福尼亚州已知的会导致癌症和出生缺陷或其他生殖伤害的化学物质。

Carisma Scale Adventure保证该模型套件在购买时不存在材料和工艺上的缺陷。在任何情况下，保修期内的总货币价值都不会超过所购买原始套件的成本。本保修不涵盖任何因使用、改装或磨损而损坏的组件。该套件中缺少的部分零件必须在购买后30天内报告。

在保修期内申请索赔时，必须始终发送购买证明。如果发现零件有缺陷或缺失，请与当地经销商联系。您的本地服务和客户支持将是您的第一联系点。始终从当地商店购买产品，以获得最佳的客户支持。



最新リリースをご購入いただきありがとうございます。ようこそ  
カリスмасケールアドベンチャーの成長し続ける世界へ！

SCA-1E 2.1 キットは、スケール愛好家のために、スケール愛好家によって設計されました。Itは、self-buildスケールシーンへの手頃な方法を提供し、エンドユーザーが自分の好みや能力に合わせてその仕上りの外観とパフォーマンスを調整できるようにします。必要に応じて、ビルドを詳細または単純に実行します。キットをあなた自身の個性の拡張にし、あなたが望むようにそれをパーソナライズしてください。冒険は、箱を開けた瞬間から始まり、スケールの詳細を追加し、実行し、リグをさらに変更するたびに続きます。

在庫を作り、トレイルを簡単に走り、より穏やかな形のロックローリングに乗り出し、非常に高性能であるだけでなく、非常に耐久性のあるリグを所有します。ボディのディテール、ホイールの重量測定、ショックの調整、最適な重量バイアスに最適なコンポーネントレイアウトの取得に時間を費やすと、DNAがRecon G6対応であるだけでなく、ストックRTRが完全にG6認定されていることが証明されたリグがあります。2017年に厳しい12時間のフィクスエンデュロ。そのオリジナルのデザインを採用し、キット用にさらに改良しました。

このキットは、CMS (Chassis Mounted Servo) を備えており、前方に取り付けられたバッテリートレイにより、重量バイアスを完全に最適化し、リグのクロール機能を向上させます。また、新しい真のビードロックホイールシステム、ソフトコンパウンドの全地形対応タイヤ、改良されたアッパーショックマウントとシャーシブレースも設計しました。SCA-1 Eは進化しましたが、価格は競争力があり、すべての人にとって手頃な価格です。SCA-1E 2.1は、標準のRCツールを使用して簡単に構築でき、ランニングや競技の合間にメンテナンスが簡単で、既存の多くのサードパーティスケールのパーツやアクセサリを使用して簡単に変更またはホップアップできます。Carisma Scale Adventureは、CNC合金と高性能プラスチックの両方で、さまざまな公式ホップアップとパフォーマンスパーツも製造しています。

専用のWebサイト (www.carismascaleadventure.com) で、チームドライバーからの最新情報、製品リリース、セットアップのヒントをすべて最新の状態に保ち、Facebook、Instagram、Twitter、TikTokでソーシャルになりましょう。

「SCA-1E 2.1の購入は冒険の始まりに過ぎません。冒険の始まりはあなた次第です...」

### 安全上のご注意

このモデルは、14歳以上の人のみ適しています。  
このラジコンモデルはおもちゃではありません。  
初心者は、モデルや部品を正しく組み立てて最高のパフォーマンスを発揮するために、経験豊富な人にアドバイスを求める必要があります。  
\*このモデルまたは部品は、子供の手の届かない場所のみ組み立て、安全な予防措置を講じてから操作してください。モデルの組み立てと安全な操作については、ユーザーが全責任を負います。

### 前書き

これは洗練されたホビー製品であり、おもちゃではありません。注意と常識を持って操作する必要があります。ユーザーはまた、いくつかの基本的な機械的能力を必要とします。この製品を安全かつ責任ある方法で操作しないと、怪我をしたり、製品やその他の特性に損傷を与える可能性があります。この製品は、大人の直接の監督なしに子供が使用することを意図したものではありません。製品manuaには、安全な操作とメンテナンスの手順が含まれています。正しく動作し、損傷や怪我を防ぐために、組み立て、セットアップ、または使用前に、マニュアルのすべての指示と警告を読み、それに従うことが不可欠です。

### 安全性、注意事項および警告

この製品のユーザーとして、あなたは自分自身や他人を危険にさらしたり、製品や他人の財産に損傷を与えたりしない方法でそれを操作する責任があります。このモデルは、制御できない多くのソースからの干渉を受けやすい無線信号によって制御されます。この干渉により、制御が一時的に失われる可能性があるため、衝突や怪我を防ぐのに役立つため、モデルの周囲のすべての方向で常に安全な距離を保つ必要があります。正しく動作し、損傷や怪我を避けるため。

- モデルは、車、交通、または人から離れたオープンエリアで常に操作してください。
- 怪我や損傷が発生する可能性のある路上でモデルを操作することは避けてください。
- いかなる理由であれ、モデルを通りや人口密集地に操作しないでください。
- 送信機の電池が少ない状態でモデルを操作しないでください。
- この製品および使用するオプションのサポート機器（充電器、充電式バッテリーパックなど）の指示と警告に注意深く従ってください。
- すべての化学薬品、小さな部品、および電気的なものはすべて、気のない場所に保管してください。
- 湿気は電子機器に損傷を与えます。この目的のために特別に設計および保護されていないすべての機器への水への暴露を避けてください。

このモデルを操作する際の安全上の注意を確実にするのは、購入者の責任です。このモデルの組み立てと操作は、お客様の責任で行ってください。罪状認否はマニュアルを完全に読み、参照のために常に手元に置いておいてください。ONL Yは、最大のパフォーマンスを得るためにカリスマ/カリスマレーシングパーツを使用しています。サードパーティの部品を取り付けると、すぐに保証が無効になります。不適切な操作は、人的または物的損害を引き起こす可能性があります。

カリスマ/カリスマレーシングまたは当社の販売代理店は、配送、不適切な構造、または不適切な結果によるいかなる損害についても責任を負いません。SCA-1E 2.1は、高品質の1/10スケール4WDオフロード、トレイル、スケールクローラーで、14歳以上

の方におすすめです。おもちゃではなく、精密なセルフビルドキットです。組み立ておよび操作中は、常に大人の監督が必要です。

疑わしい場合は、仲間のRC愛好家にアドバイスを求めるか、ロカホビショップまたは国の販売代理店に連絡して支援を求めてください。当社は常にすべての製品を改善および開発しているため、キットの正確な仕様は事前の通知なしにバッチごとに変更される場合があります。この製品には、カリフォルニア州で癌や先天性欠損症、またはその他の生殖障害を引き起こすことが知られている化学物質が含まれています。

カリスмасケールアドベンチャーは、このモデルキットが購入時に材料と製造の両方に欠陥がないことを保証します。保証期間中の合計金額は、いかなる場合でも、購入した元のキットのコストを超えることはありません。この保証は、使用、変更、または摩耗によって損傷したコンポーネントには適用されません。このキットに欠けている部品の一部は、購入から30日以内に報告する必要があります。

保証期間中の請求を申請する場合は、購入証明書を常に送付する必要があります。欠陥のある部品や不足している部品を見つけた場合は、最寄りの販売店にお問い合わせください。ローカルサービスとカスタマーサポートが最初の連絡先になります。あなたが最高のカスタマーサポートを得ることができるあなたの地元の店から常に購入してください。



Vielen Dank für den Kauf unserer neuesten Version und willkommen in der stetig wachsenden Welt von Carisma Maßstabs-Abenteurer!

Das SCA-1E 2.1 Kit wurde von Maßstabsenthusiasten für Maßstabsliebhaber entwickelt. Es bietet einen erschwinglichen Weg in die Eigenbau-Maßstabs-Szene und ermöglicht es dem Endanwender, das finale Aussehen und die Leistung an seinen eigenen Geschmack und seine Fähigkeiten anzupassen. Verfolgen Sie den Bau so detailliert oder so einfach wie Sie es wollen. Machen Sie den Bausatz zu einer Erweiterung Ihrer Persönlichkeit und personalisieren Sie es nach Belieben. Das Abenteuer beginnt in dem Moment in dem Sie die Box öffnen, und wird jedes Mal fortgesetzt, wenn Sie maßstabsgetreue Details hinzufügen, das Fahrzeug benutzen, oder es weiter modifizieren.

Bau es Original und fahre Wege mit Leichtigkeit, begib dich auf mildere Felssteigungen und besitze ein Fahrzeug das nicht nur sehr leistungsfähig, sondern auch extrem robust ist. Oberprüfe die Karosserie, setze das Gewicht der Räder, stelle die Dampfer ein und verbringe deine Zeit damit, das richtige Teile-Aufbau für die optimale Gewichtsverteilung zu finden. Du hast ein Gefährt, dessen DNA nachweislich nicht nur Recon G6-fähig ist, sondern auch im Jahr 2017 über eine anstrengende 12 Stunden Fix Enduro G6 zertifiziert wurde. Wir haben das ursprüngliche Design übernommen und es für den Bausatz weiter verbessert.

Der Bausatz verfügt über eine CMS (Chassis Mounted Servo - Karosseriemontierte Servolenkung) mit einem vorne montierten Batteriefach, um die Gewichtsverteilung vollständig zu optimieren und die Crawling-Fähigkeiten des Gefährts zu verbessern. Wir haben außerdem ein neues verschraubtes Radsystem entwickelt, mit weichen All Terrain-Reifen und verbesserten oberen Stoßdämpferhalterungen und Chassisverstreben. Der SCA-1E 2.1 hat sich weiterentwickelt, aber der Preis ist weiterhin wettbewerbsfähig und für alle erschwinglich geblieben.

Der SCA-1E 2.1 lässt sich einfach mit Standard-RC-Werkzeugen bauen, ist leicht zwischen den Läufen oder Wettkämpfen zu warten und kann mit vielen vorhandenen Komponenten und Zubehörteilen von Drittanbietern leicht modifiziert oder erweitert werden. Carisma Scale Adventure produziert auch eine Reihe von offiziellen Erweiterungen und Performance-Teilen in CNC-Legierungen und Hochleistungskunststoffen.

Blieben Sie mit den neuesten Informationen, Produktveröffentlichungen und Setup-Tipps von unseren Teamfahrern auf unserer gewidmeten Webseite ([www.carismascaleadventure.com](http://www.carismascaleadventure.com)) auf dem laufenden und interagieren Sie mit uns auf Facebook, Instagram und Twitter.

„Der Kauf deines SCA-1E 2.1 ist nur der Anfang des Abenteuers, wo es dich schließlich hinführt, ist deine eigene Wahl...“

## Sicherheitsvorkehrungen

DIESES MODELL IST NUR FÜR PERSONEN AB 14 JAHREN GEEIGNET.  
DIESES FUNKKONTROLLMODELL IST KEIN SPIELZEUG.

Anfänger sollten sich von erfahrenen Personen beraten lassen, um das Modell oder die Teile richtig zusammenzusetzen und die beste Leistung zu erhalten.  
\*Montieren Sie dieses Modell oder Teile nur außerhalb der Reichweite von Kindern und treffen Sie vor dem Betrieb dieses Modells Vorsichtsmaßnahmen. Der Benutzer ist komplett für die Modellmontage und den sicheren Betrieb verantwortlich.

## Einführung

Dies ist ein anspruchsvolles Hobbyprodukt und kein Spielzeug. Es muss mit Vorsicht und gesundem Menschenverstand betrieben werden. Der Benutzer benötigt auch einige grundlegende mechanische Fähigkeiten.  
Wenn dieses Produkt nicht sicher und verantwortungsbewusst betrieben wird, kann dies zu Verletzungen, Schäden am Produkt oder anderem Eigentum führen.  
Dieses Produkt ist nicht für die Verwendung von Kindern ohne direkte Aufsicht von Erwachsenen vorgesehen. Das Produkthandbuch enthält Sicherheitshinweise für den Betrieb und Instandhaltung.  
Bevor Sie mit der Montage, Vorbereitung oder Benutzung beginnen, ist es notwendig, alle Anweisungen und Warnungen in diesem Handbuch zu lesen, um das Fahrzeug richtig zu betreiben und Schäden oder Verletzungen zu vermeiden.

## Sicherheit, Vorsichtsmaßnahmen und Warnungen

Als Benutzer dieses Produkts sind Sie allein dafür verantwortlich, das Sie es auf eine Art und Weise betreiben, sich nicht selbst oder andere zu gefährden, oder Schaden am Produkt oder Eigentum zu verursachen.  
Dieses Modell wird von einem Funksignal gesteuert, das von vielen Quellen außerhalb Ihrer Kontrolle gestört werden kann. Diese Störung kann zu einem vorübergehenden Verlust der Kontrolle führen, daher ist es notwendig, immer einen Sicherheitsabstand in alle Richtungen um Ihr Modell herum einzuhalten. Dies hilft dabei, Kollisionen oder Verletzungen zu vermeiden.

- Betreiben Sie Ihr Modell immer in einem offenen Bereich abseits von Autos, Verkehr oder Personen.
- Vermeiden Sie den Betrieb Ihres Modells auf der Straße, wo Verletzungen oder Schäden auftreten können.
- Betreiben Sie das Modell niemals aus irgendeinem Grund auf der Straße oder in bewohnten Gebieten.
- Betreiben Sie Ihr Modell niemals mit niedrig geladenen Senderbatterien.
- Befolgen Sie sorgfältig die Anweisungen und Warnhinweise zu diesem Produkt und allen optionalen Hilfsgeräten die Sie verwenden (Ladegeräte, wiederaufladbare Akkupackungen usw.).
- Bewahren Sie Chemikalien, Kleinteile und alle elektrischen Teile außerhalb der Reichweite von Kindern auf.
- Feuchtigkeit verursacht Schäden an der Elektronik. Vermeiden Sie, das Gerät Wasser ausgesetzt werden, die nicht speziell für diesen Zweck ausgelegt und geschützt sind.

Es liegt in der Verantwortung des Käufers, Sicherheitsvorkehrungen beim Betrieb dieses Modells zu treffen. Sie sind verantwortlich für die Montage und Operationen dieses Modells. Bitte lesen Sie das Handbuch sorgfältig durch und bewahren Sie es jederzeit als Referenz auf. Benutzen Sie NUR Carisma/Carisma Racing Teile für maximale Leistung. Die Installation von Teilen von Drittanbietern führt sofort zum Erlöschen der Garantie. Falschbedienung kann Personen- oder Sachschaden verursachen.  
Carisma/Carisma Racing oder unsere Händler sind NICHT verantwortlich für Schäden die durch den Versand, unangemessene Konstruktion oder unsachgemäße Verwendung entstehen. Durch das Öffnen der Schachtel akzeptiert der Käufer alle entstehenden Verpflichtungen. Für den Fall dass der Käufer NICHT bereit ist, diese Haftung zu übernehmen, OFFNEN SIE BITTE NICHT DIE SCHACHTEL und bringen Sie diesen Bausatz in neuem, unmontiertem und unbenutztem Zustand zurück zum Kauf.

Der SCA-1E 2.1 ist ein Allrad-, Trail- und Maßstabs-Crawler im Maßstab 1:10, der für Personen ab 14 Jahren und älter empfohlen wird. Es ist KEIN SPIELZEUG, es ist ein Präzisions-Eigenbau-Bausatz. Während der Montage und des Betriebs ist jederzeit eine Aufsicht durch einen Erwachsenen erforderlich.  
Im Zweifelsfall bitten Sie einen Ihrer RC-Enthusiasten um Rat, oder wenden Sie sich an Ihren örtlichen Händler oder an den Landervertrieb.  
Wir verbessern und entwickeln ständig alle unsere Produkte weiter, und daher können sich die genauen Spezifikationen des Bausatzes ohne vorherige Ankündigung ändern.

Dieses Produkt enthält eine Chemikalie, die dem Staat Kalifornien/USA bekannt ist Krebs, Geburtsfehler oder andere reproduktive Schäden zu verursachen.

Carisma Scale Adventure garantiert, dass dieses Modell beim Kauf frei von Defekten in Material und Verarbeitung ist. Der gesamte monetäre Wert unter Garantie wird auf KEINEN Fall die Kosten des ursprünglich gekauften Bausatzes übersteigen. Diese Garantie gilt nicht für Komponenten die durch Gebrauch, Änderungen oder Verschleiß beschädigt wurden. Ein fehlendes Teil oder Teile dieses Bausatzes muss innerhalb von 30 Tagen nach dem Kauf gemeldet werden.

Der Kaufbeleg muss bei der Beantragung eines Gewährleistungsanspruchs jederzeit zugesendet werden. Sollten Sie ein beschädigtes oder fehlendes Teil feststellen, wenden Sie sich bitte an Ihren lokalen Händler. Ihr lokaler Dienstleister und Kundenbetreuung wird Ihre erste Anlaufstelle sein. Kaufen Sie immer von Ihrem lokalen Händler, wo Sie die beste Kundenbetreuung erhalten können.

Grazie per aver acquistato il nostro ultimo prodotto e benvenuti nel sempre più vasto mondo Carisma Scale Adventure!

Il kit SCA-1E 2.1 è stato progettato da appassionati di modellismo per gli appassionati di modellismo. È il mezzo ideale per entrare nel mondo del modellismo "fai-da-te" e consente all'utente di personalizzare l'aspetto e le prestazioni del proprio modello in base al proprio gusto e alle proprie capacità, combinando semplicità e dettaglio. Questo kit potrà diventare un'estensione della vostra personalità perché potrete personalizzarlo come vorrete. L'avventura comincia nel momento in cui aprite la scatola e continuerà ogni volta che aggiungerete un dettaglio, che modificherete o che guiderete il vostro modello.

Con i componenti di serie sarà già capace di percorrere qualsiasi tracciato con facilità, sarà un discreto scalatore e scoprirete che non è solo performante, ma anche molto affidabile. Dettagliate la carrozzeria, zavorrate le gomme, settate gli ammortizzatori, bilanciate bene il peso e avrete lo stesso modello che ha dimostrato di essere più che semplicemente adatto alle mitiche gare G6; nel 2017, infatti, si è guadagnato la Certificazione G6 dopo la estenuante 12 ore Fix Enduro. Abbiamo voluto lavorare sul progetto originale per migliorarlo ancora e ottenere, con il nuovo modello, proprio questi risultati.

Il kit sfoggia un sistema CMS (servo montato direttamente sul telaio) e un supporto batteria avanzato per ottimizzare il bilanciamento del peso e migliorare le capacità di scalata. Abbiamo anche disegnato un nuovo sistema beadlock per bloccare gli pneumatici, montato nuove gomme a mescola morbida adatte a tutti i terreni e migliorato i montanti superiori delle sospensioni e i bracci del telaio. SCA-1E 2.1 si è evoluto, ma il prezzo è rimasto competitivo e abbordabile.

SCA-1E 2.1 si monta facilmente con i più comuni e diffusi attrezzi RC, la sua manutenzione è molto semplice e lo si può modificare e migliorare con tutti i componenti e gli accessori di terze parti già esistenti in commercio. Carisma Scale Adventure produce anche tutta una serie di pezzi opzionali e speciali in plastiche ad alte prestazioni e alluminio CNC.

Tenetevi aggiornati su tutte le ultime informazioni, i nuovi prodotti e i consigli per la messa a punto del nostro team di piloti, consultando il nostro sito web dedicato [www.carismascaleadventure.com](http://www.carismascaleadventure.com) e contattandoci sui social: Facebook, Instagram e Twitter.

„Aver comprato SCA-1E 2.1 è solo l'inizio dell'avventura, dove vi porterà dipende solo da voi...“  
Kit Scalatore 4WD 1 :10

## Misure di sicurezza

QUESTO MODELLO È UTILIZZABILE SOLO DA PERSONE DI 14 ANNI O PIÙ.  
QUESTO MODELLO RADIOCOMANDATO NON È UN GIOCATTOLO.

I principianti dovrebbero seguire i consigli di utenti esperti per montare correttamente il modello e ottenere le migliori prestazioni.

\*Montate questo modello e le sue parti solo fuori dalla portata dei bambini e prendete tutte le precauzioni possibili prima di usarlo. L'utente è pienamente responsabile del montaggio di questo modello e del suo utilizzo in sicurezza.

## Introduzione

Questo è un prodotto da modellismo e non un giocattolo. Deve essere utilizzato sempre con cautela e buon senso. L'utilizzatore deve possedere una minima esperienza di meccanica di base.

Il mancato utilizzo del prodotto in maniera responsabile e sicura può causare danni al prodotto stesso, a cose o a persone.  
Questo prodotto non è adatto all'utilizzo da parte di bambini senza il controllo diretto e la supervisione degli adulti. Il manuale del prodotto contiene tutte le istruzioni per un utilizzo sicuro e per la manutenzione.

È indispensabile leggere e seguire tutte le istruzioni e le avvertenze del manuale prima di montare, regolare o usare il prodotto, per evitare danni a cose o a persone.

## Sicurezza, precauzioni e avvertimenti

Come utilizzatori di questo prodotto sarete i soli responsabili del suo corretto utilizzo, facendo in modo che non metta in pericolo la vostra incolumità o quella degli altri o che possa arrecare danno al prodotto o a proprietà di terzi.

Questo modello è controllato da un segnale radio che può essere soggetto a interferenze causate da numerose sorgenti fuori dal vostro controllo. Queste interferenze possono causare la momentanea perdita di controllo del modello, quindi è necessario rispettare sempre una ragionevole distanza di sicurezza in tutte le direzioni per evitare collisioni o ferimenti.

- Usate sempre il vostro modello in un'area aperta, lontano da macchine, traffico o persone.
- Evitate di usare il modello per strada, dove è possibile causare danni a cose o persone.
- Non usate mai il modello su strade o aree popolate, per nessuna ragione.
- Non usate mai il modello con le batterie della trasmittente scariche.
- Seguite attentamente le indicazioni del prodotto e quelle di tutti gli accessori opzionali (caricatore, batterie, eccetera) che usate.
- Tenete lontani dalla portata dei bambini tutti i componenti più piccoli, le parti elettriche e le sostanze chimiche.
- L'umidità può danneggiare l'elettronica. Evitate l'esposizione all'acqua di tutti i componenti non specificatamente progettati e protetti per questo scopo.

È responsabilità dell'acquirente rispettare tutte le precauzioni di sicurezza nell'utilizzo del modello. Siete responsabili del montaggio e della sua operatività. Leggere il manuale attentamente e tenetelo sempre a portata di mano come riferimento. Usate SOLO ricambi Carisma/Carisma Racing per garantire sempre le massime prestazioni. L'utilizzo di componenti di terze parti invalida immediatamente la garanzia. L'utilizzo improprio del modello può causare danni a persone o a cose. Carisma/Carisma Racing e i suoi distributori NON sono responsabili per eventuali danni causati dal trasporto, dal montaggio scorretto o dall'uso improprio del prodotto. Apprendo la confezione l'acquistatore accetta automaticamente e accetta insieme a tutte le responsabilità connesse. Nel caso l'acquirente non sia disposto ad accettare queste responsabilità si prega di NON APRIRE LA SCATOLA e restituire il kit al rivenditore, in condizioni pari al nuovo, non montato e mai usato.

Lo SCA-1E 2.1 è un modello di Crawler fuoristrada 4WD in scala 1:10 di alta qualità, raccomandato per persone con minimo 14 anni di età. NON È UN GIOCATTOLO, è un kit di montaggio di alta precisione. La supervisione di un adulto è richiesta per tutte le fasi di assemblaggio e di utilizzo.

In caso di dubbi chiedete consiglio ai vostri amici esperti modellisti o contattate il vostro negozio di fiducia o il distributore nazionale per ricevere assistenza.

Sviluppiamo e miglioriamo costantemente tutti i nostri prodotti, pertanto le specifiche possono subire delle variazioni senza preavviso.

Questo prodotto contiene sostanze chimiche ritenute causa di tumori, di difetti alla nascita o altri effetti dannosi per il sistema riproduttivo dallo Stato della California.

Carisma Scale Adventure garantisce che questo modello, al momento dell'acquisto, è privo di difetti relativi ai materiali o alla fabbricazione. Il rimborso totale sotto garanzia NON POTRÀ: in nessun caso, essere superiore al costo d'acquisto del kit originale. Questa garanzia non copre nessun danno causato dall'uso, da modifiche o da usura. Eventuali pezzi mancanti dalla scatola originale devono essere segnalati entro 30 giorni dall'acquisto.

La prova d'acquisto deve essere sempre spedita in caso di reclamo sotto garanzia. Se dovete trovare parli difettose o mancanti contattate il distributore locale. L'assistenza locale e il supporto clienti saranno il vostro primo punto di contatto. Acquistate sempre nei negozi locali per assicurarvi la migliore assistenza.



**Study the instructions thoroughle before assembly**

There are many small screws, nuts and similar parts. Please refer to the column on the left to know the exact size. To prevent trouble and finish the model correctly offering optimum performance, it is necessary to assemble each step exactly as shown.

**Items Required for Completion**



**TRANSMITTER**

**CTX8000 2.4GHZ DIGITAL FHSS**

The incredible Radio system is a feature packed, economically priced, product to suit all types of RC driving needs. The CTX8000 includes functions such as ATV (for adjusting the maximum steering angle on both sides when the model is turning), an FTN Key (used to synchronise the connection between the transmitter and receiver, also serving as an optional function on some models), LED indicator (for battery low, programming status indicator, etc), plus trim functions on steering on throttle.



Part No:  
**15644**



**ELECTRONIC SPEED CONTROLER**

**ARC-2 Brushed ESC**

Suitable for both On and Off Road use, the new easy to set up and program ARC-2 is just at home bashing in a fun RTR, as it is running Trails, Rock Crawling or fighting for pole position in a Stock Racing class at the local RC Club. It's the perfect upgrade to the stock units many RC Vehicles ship with, or as an affordable and versatile Brushed ESC in a custom build. The included MPG-1 Programming card makes fast mode and parameter changes possible while out on the trails or track side.



Part No:  
**16115**



**MOTOR**

**17T 5-Pole Brushed Motor**

Our own Crawler Specific, High Torque Brushed Motor. Designed to offer the ultimate balance between RPM for Trail Running and Low End throttle finesse for Rock Crawling.



Part No:  
**16276**



**SERVO**

**6kg High Torque Steering Servo**

Metal Geared for Durability and offering 9kg of Torque at 6v as standard. The CSA stock Steering Servo is versatile enough to be fitted to a variety of different vehicles.



Part No:  
**15942**



**BATTERY PACK**

**7.2v 1400 MAH NiMH Stick Pack**

A safe and trusted method of powering any genre of RC vehicle. NiMH packs offer a long lifespan of charge cycles, and can easily be stored ready for future use without affecting their performance.



Part No:  
**15927**

These items are available on Carisma Online Shop: [www.carisma-shop.com](http://www.carisma-shop.com)

**Recommended Tools**

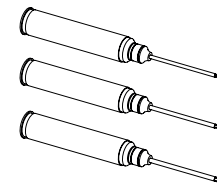

Hex Wrenches (1.5, 2.0, 2.5mm)

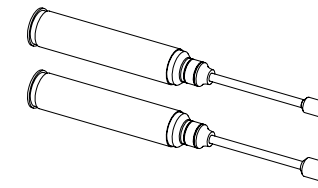

Nut Drivers (5.5, 7.0mm)

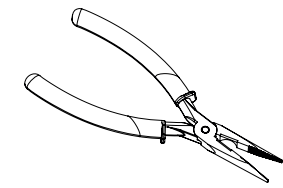

Pliers



ThreadLock



Silicone Shock Oil

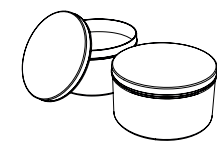

Grease

**Icon description**

|                               |   |                       |                       |
|-------------------------------|---|-----------------------|-----------------------|
| Special Attention is Required | Assemble Left & Right side the same way | Real size of the part | Assembly two times    |
| Apply Thread-lock             | Apply Grease                            | Apply Oil             | Complete sub assembly |

**CE Compliance Information For The European Union**

The associated regulatory agencies of the following countries recognize the noted certifications for this product as authorized for sale and use.

|    |    |    |    |    |    |    |    |    |    |    |    |    |
|----|----|----|----|----|----|----|----|----|----|----|----|----|
| UK | DE | DK | BG | SE | CZ | ES | NL | SK | HU | RO | FR | PT |
| FI | EE | LV | LT | PL | AT | CY | SI | GR | MT | IT | IE | LU |

**Table of Contents**

|  |    |
|--|----|
| Shock Assembly - Bag A .....                   | 10 |
| Differential Assembly - Bag B .....            | 11 |
| Modular Axle Assembly - Bag C .....            | 12 |
| Front Shaft Assembly - Bag D .....             | 14 |
| Front Axle Assembly - Bag D .....              | 15 |
| Rear Axle Assembly - Bag E .....               | 16 |
| Suspension Links Assembly - Bag F .....        | 17 |
| Driveshaft Assembly - Bag G .....              | 18 |
| Gearbox Assembly - Bag H .....                 | 18 |
| Chassis Assembly- Bag I .....                  | 22 |
| Bumpers Assembly - Bag J .....                 | 26 |
| Beadlock Wheel and Tyre Assembly - Bag K ..... | 28 |
| Body Assembly - Bag L .....                    | 29 |
| Final Assembly - Bag M .....                   | 31 |

# A STEP 1 - 4

## Shock Assembly

BAG A / BEUTEL A  
SAC A /



**1**

**4x**

**2**

**4x**

The 'O' Ring Sits Inside Pre Load Collar and offers resistance to keep collar in place not tight.

! All shock parts under number: 15828

**3**

! Tighten the cap after inserting the shaft

**4x**

1:1

32.5 mm

**4**

**4x**

1. Pull the shaft down.
2. Fill it up with oil (30 WT Standard).
3. Move piston up and down few times.
4. Pull the shaft down.
5. Wait until air is release.
6. Move piston up.
7. Install top cap, let the oil leftovers flow out.

## Shock Assembly

# A STEP 5 - 6

BAG A / BEUTEL A  
SAC A /

**5**

**4x**

**6**

**4x**

SHOCK

## Differential Assembly

# B STEP 1 - 2

BAG B / BEUTEL B  
SAC B /

**1**

Button Head Screw M2 x 10mm

Bearing 10x15x4 15857

16024

15823

15821

15822

15857

**2x**

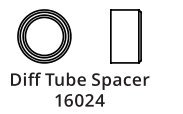
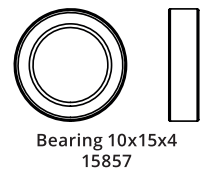

**2**

LOCKED DIFFERENTIAL

**2x**



**STEP 1 - 3**  
BAG C / BEUTEL C  
SAC C /

**Modular Axle Assembly**

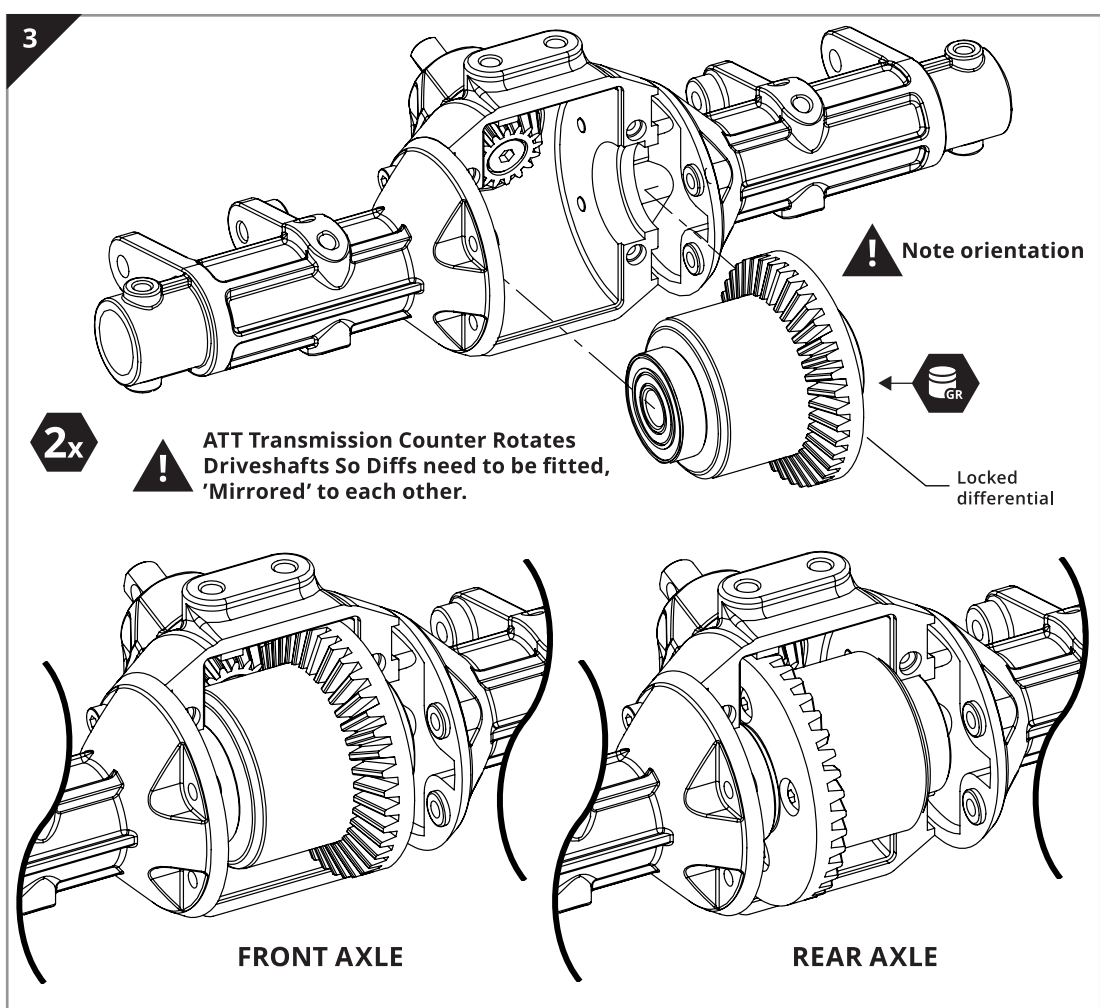
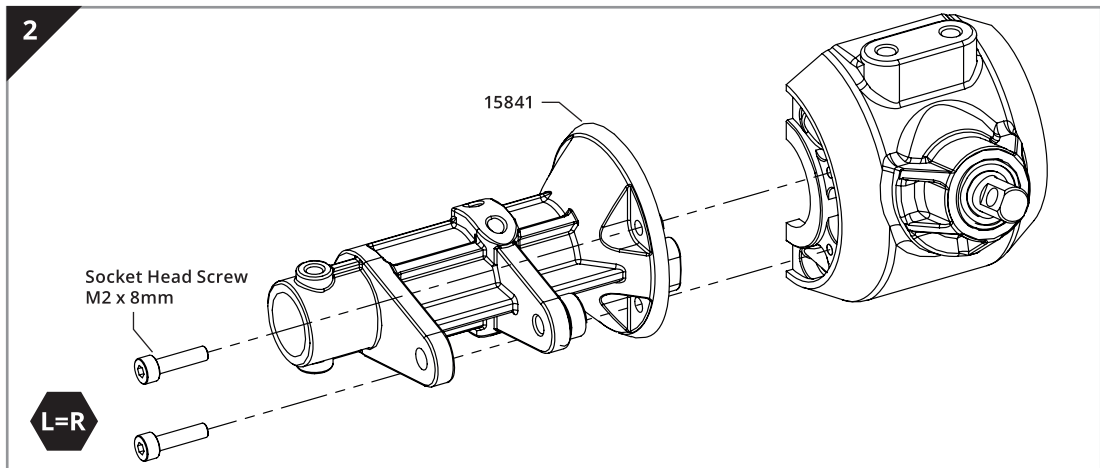
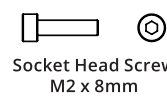
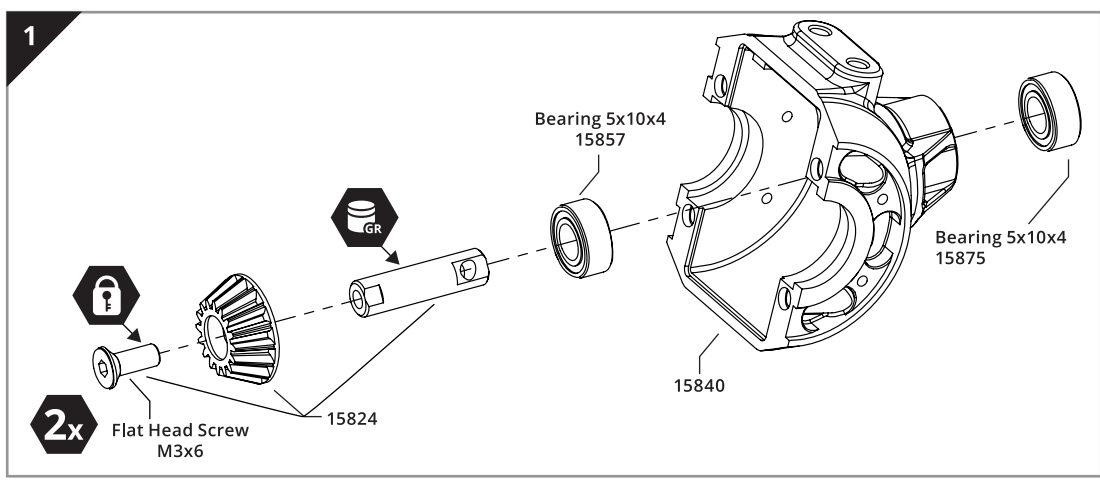
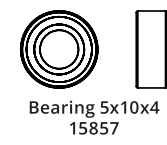
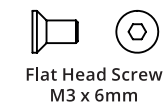

**Modular Axle Assembly**

**STEP 4 - 6**  
BAG C / BEUTEL C  
SAC C /

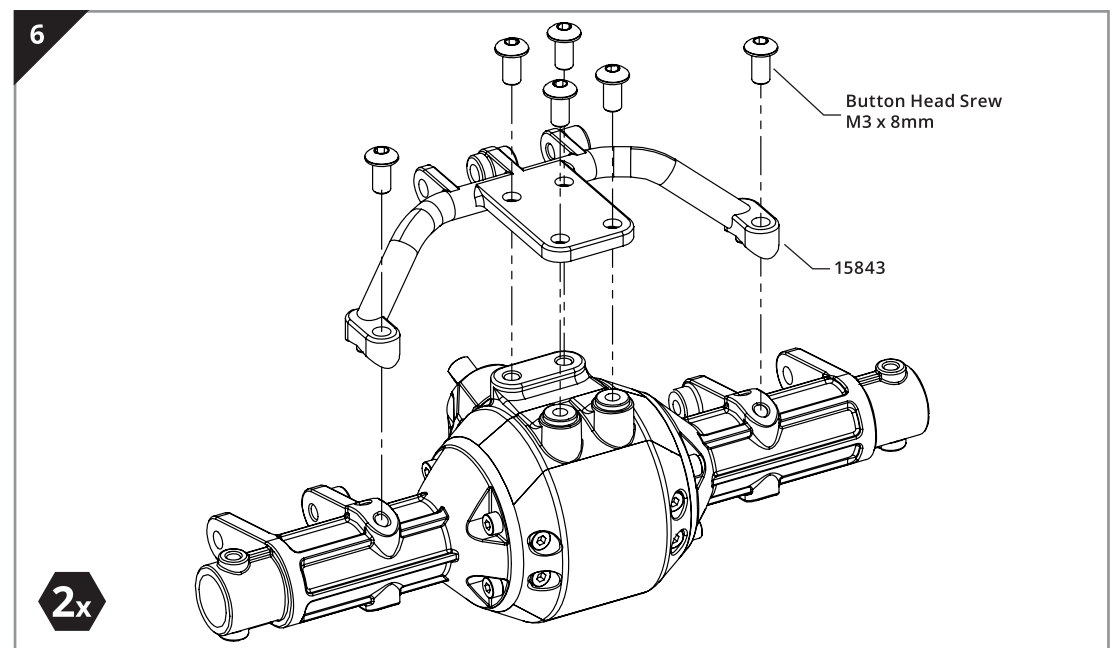
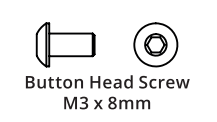
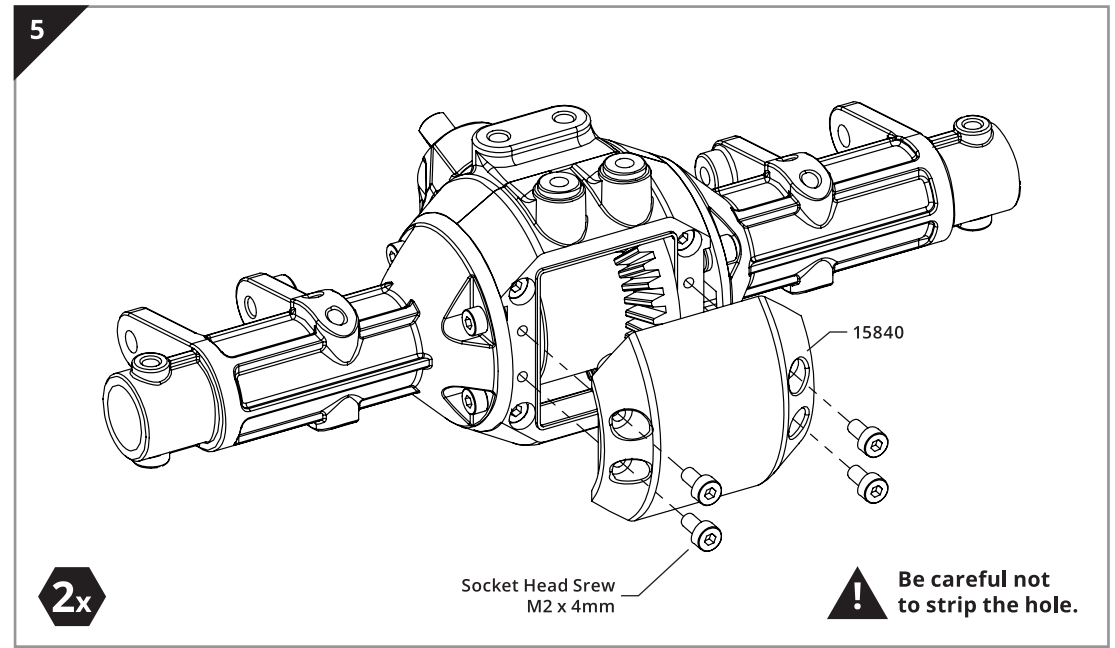
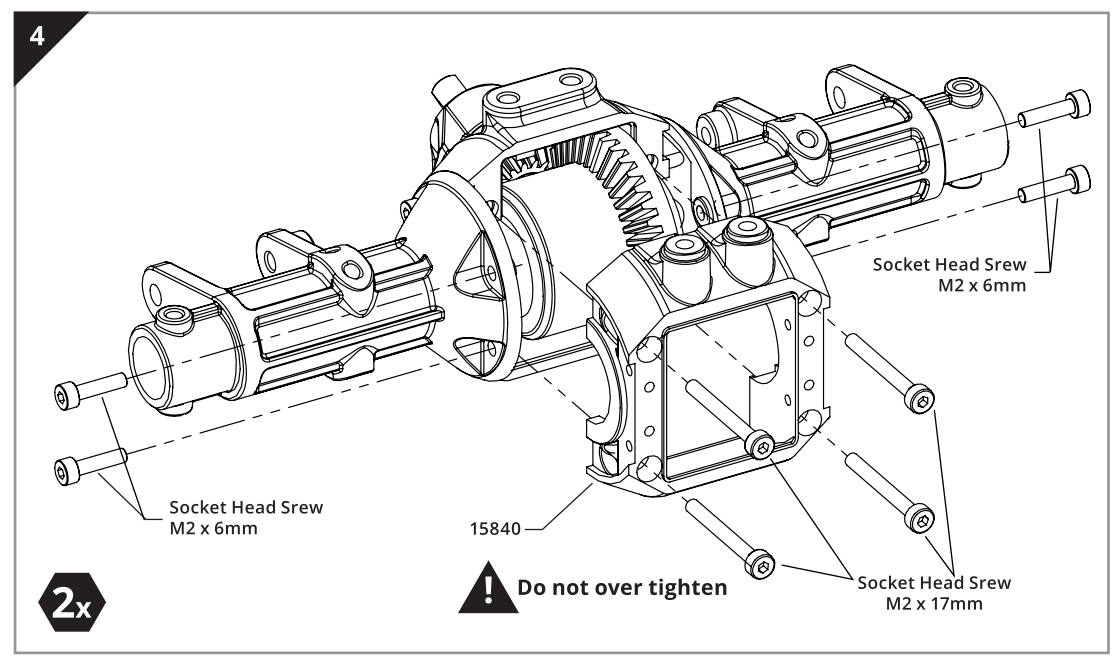
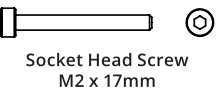
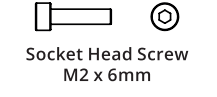

**D** STEP 1 - 3  
BAG D / BEUTEL D  
SAC D /

Front Shaft Assembly

Pin 2 x 10.8 mm  
15863

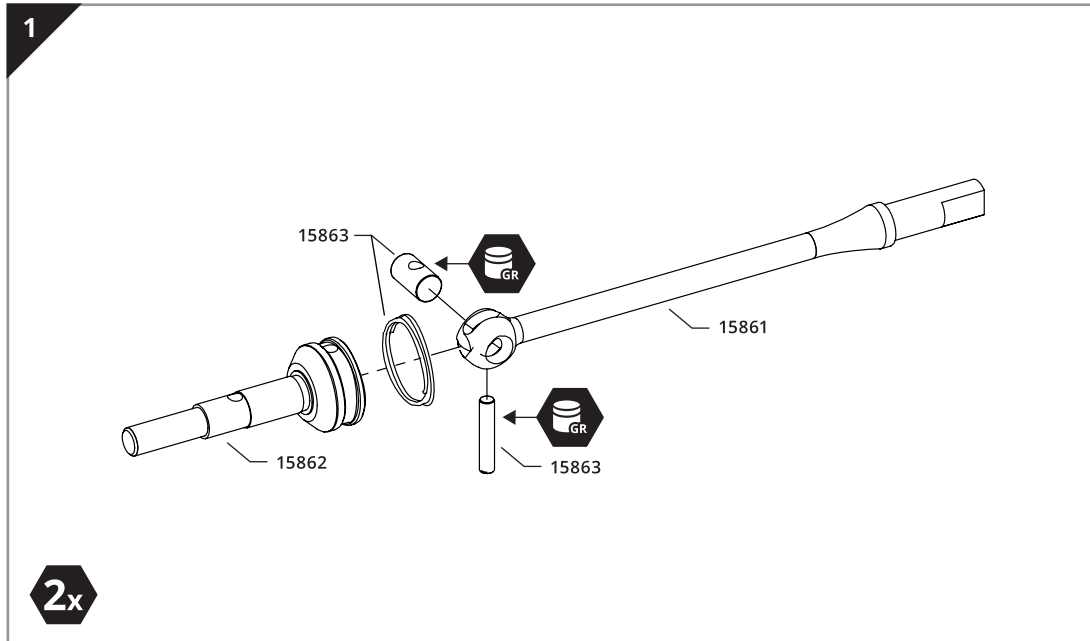

Pin 2 x 9.8  
15854

Bearing 5x10x4  
15857

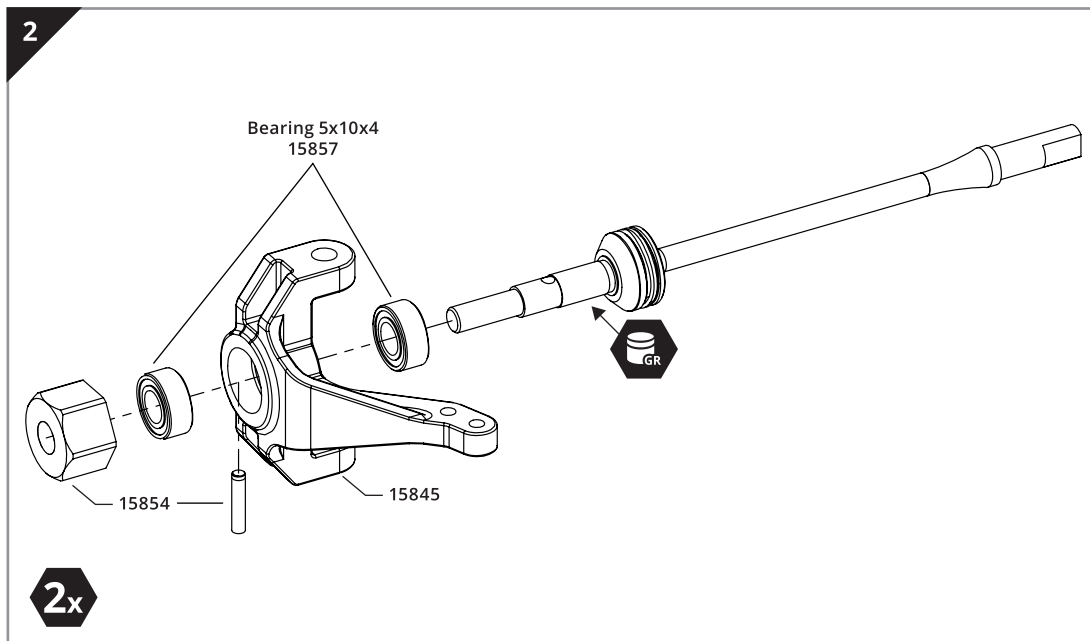

Shoulder Bolt  
15844

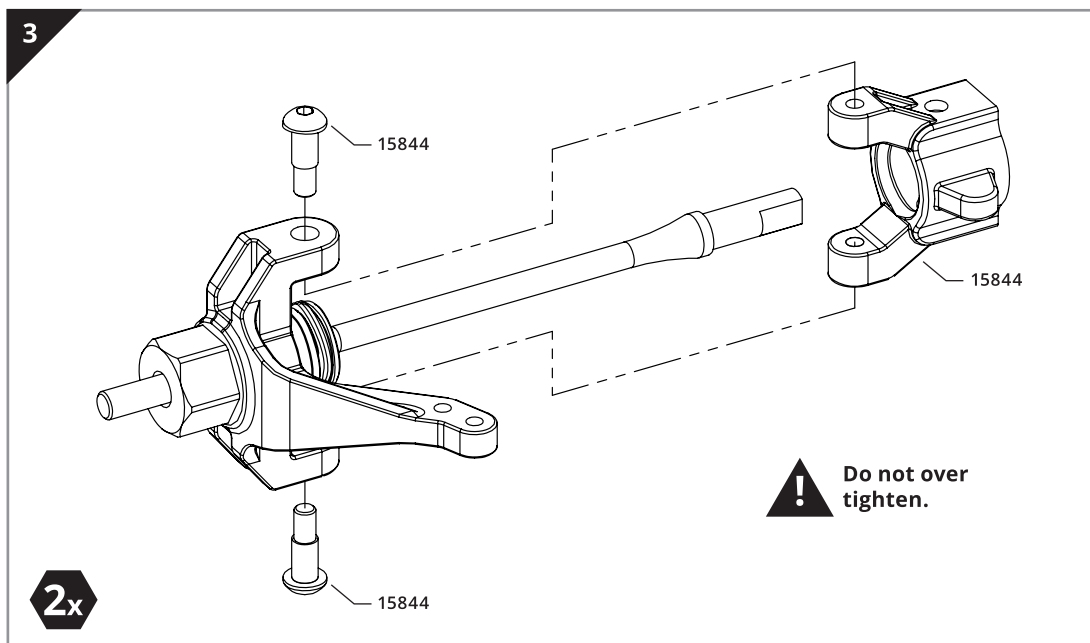

Front Axle Assembly

**D** STEP 4 - 6  
BAG D / BEUTEL D  
SAC D /

Button Head Screw  
M3 x 6mm

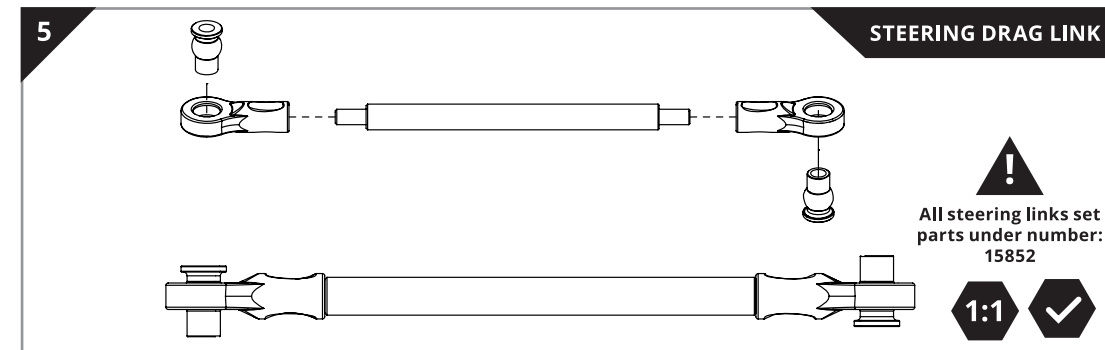
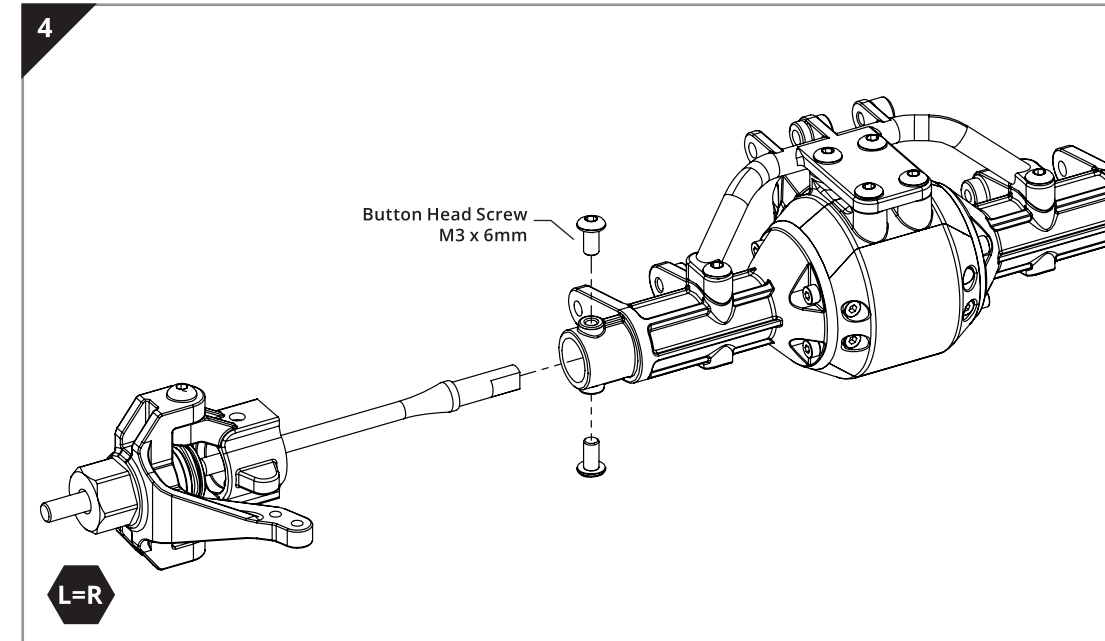

5.8 Extend  
Ball Link

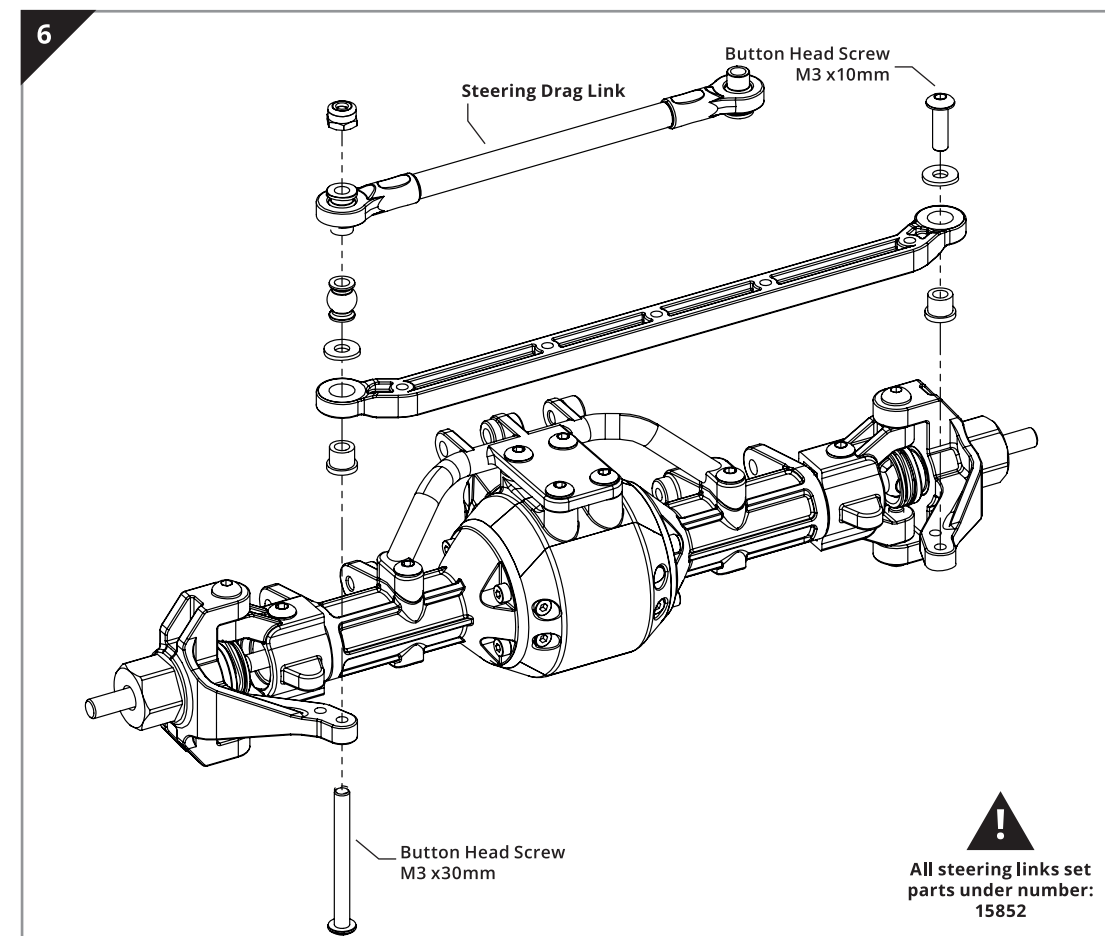

Button Head Screw  
M3 x 30mm

Button Head Screw  
M3 x 10mm

Washer 3x7x0.8

Bushing

5.8 Ball Link



**D** STEP 6 - 6  
BAG D / BEUTEL D  
SAC D /

Front Axle Assembly

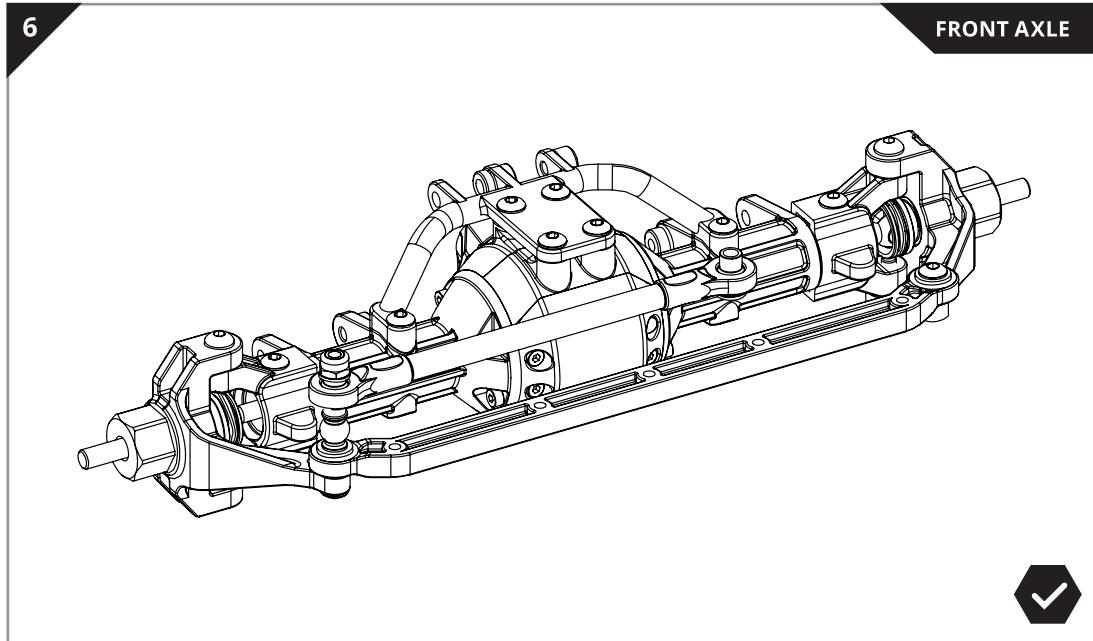

**E** STEP 1 - 2  
BAG E / BEUTEL E  
SAC E /

Rear Axle Assembly

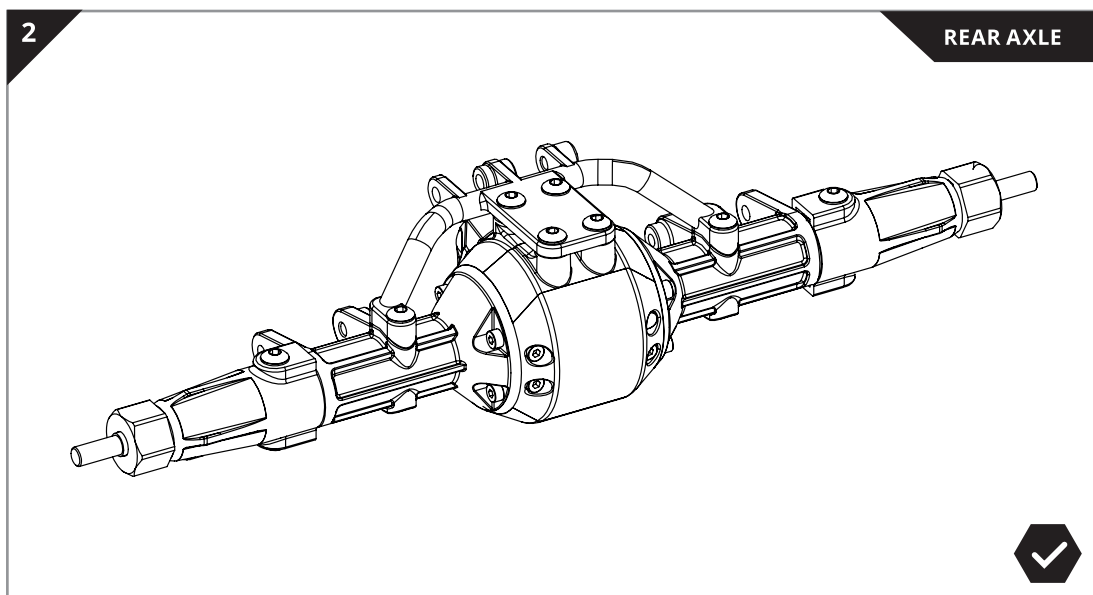
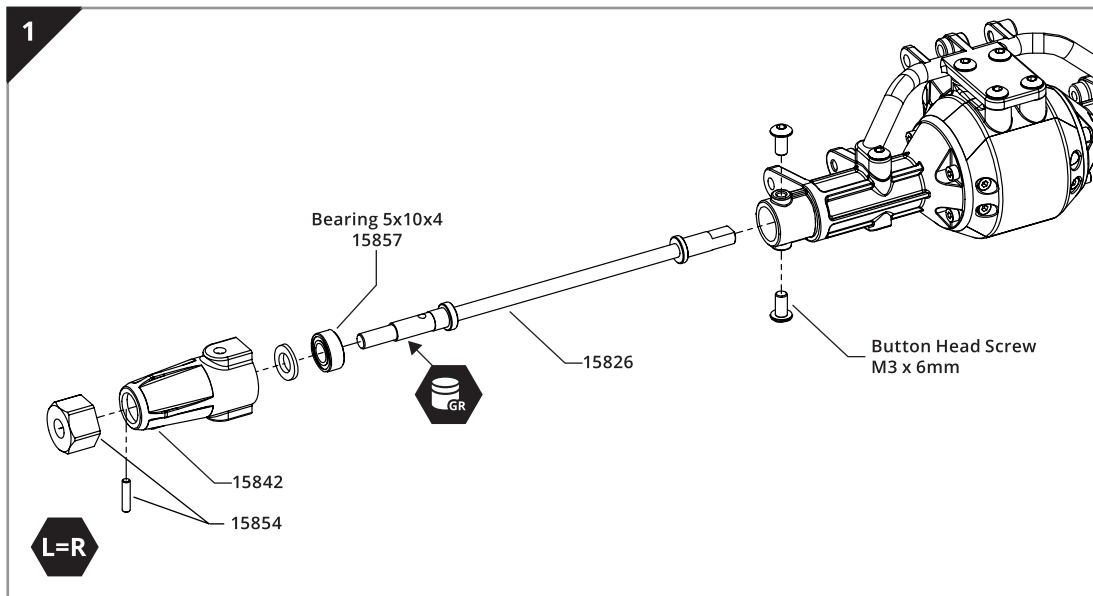
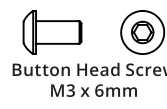
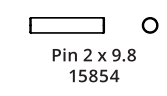
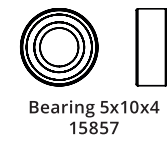

Suspension Links Assembly

**F** STEP 1 - 4  
BAG F / BEUTEL F  
SAC F /

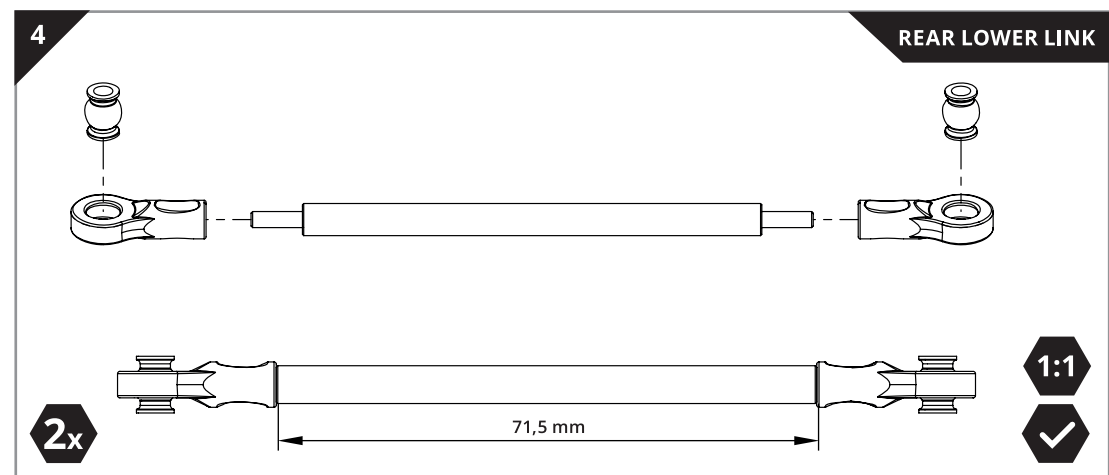
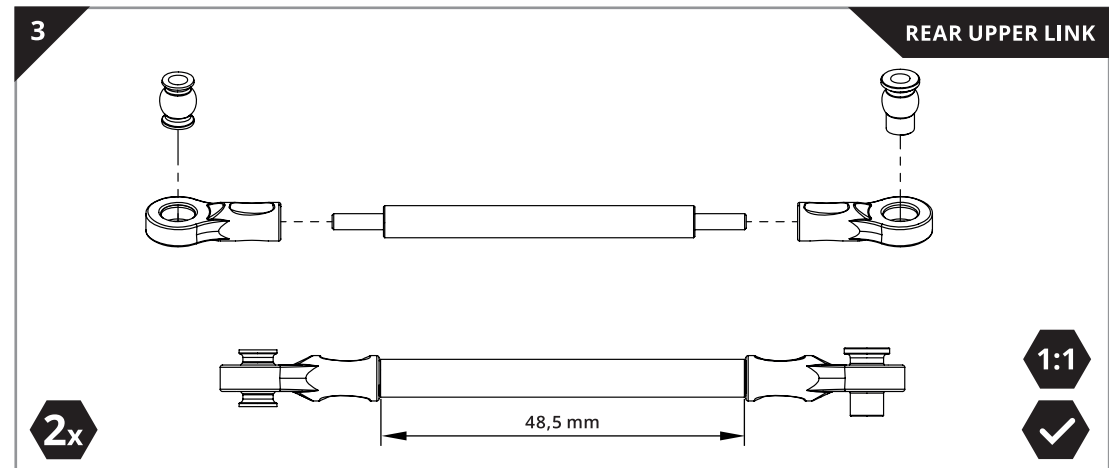
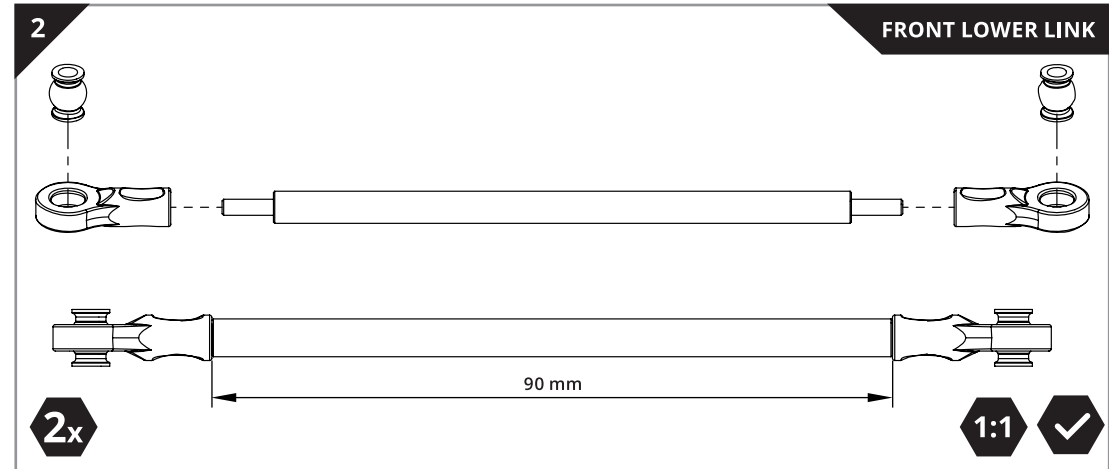
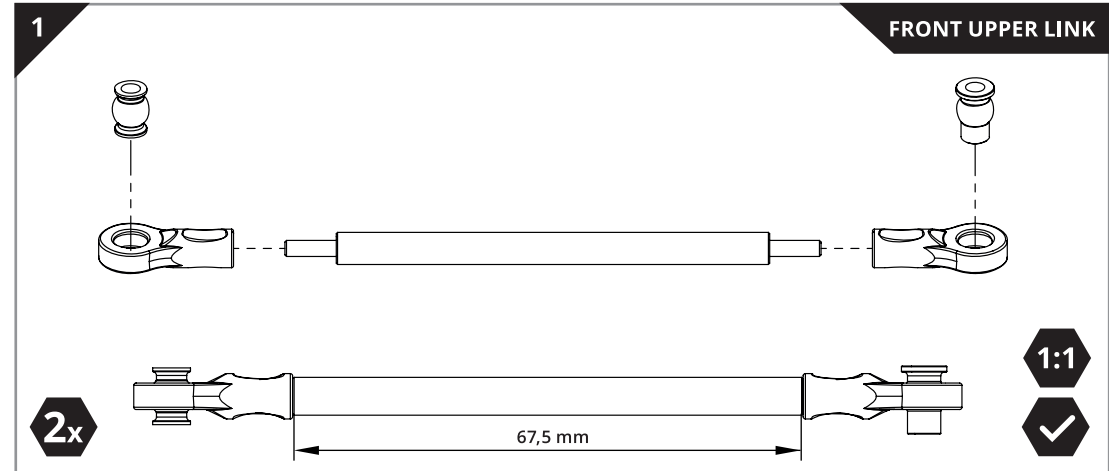
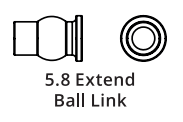
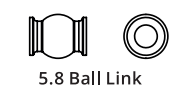

! All links parts under number: 15852



# G STEP 1

BAG G / BEUTEL G  
SAC G /

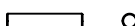
## Driveshaft Assembly



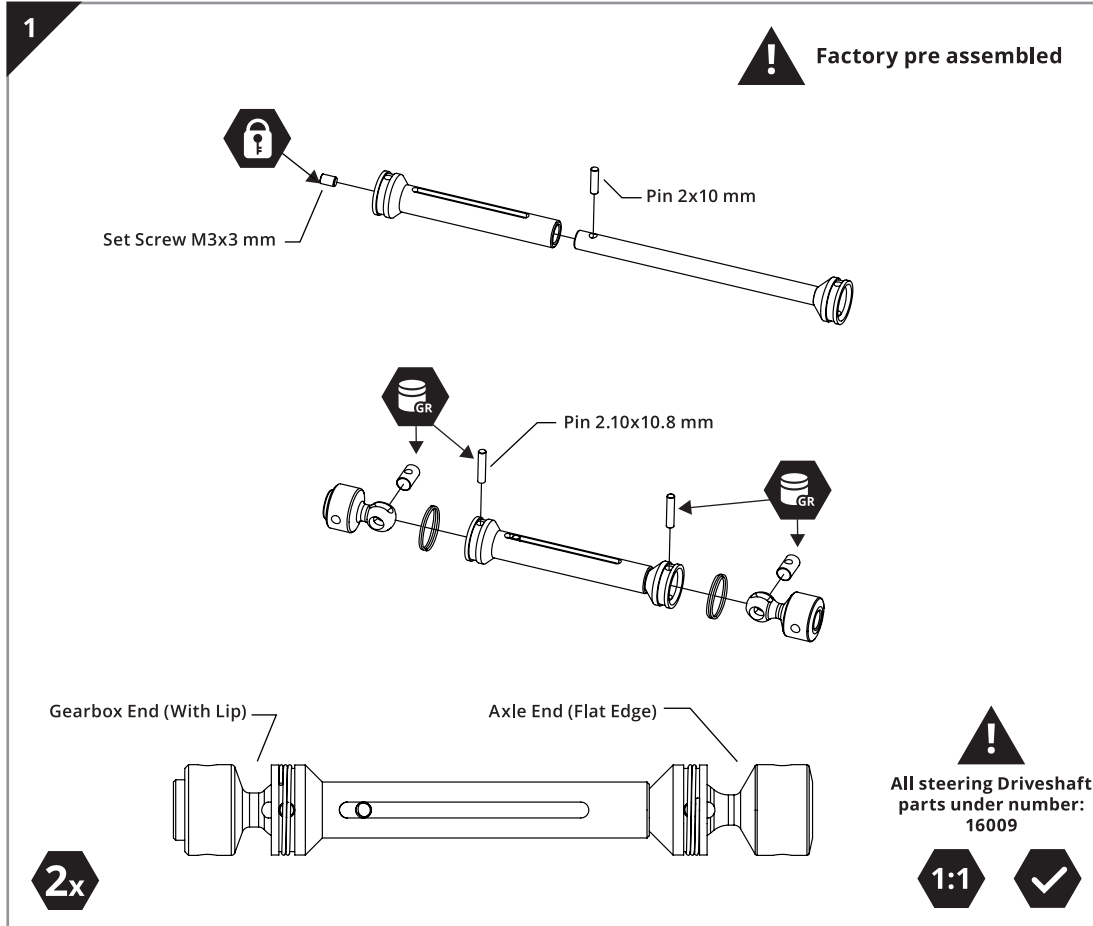

-  Pin 2x10 mm
-  Set Screw M3x3 mm
-  Pin 2.10x10.8 mm



# H STEP 1

BAG H / BEUTEL H  
SAC H /

## Gearbox Assembly



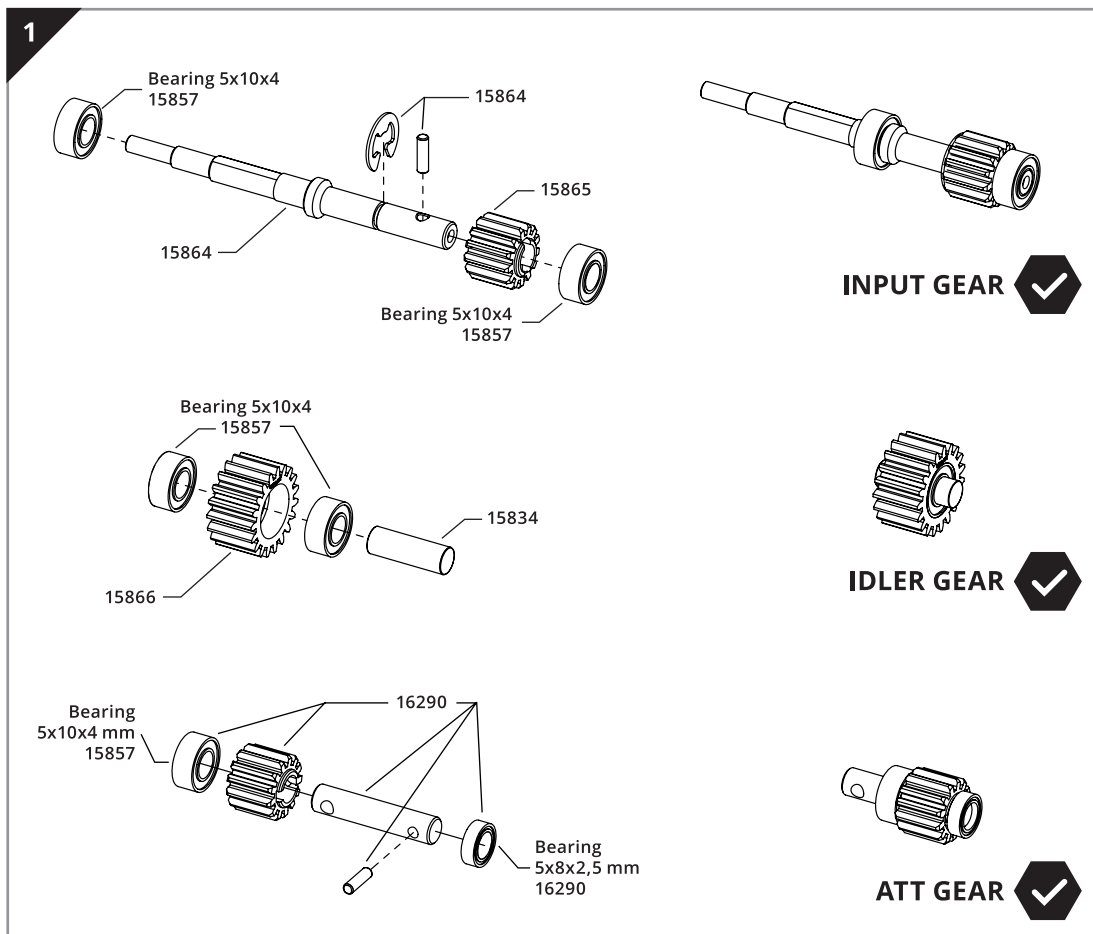



-  Pin 2x7 mm 16291
-  C Clip 3.5
-  Bearing 5x10x4 15857
-  Bearing 5x8x2,5 mm 16290



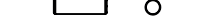

## Gearbox Assembly

# H STEP 2 - 4

BAG H / BEUTEL H  
SAC H /

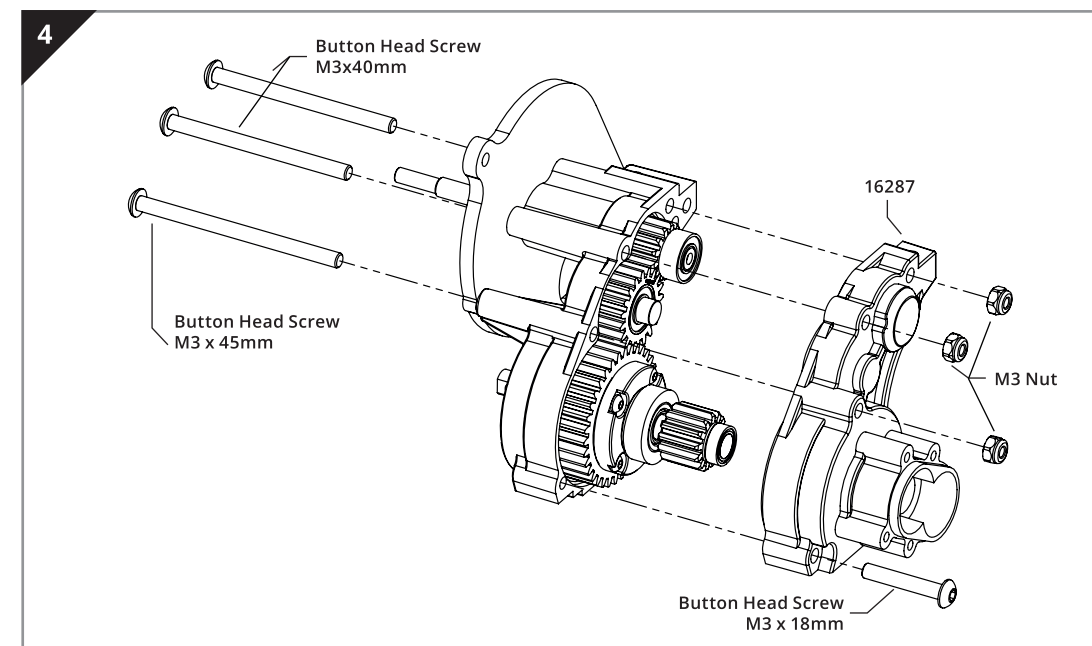
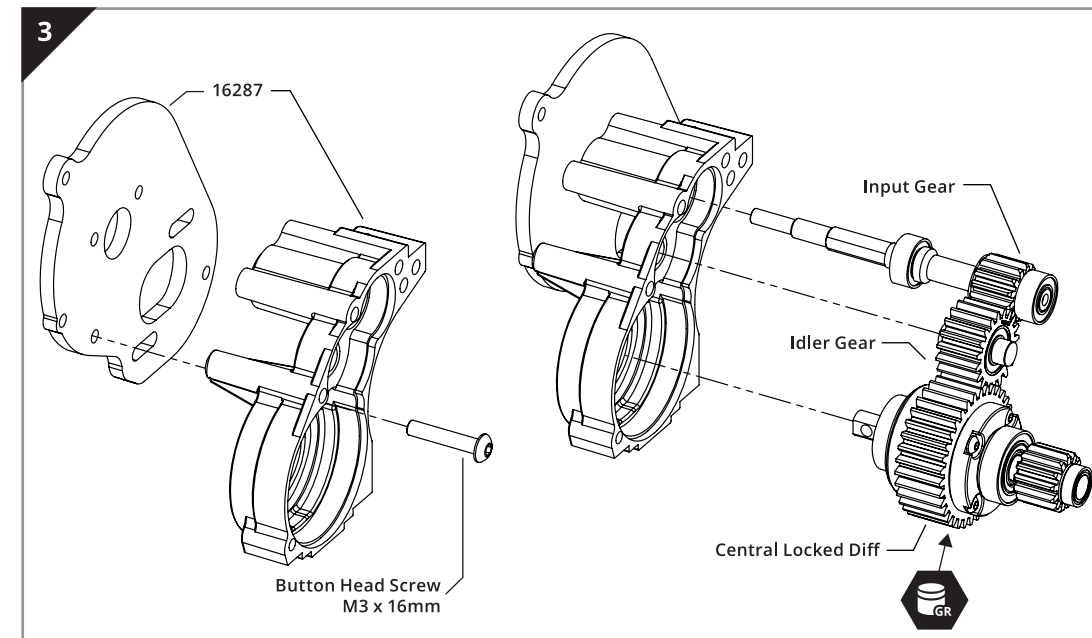
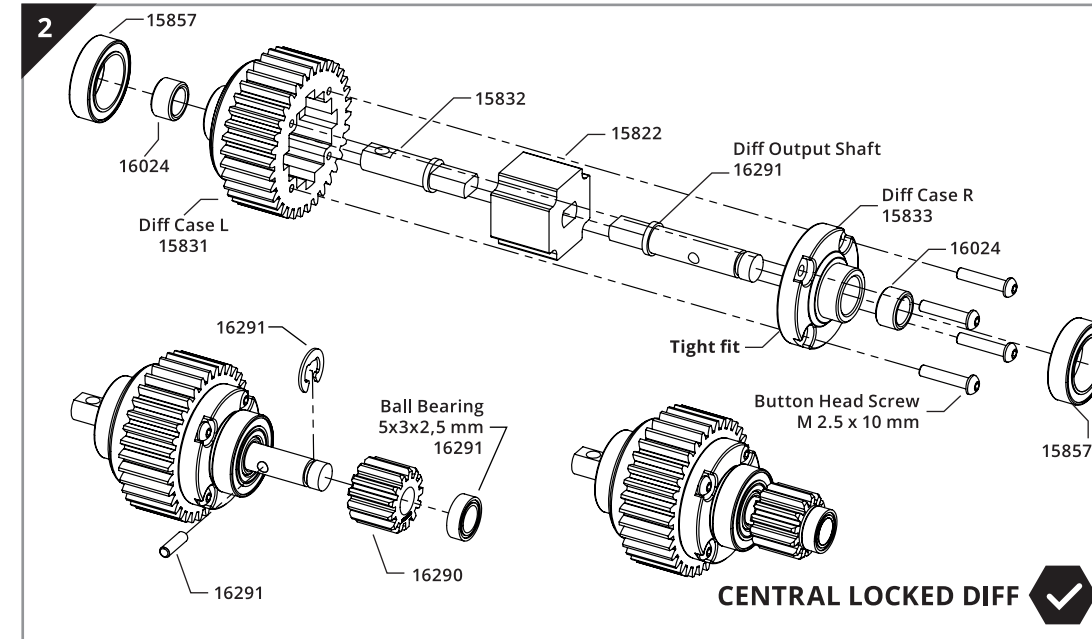
-  Bearing 10x15x4 15857
-  Diff Tube Spacer 16024
-  Button Head Screw M 2.5 x 10 mm
-  Pin 2x7 mm 16291
-  C Clip 3.5
-  Bearing 5x8x2,5 mm 16290
-  Button Head Screw M3 x 16mm



-  Button Head Screw M3 x 18mm / 40mm / 45mm



**H** STEP 5 - 7  
BAG H / BEUTEL H  
SAC H /

**Gearbox Assembly**

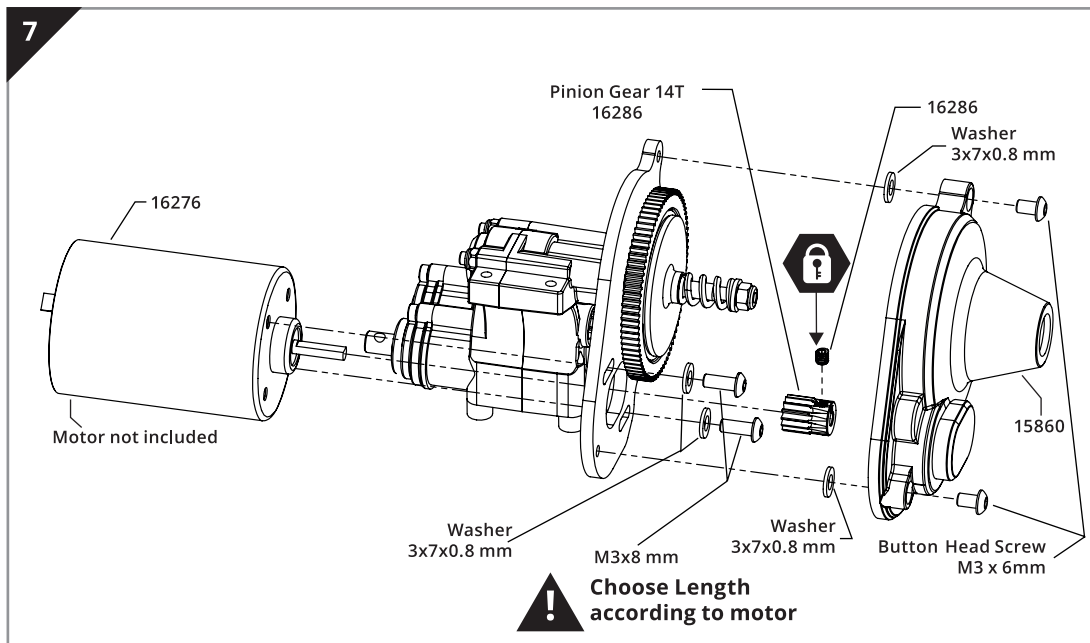
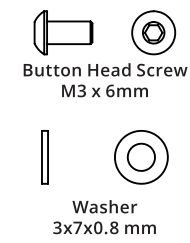
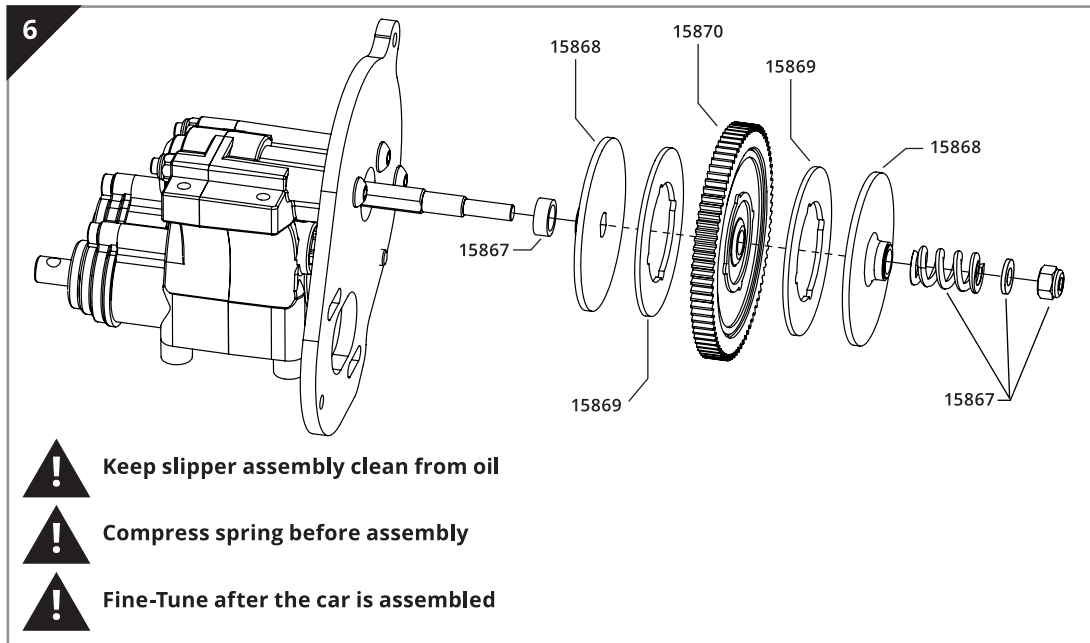
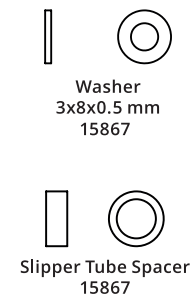
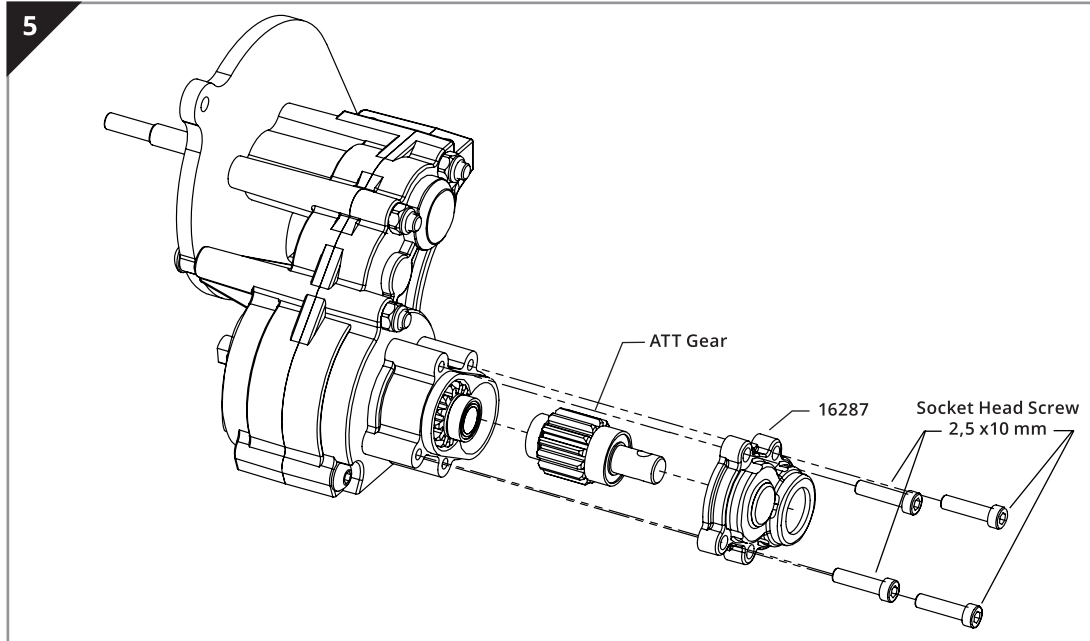
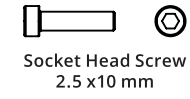

**Gearbox Assembly**

**H** STEP 8 - 10  
BAG H / BEUTEL H  
SAC H /

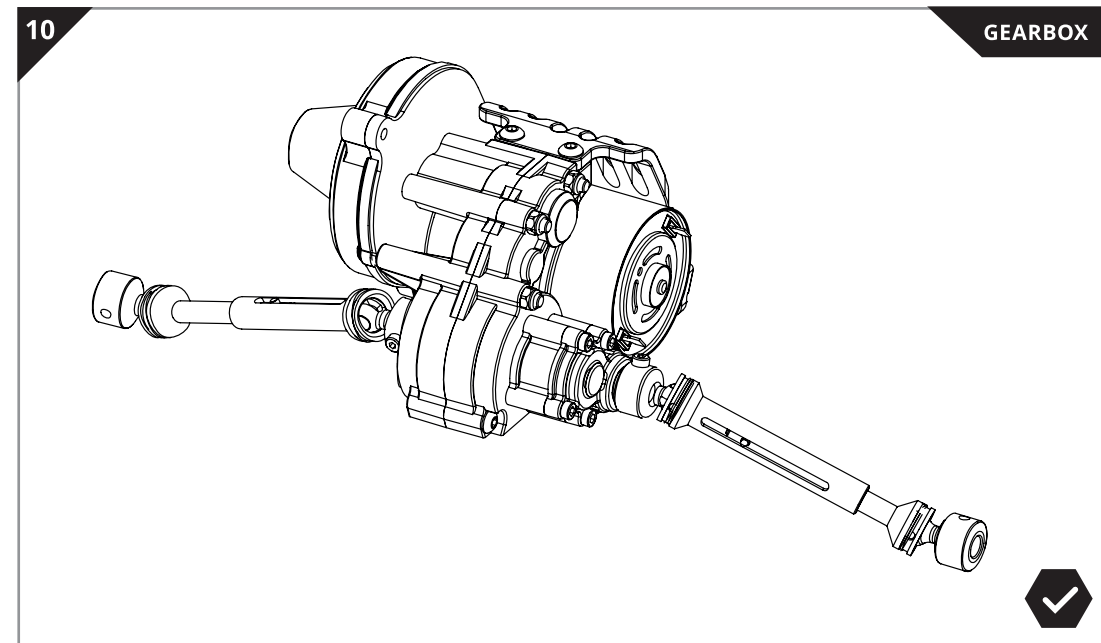
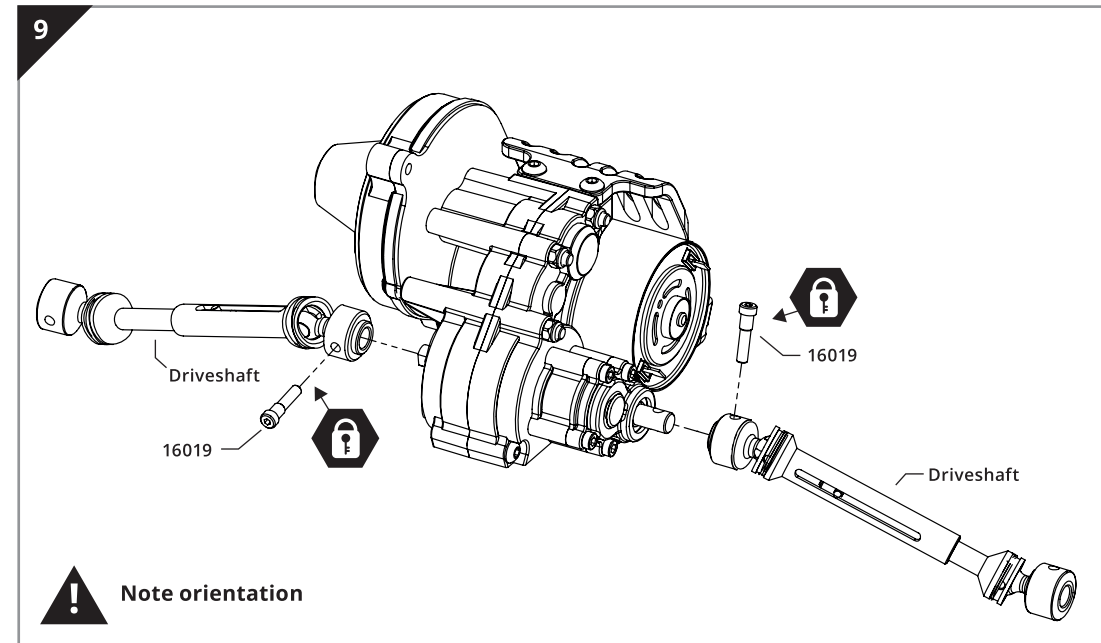
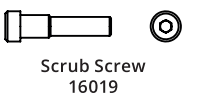
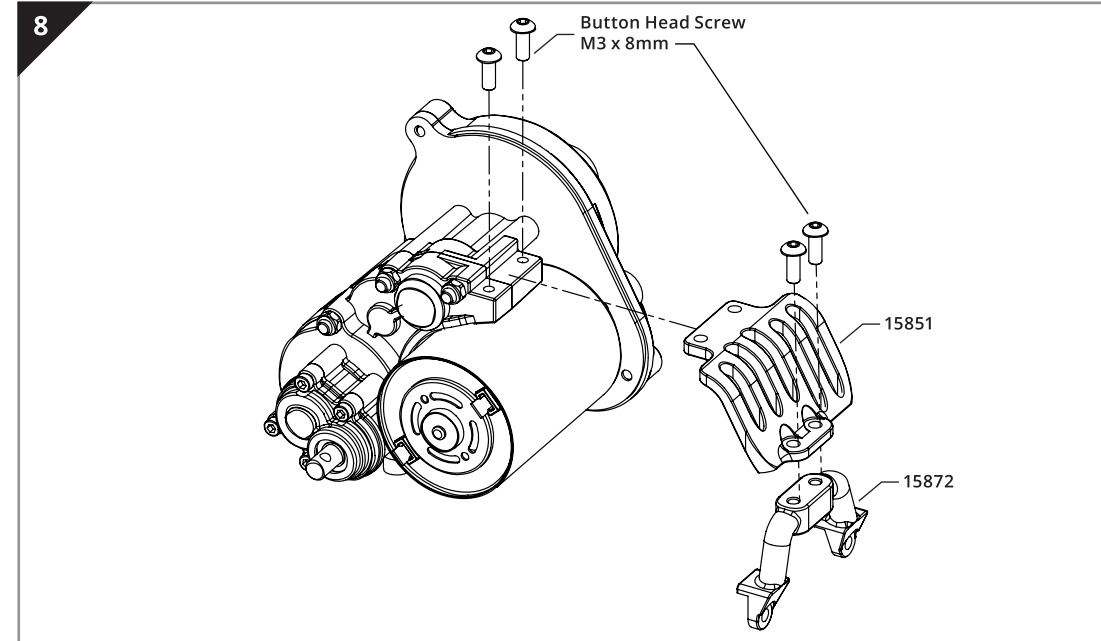
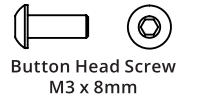

### STEP 1 - 3

BAG 1 / BEUTEL 1  
SAC 1 /

### Chassis Assembly

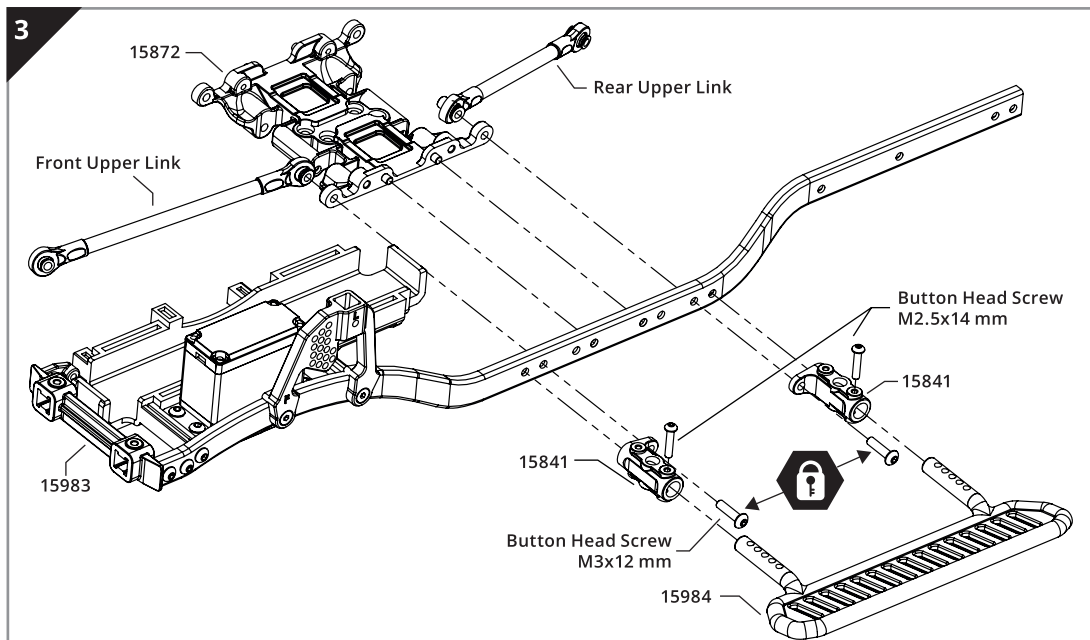
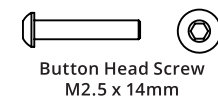
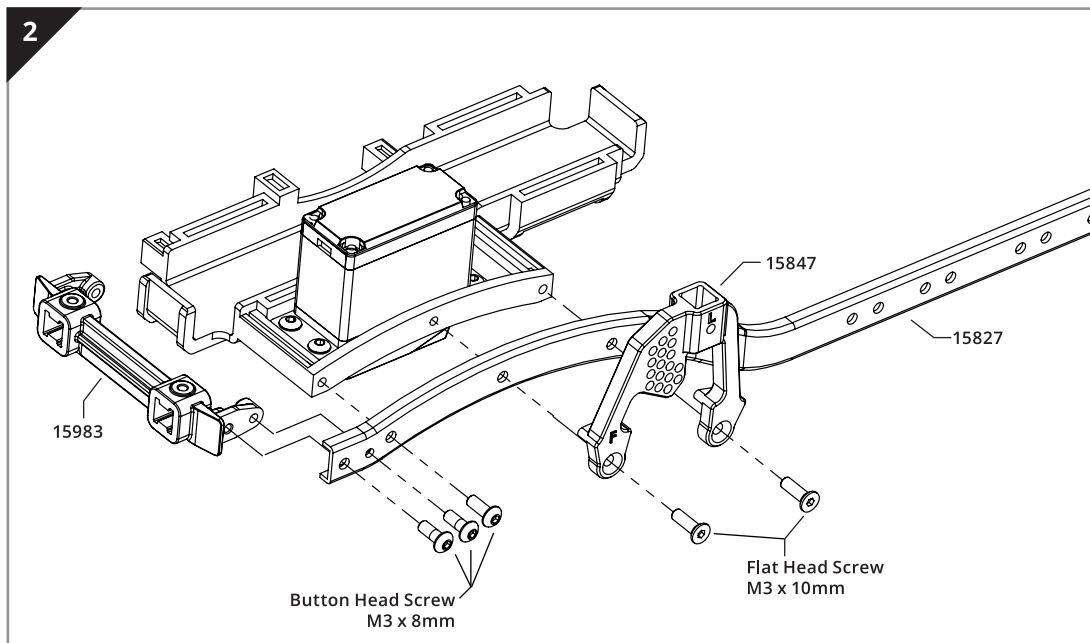
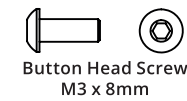
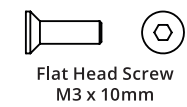
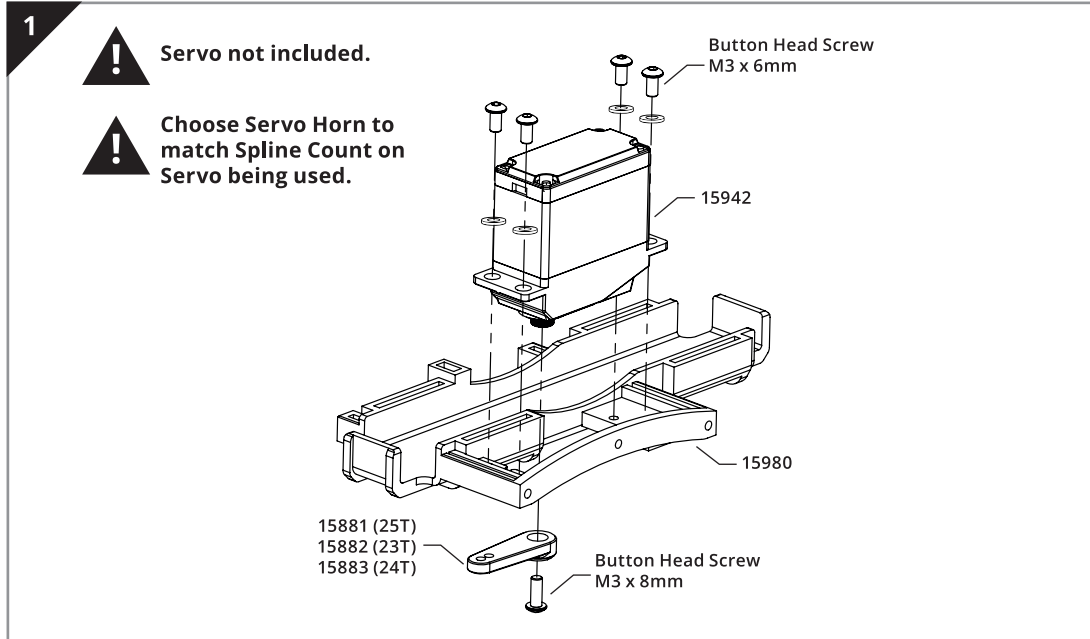
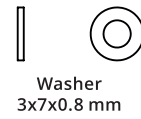
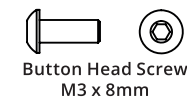
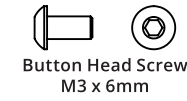

### Chassis Assembly

### STEP 4 - 6

BAG 1 / BEUTEL 1  
SAC 1 /

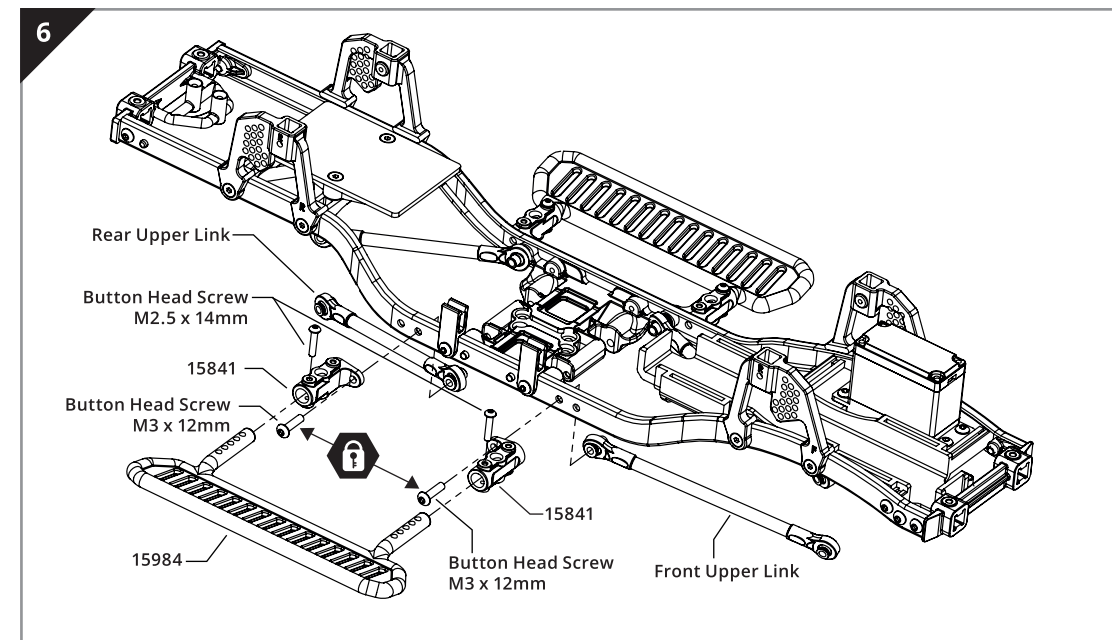
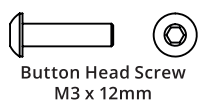
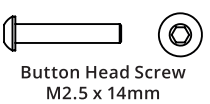
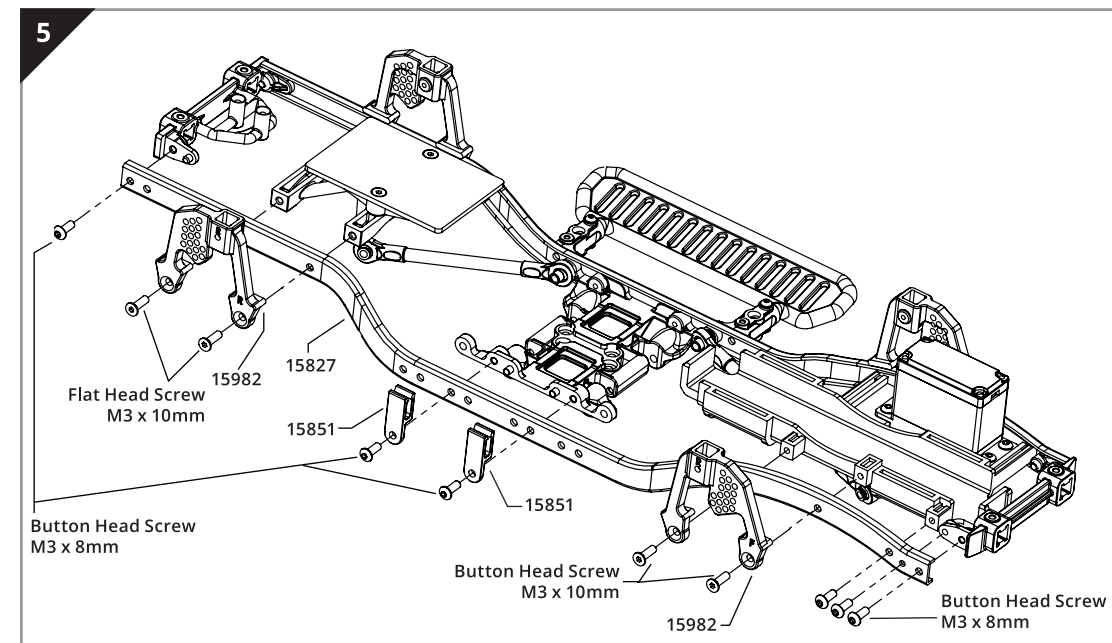
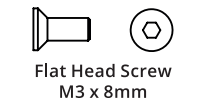
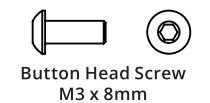
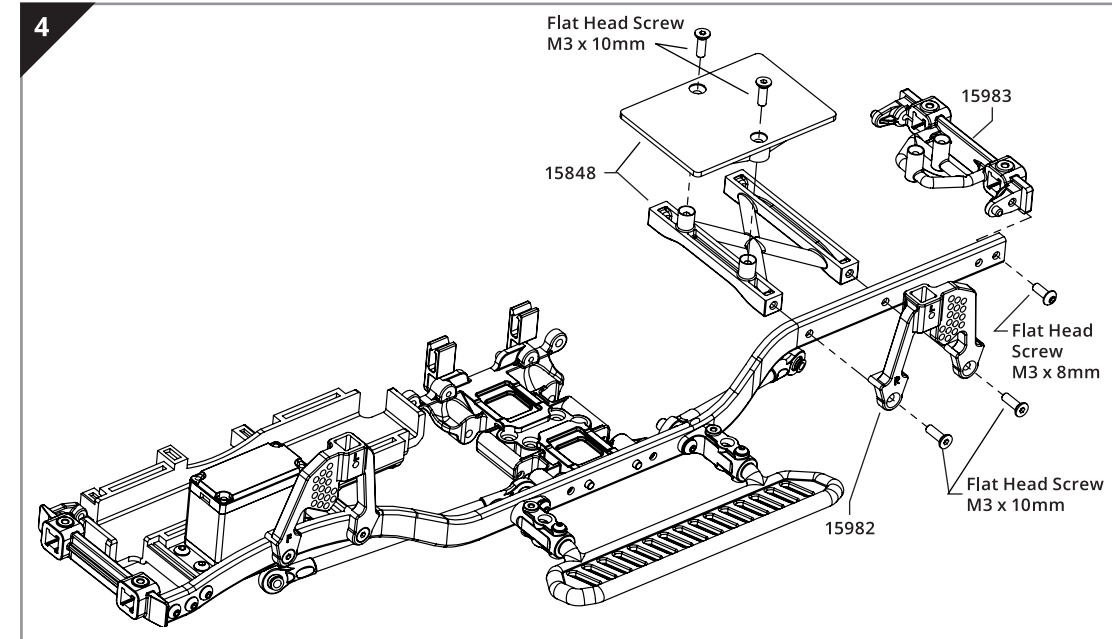
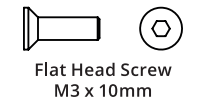



**STEP 7-9**

BAG I / BEUTEL I  
SAC I /

**Chassis Assembly**

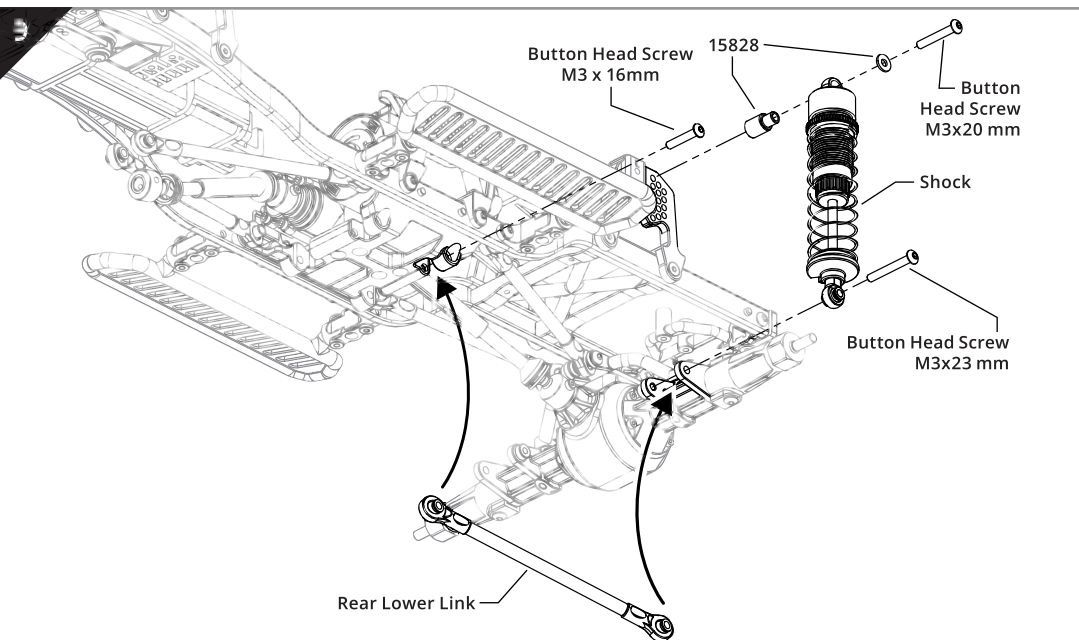
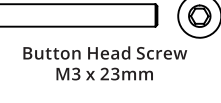
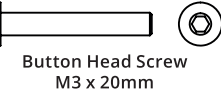
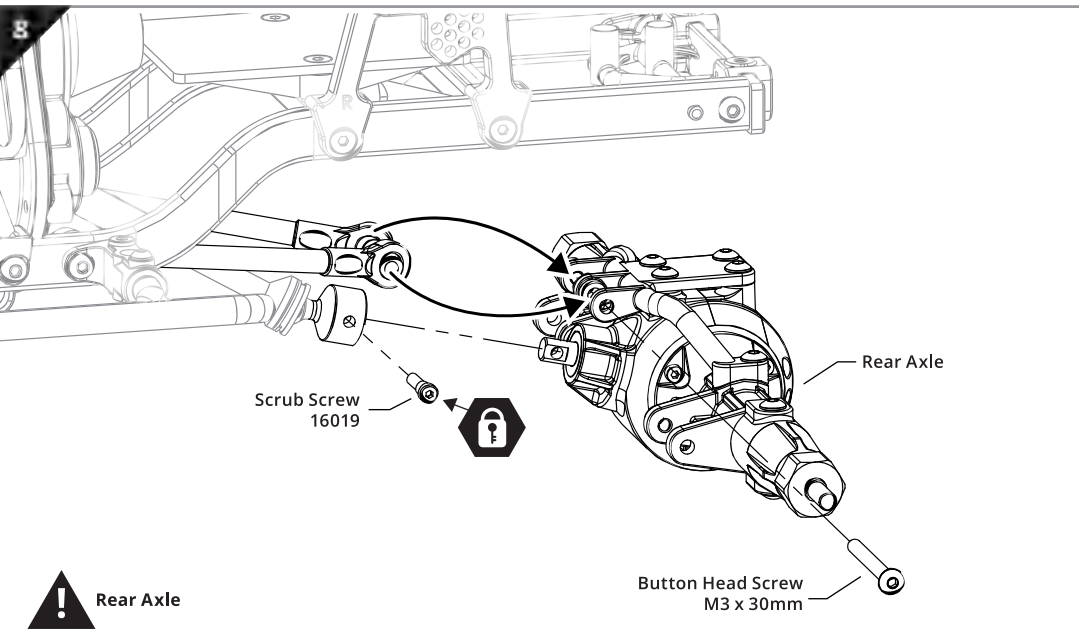
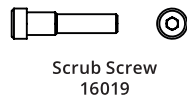
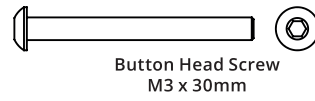
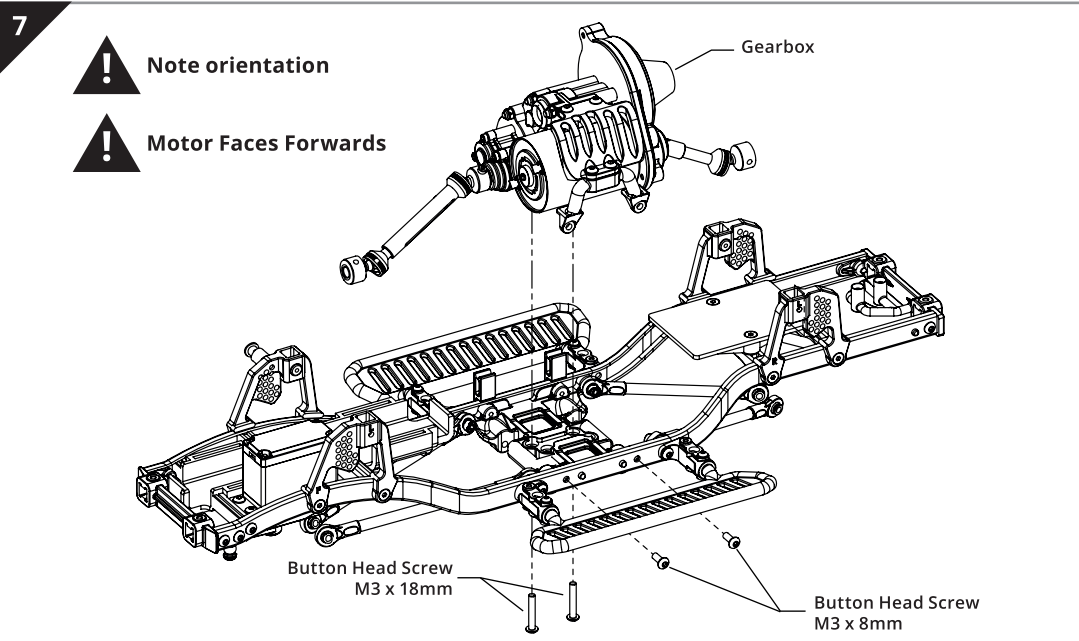
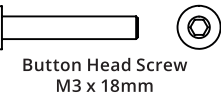
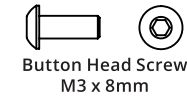

**Chassis Assembly**

**STEP 10-12**

BAG I / BEUTEL I  
SAC I /

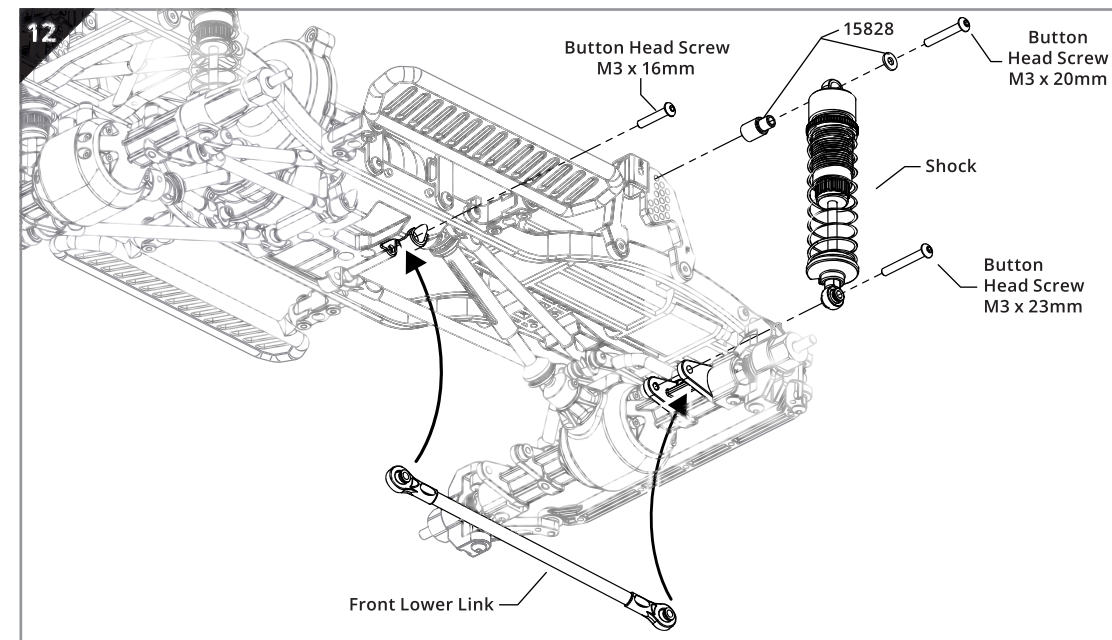
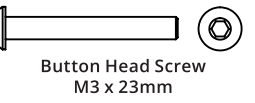
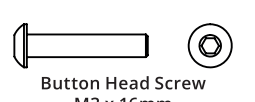
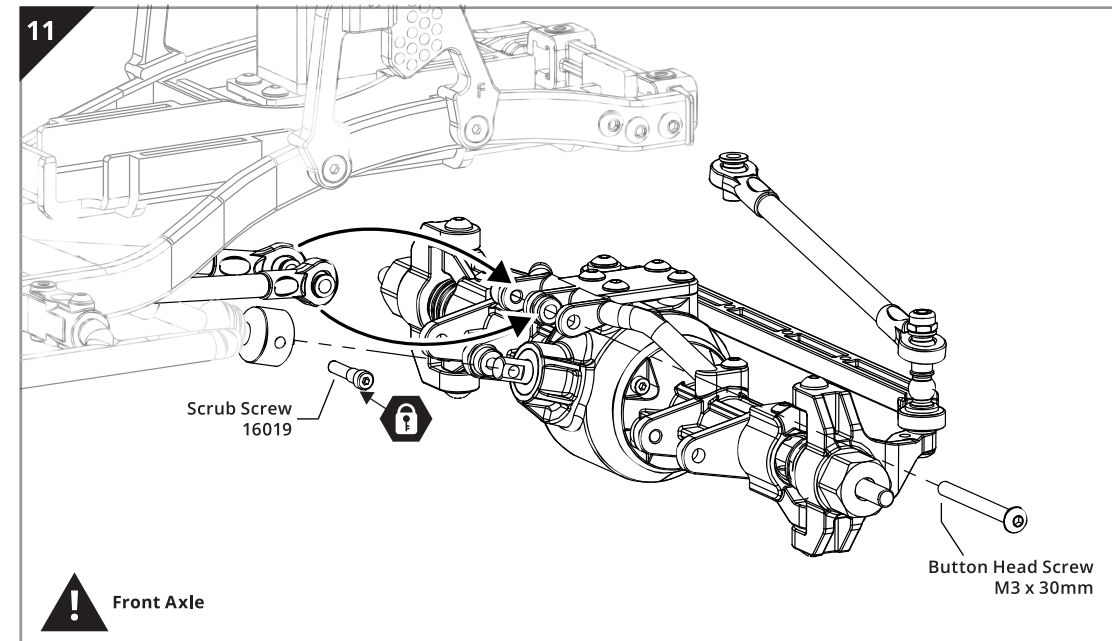
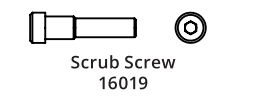
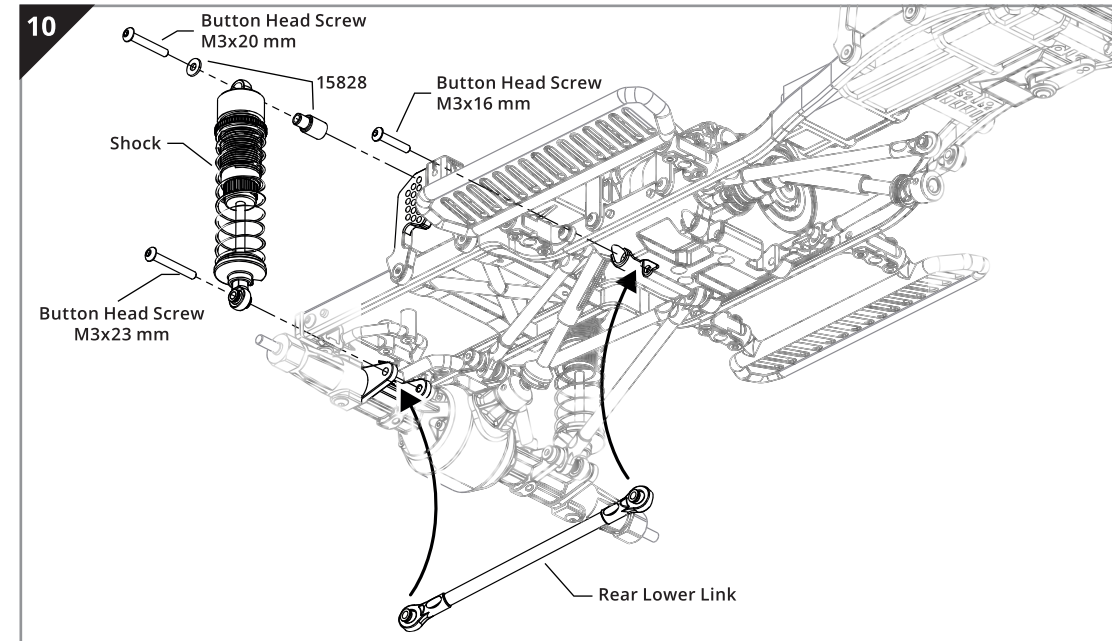
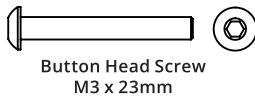
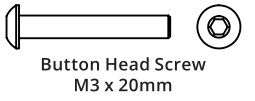
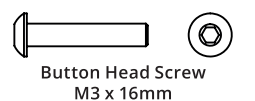



**STEP 13-15**

BAG I / BEUTEL I  
SAC I /

**Chassis Assembly**

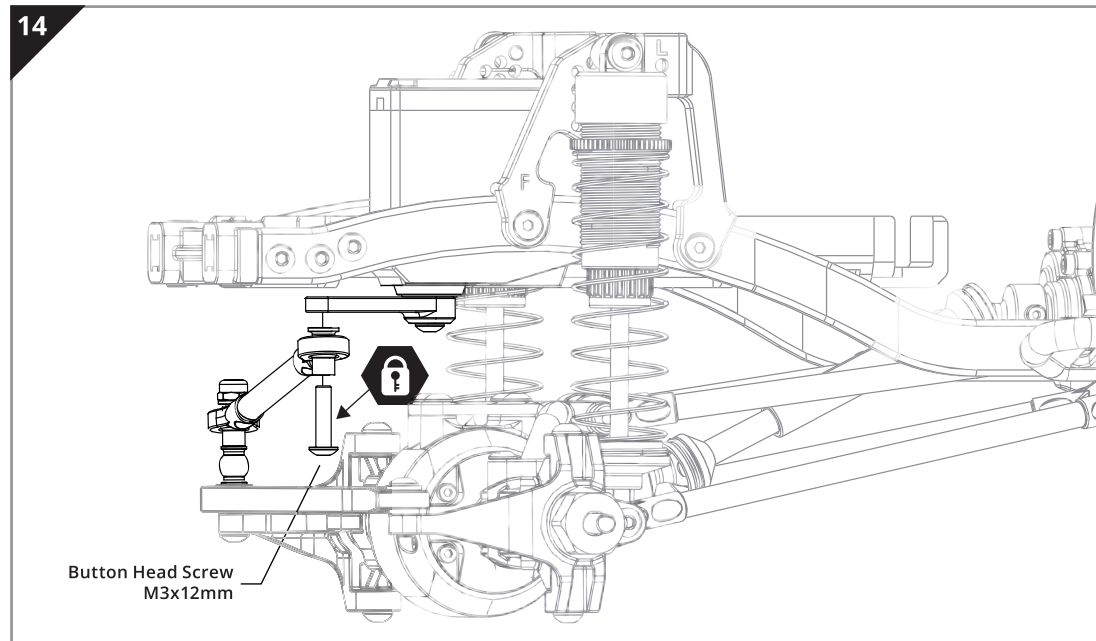
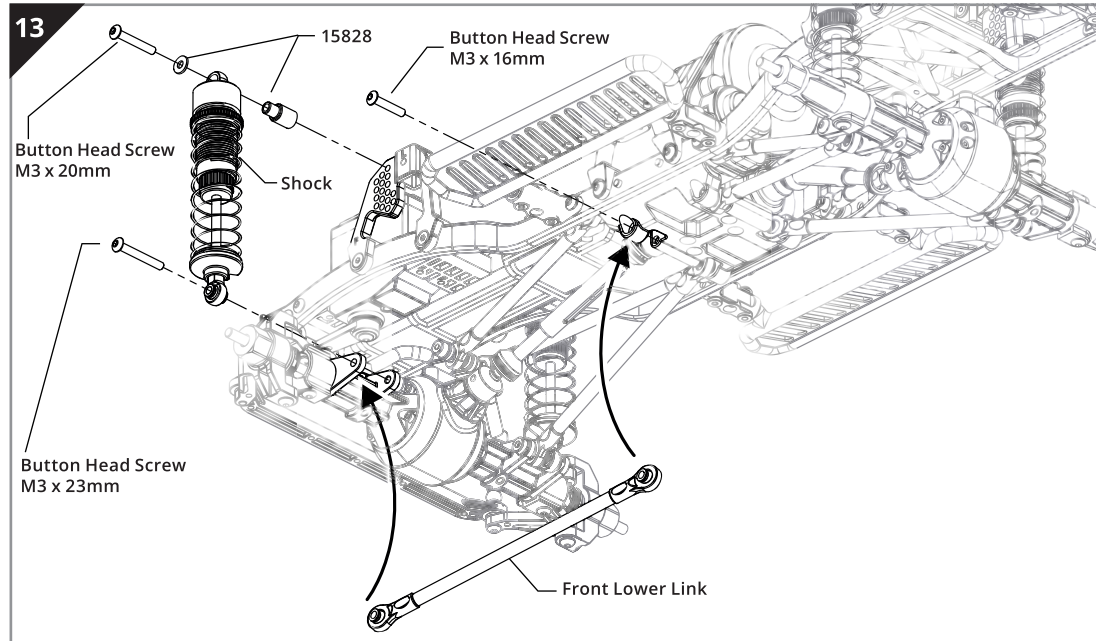
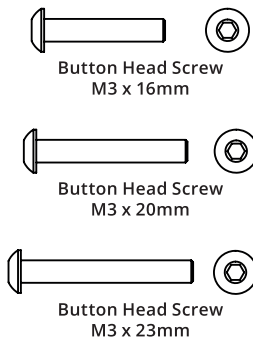

**STEP 1 - 1**

BAG J / BEUTEL J  
SAC J /

**Bumpers Assembly**

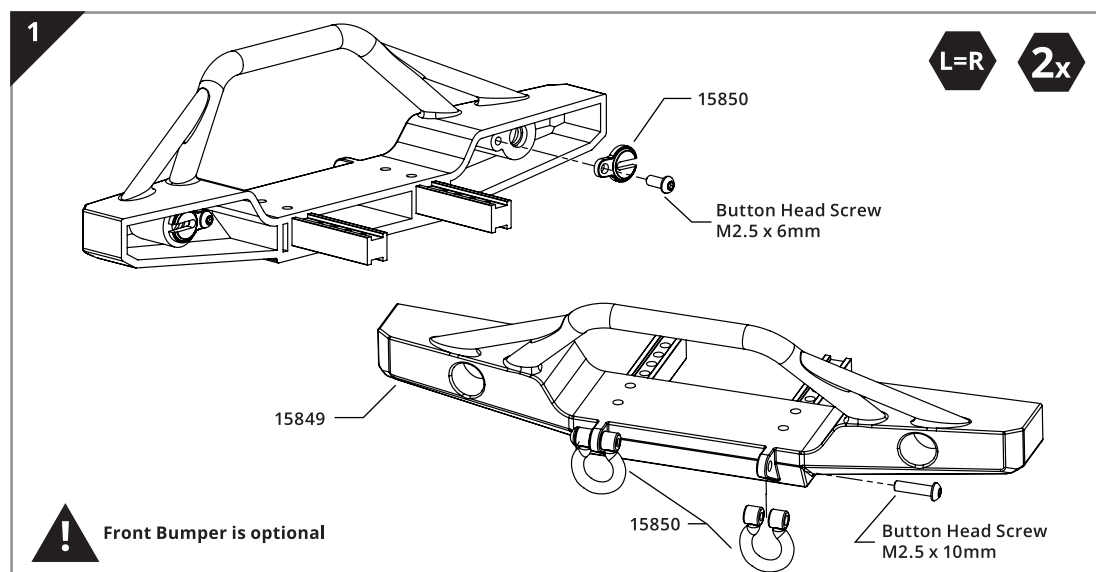
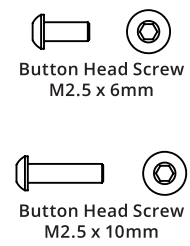

**Bumpers Assembly**

**STEP 2 - 4**

BAG J / BEUTEL J  
SAC J /

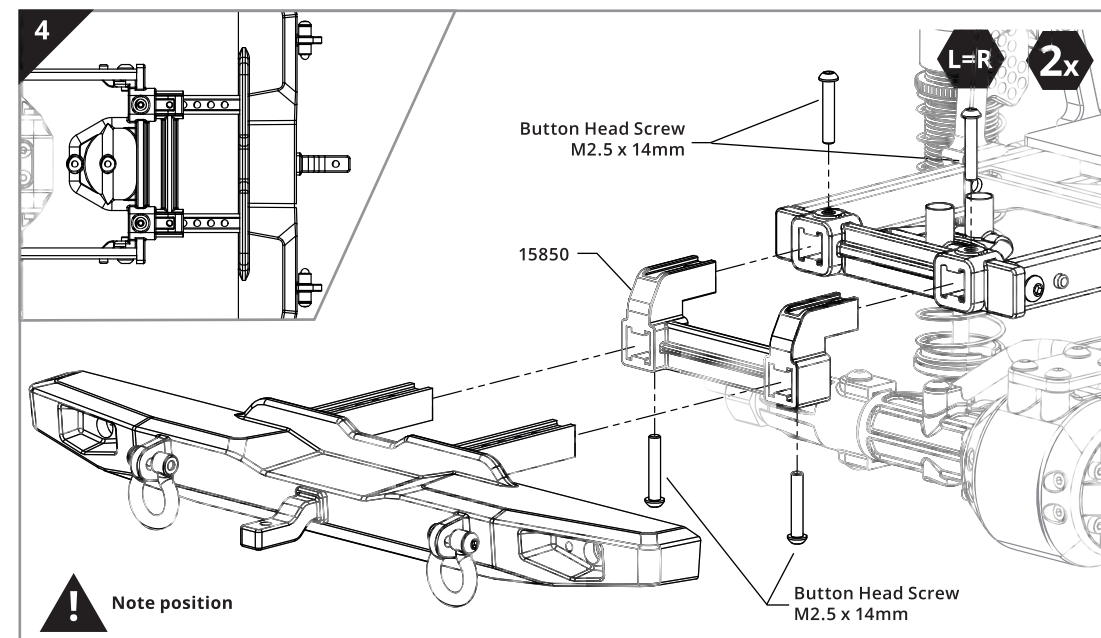
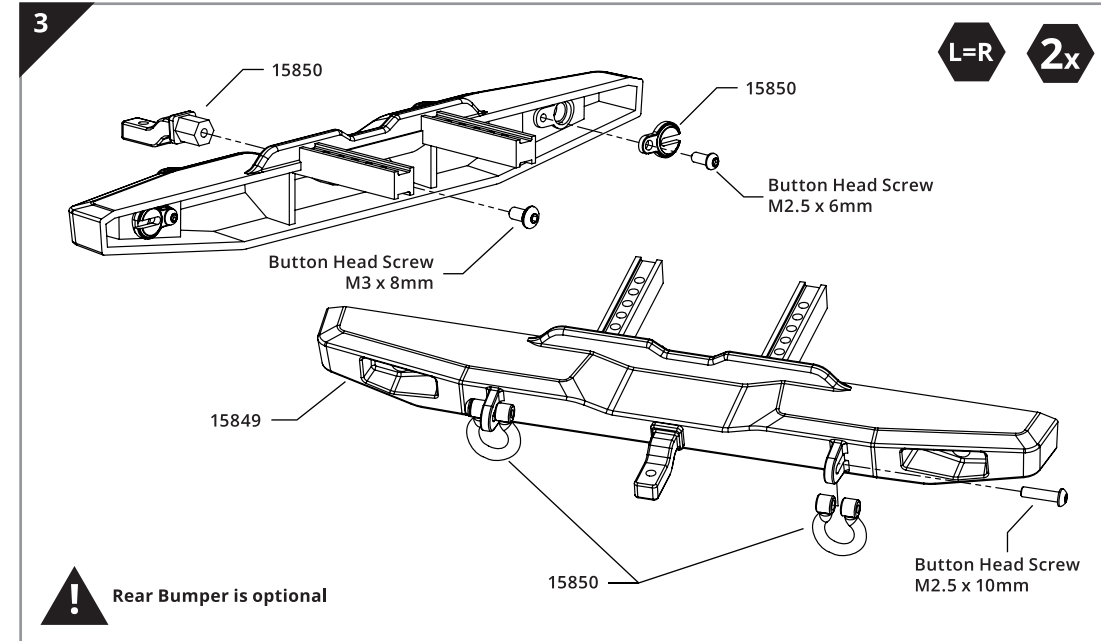
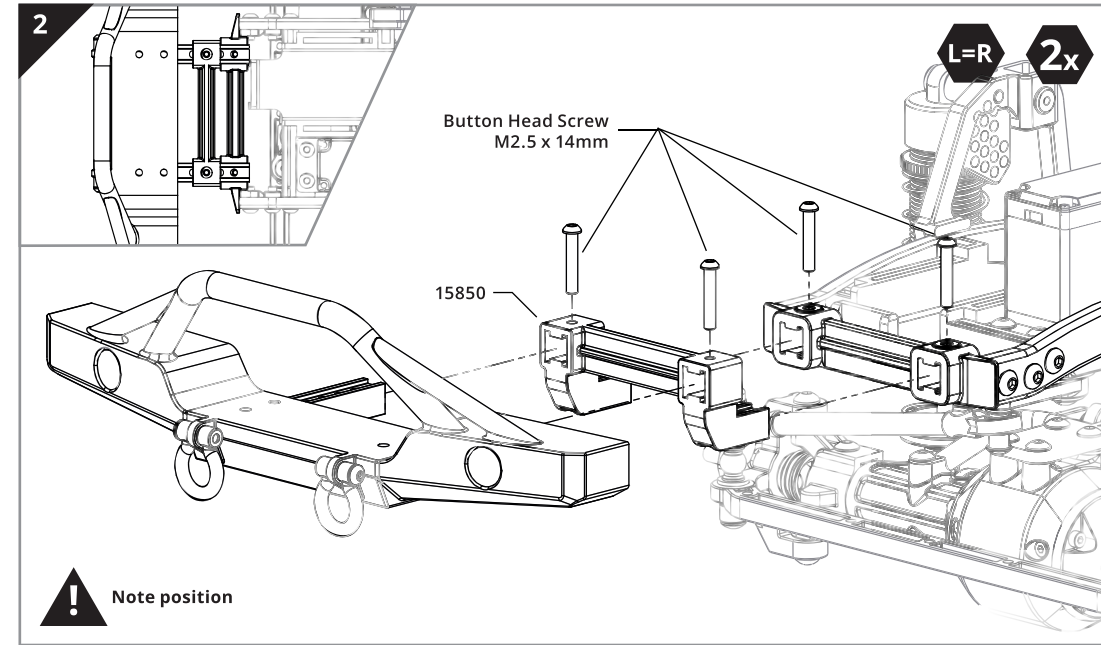
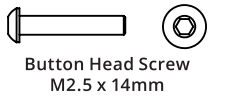

**K** STEP 1 - 1  
BAG K / BEUTEL K  
SAC K /

**Beadlock Wheel and Tyre Assembly**

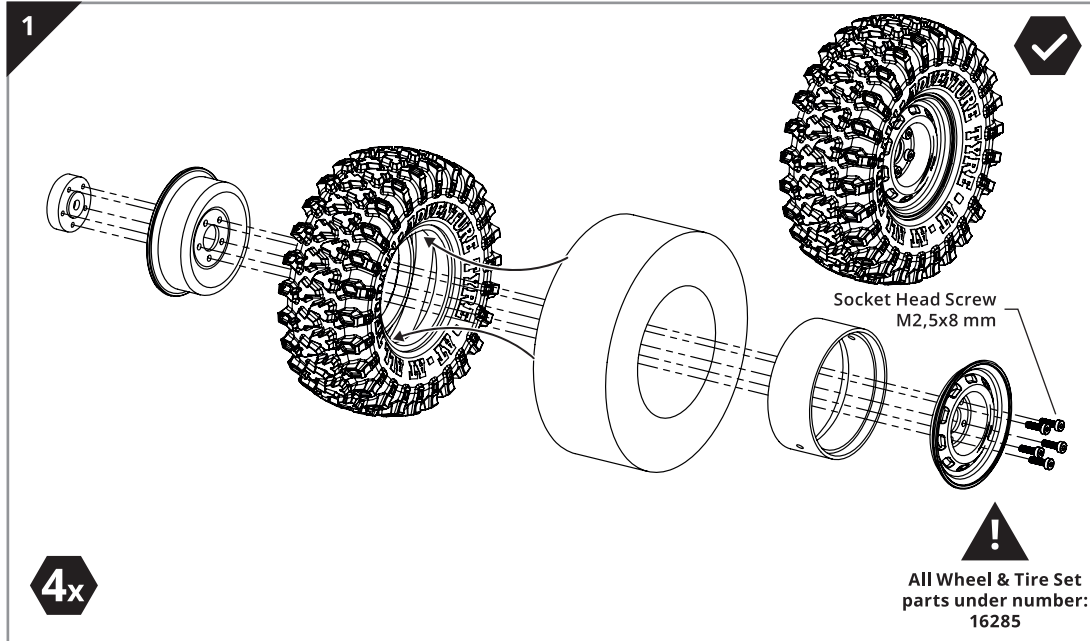
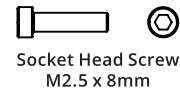

**Body Assembly**

**L** STEP 1 - 4  
BAG L / BEUTEL L  
SAC L /

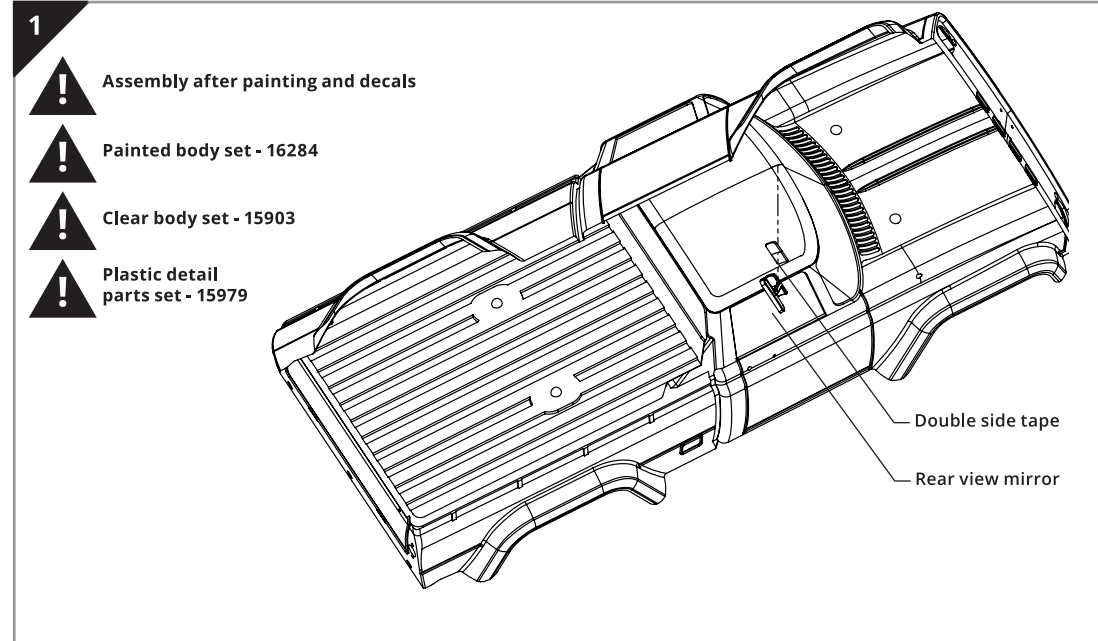

**K** STEP 1-1  
BAG K / BEUTEL K  
SAC IK /

**Chassis Assembly**

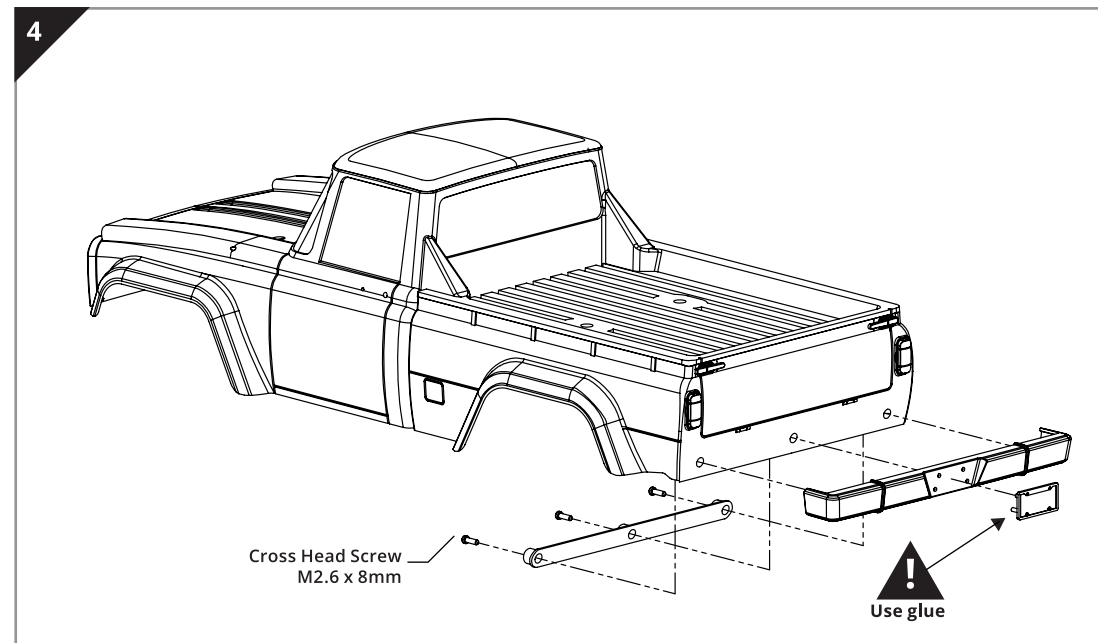
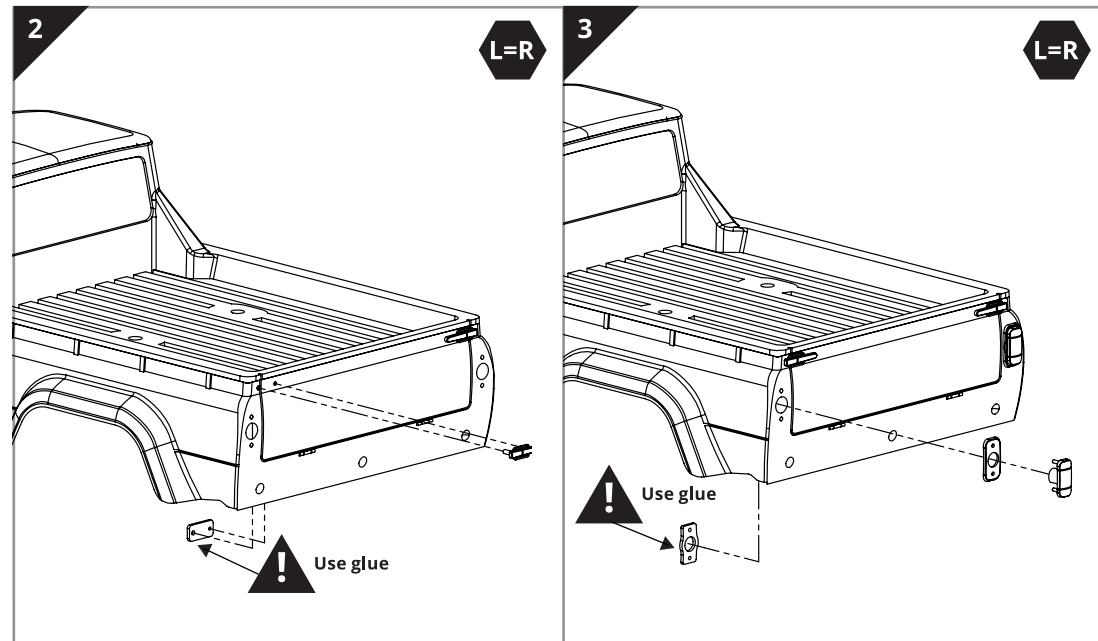
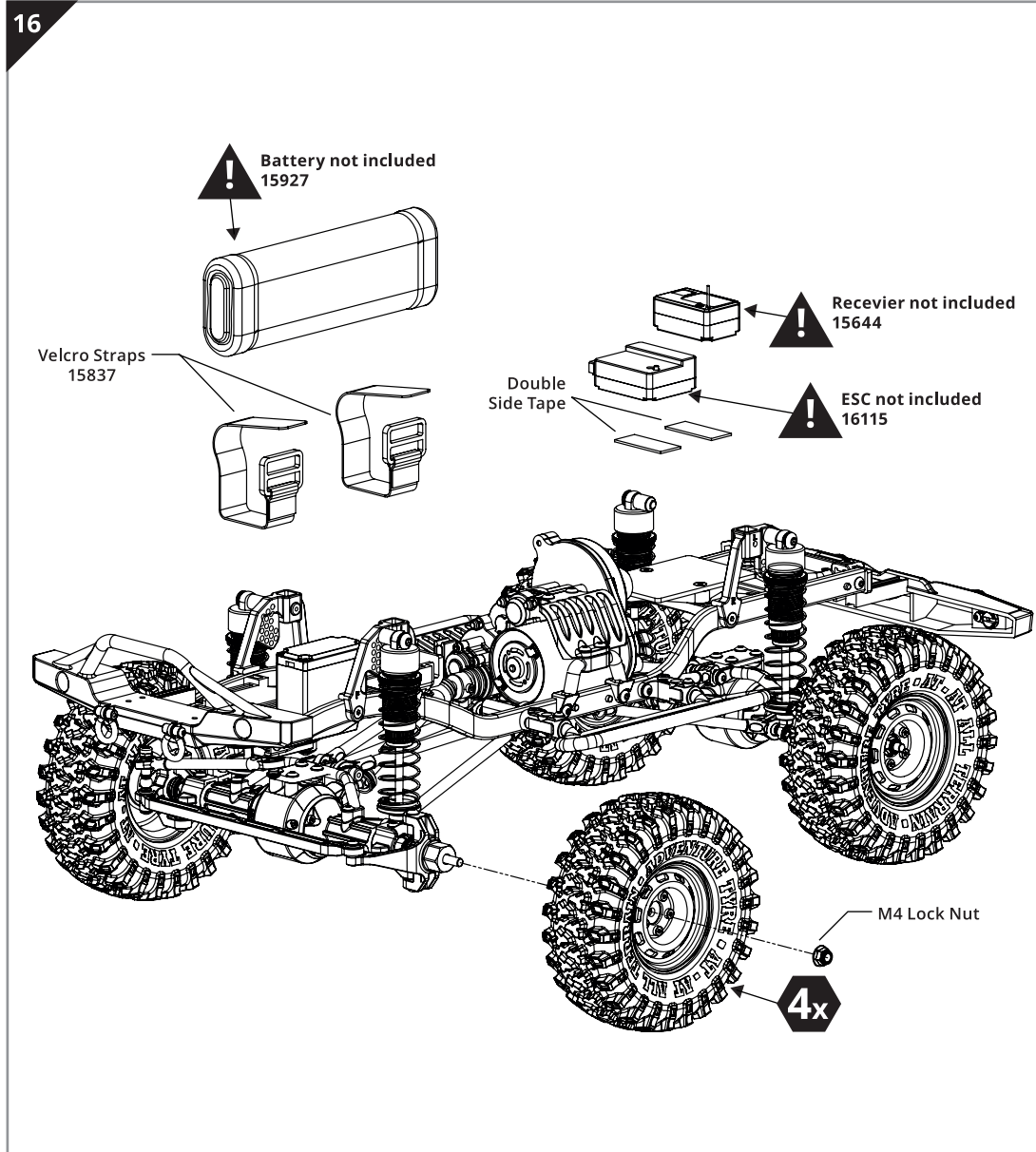



**STEP 5 - 7**

BAG L / BEUTEL L  
SAC L /

**Body Assembly**

 Cross Head Screw  
M2.6 x 8mm

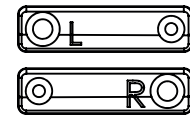
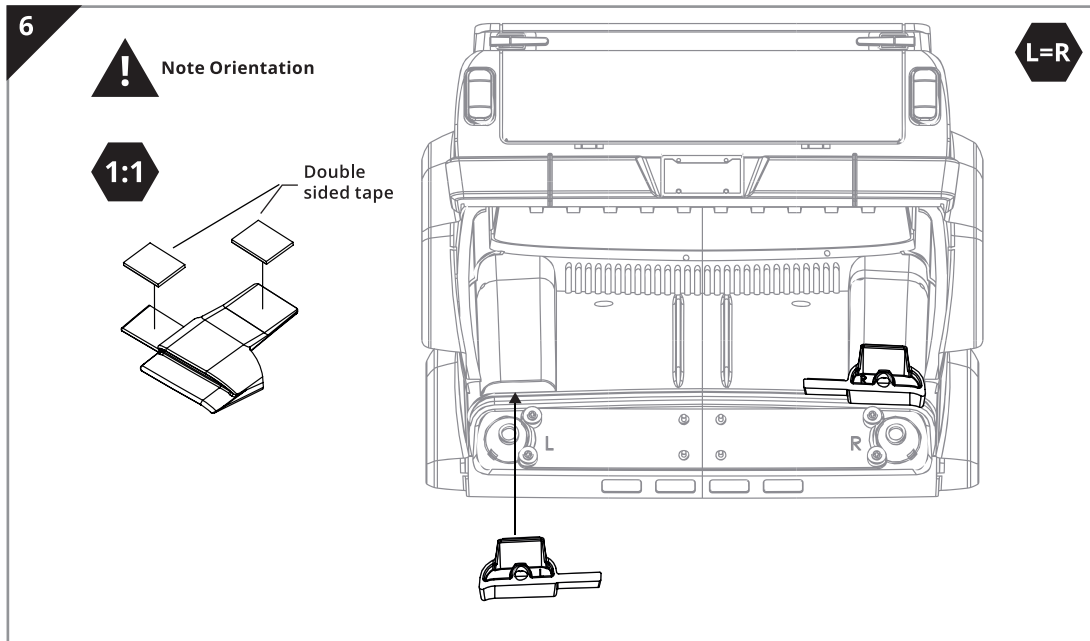
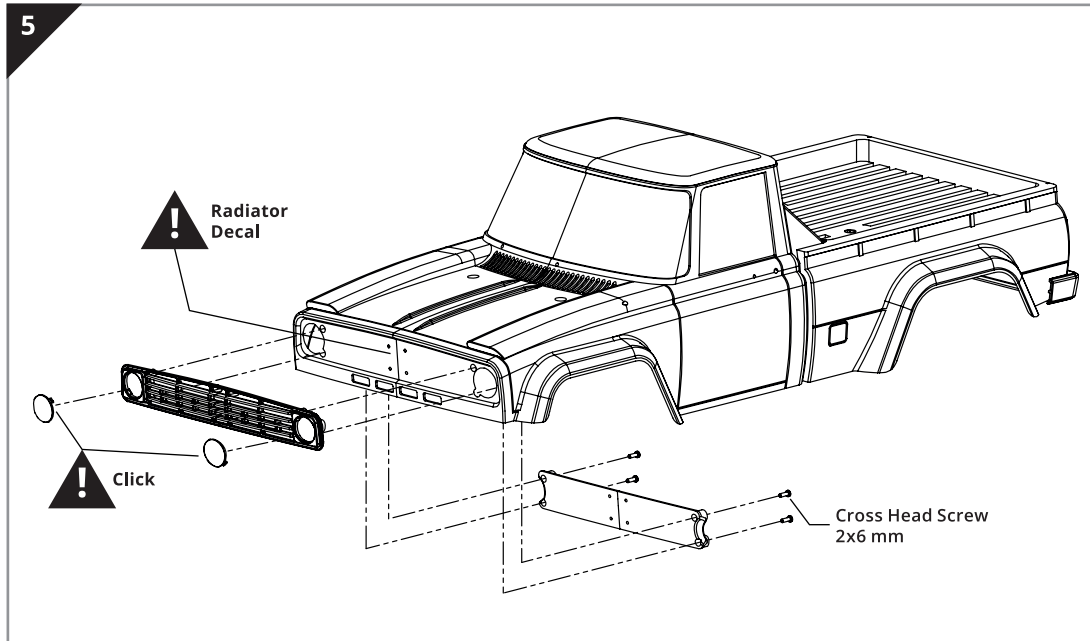

! Note Orientation

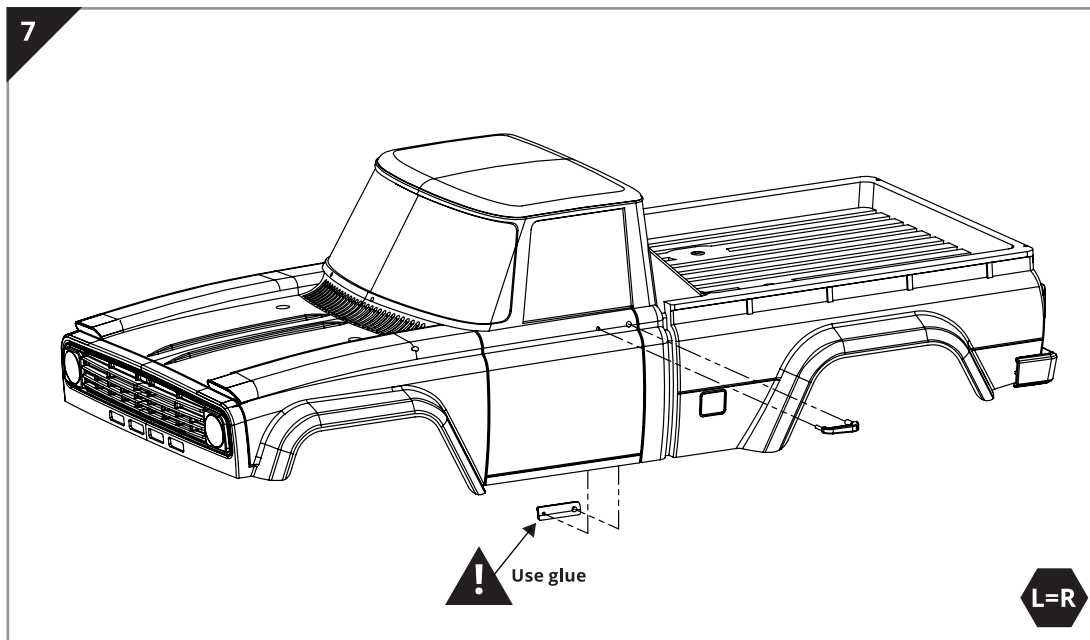

**Body Assembly**

**STEP 8 - 9**

BAG L / BEUTEL L  
SAC L /

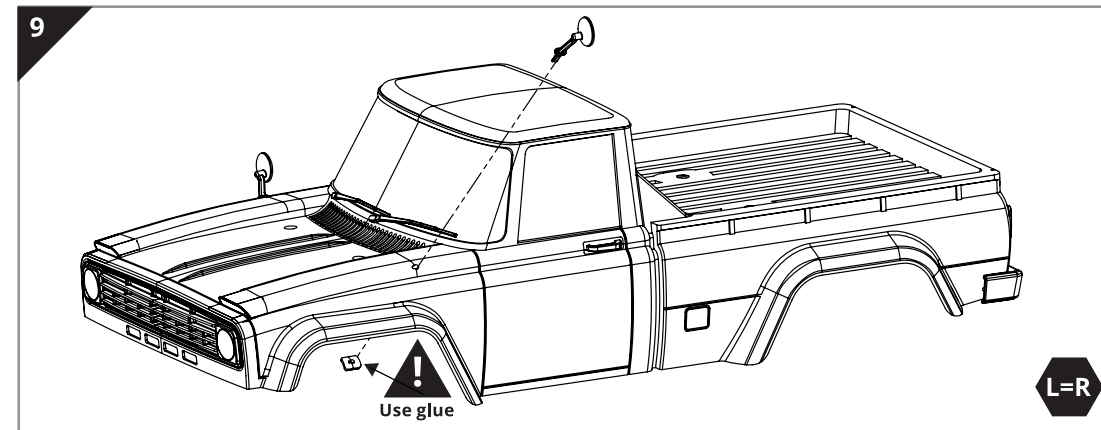
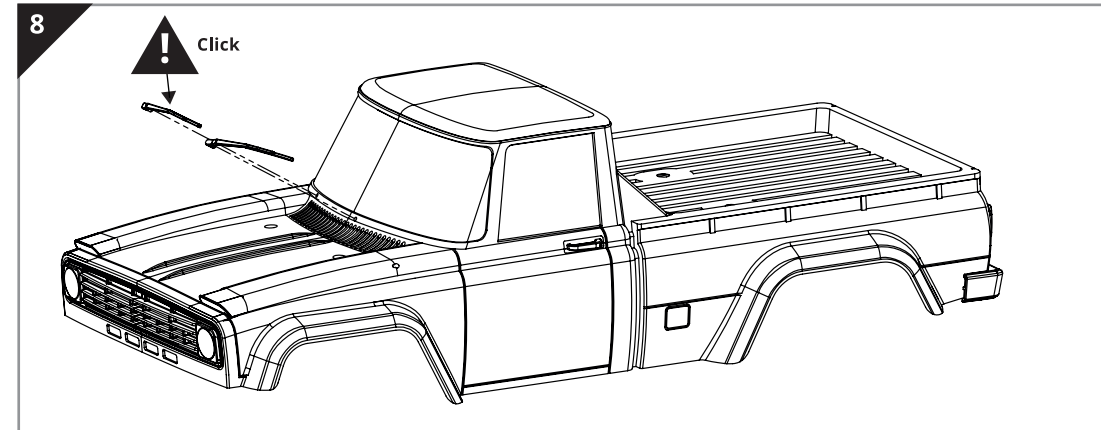

! Note Orientation

**Final Assembly**

**M STEP 1 -1**

BAG L / BEUTEL L  
SAC L /

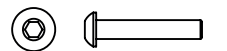
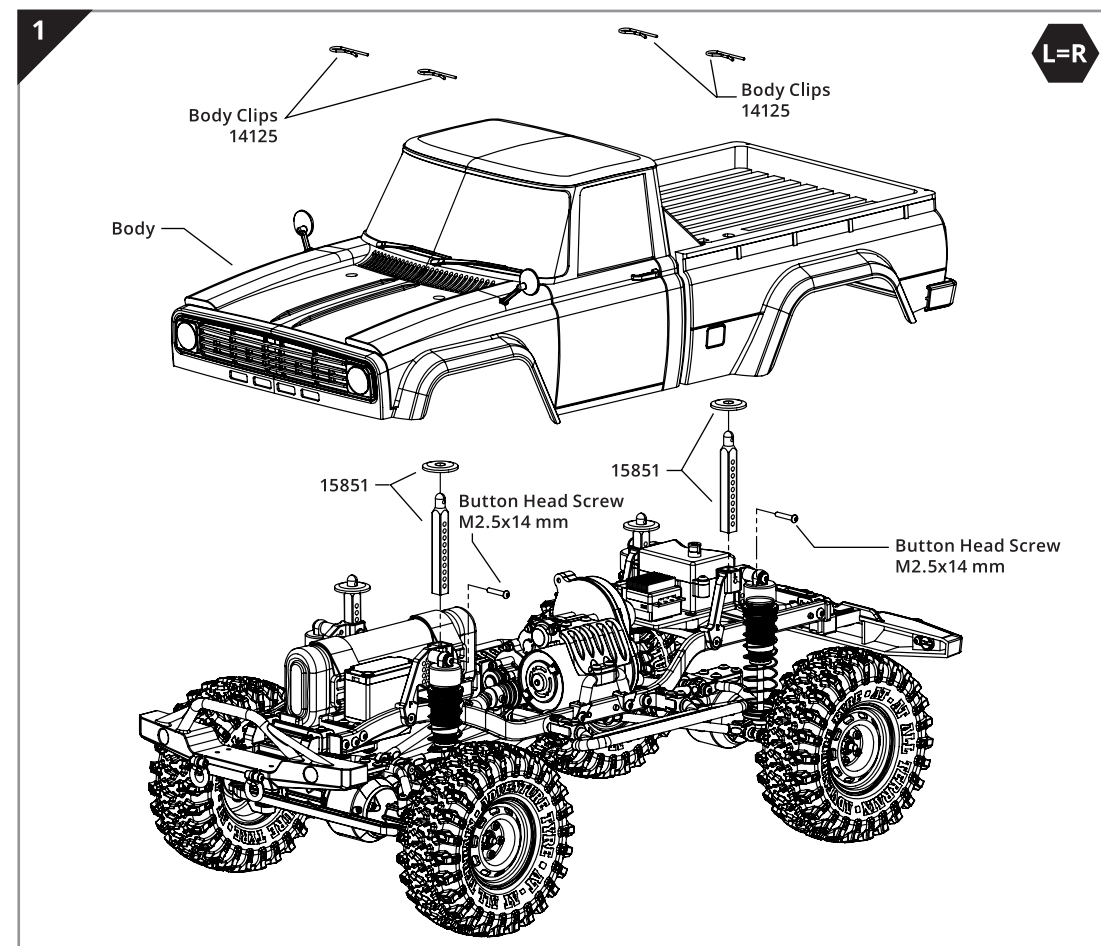

Button Head Screw  
M2.5x14 mm

! Note position

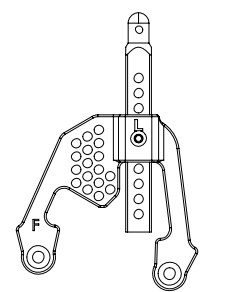

FRONT TOWER

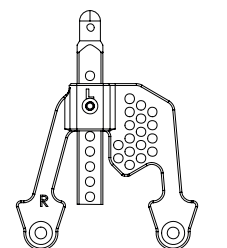

REAR TOWER



# CONGRATULATIONS!

## YOUR COYOTE 2.1 IS READY TO GO

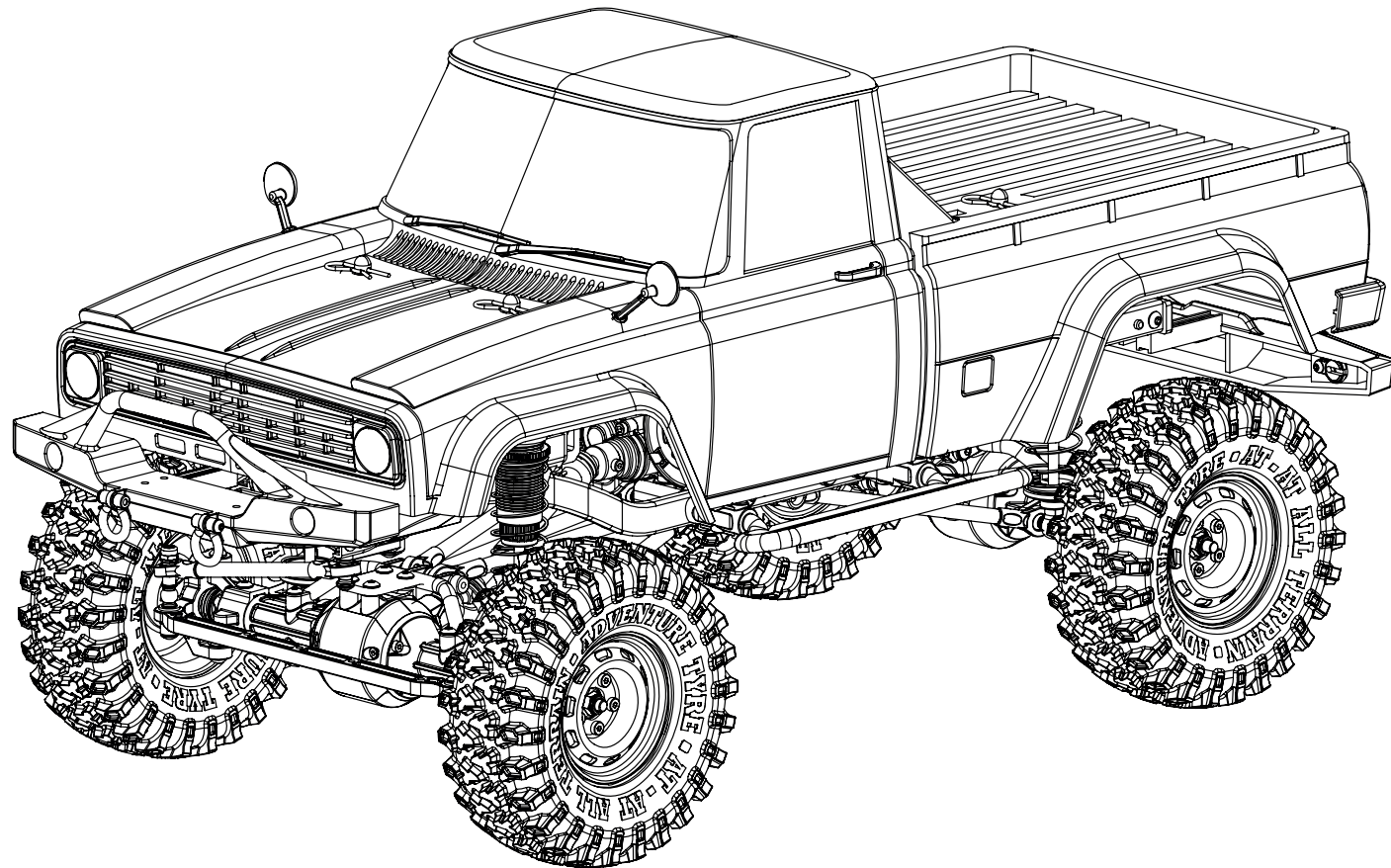

Thank you for joining the Global Carisma family. Your newly built SCA-1E 2.1 will reward you with many hours of Scale Adventure and is the perfect starting point into this aspect of the RC Hobby.

Keep informed with all the latest news and product information at:

[www.carismascaleadventure.com](http://www.carismascaleadventure.com)

and follow and like us on Facebook, YouTube, Instagram and Tik Tok. Be a part of the ever growing CSA users groups and mix in real life and online with like minded people.

***“Enjoy the Adventure and savour the Journey...”***

### Spare Parts List

#### PART DESCRIPTION

|       |  |       |   |
|-------|--|-------|---|
| 15821 | SCA-1E 39T DIFFERENTIAL CROWN GEAR         | 15867 | SCA-1E SLIPPER HARDWARE SET                                       |
| 15822 | SCA-1E DIFFERENTIAL LOCKER                 | 15868 | SCA-1E SLIPPER PLATE SET  |
| 15823 | SCA-1E DIFFERENTIAL CASE SET               | 15869 | SCA-1E SLIPPER PADS   |
| 15824 | SCA-1E 16T DIFFERENTIAL INPUT PINION       | 15870 | SCA-1E SPUR GEAR 83T  |
| 15826 | SCA-1E REAR AXLE DRIVE SHAFT               | 15872 | SCA-1E 4-LINK SKID PLATE  |
| 15827 | SCA-1E LADDER CHASSIS (285mm)              | 15881 | SCA-1E ALUMINIUM SERVO ARM 25T                                    |
| 15828 | SCA-1E OIL SHOCKS SET                      | 15882 | SCA-1E ALUMINIUM SERVO ARM 24T                                    |
| 15834 | SCA-1E DIFFERENTIAL PINION PIN 5X14.7      | 15883 | SCA-1E ALUMINIUM SERVO ARM 23T                                    |
| 15835 | SCA-1E SLIPPER SET                         | 15980 | SCA-1E CHASSIS MOUNTED SERVO AND FORWARD MOUNTED BATTERY TRAY SET |
| 15840 | SCA-1E F&R DIFFERENTIAL CASE               | 15984 | SCA-1E V2 NARROW TYPE ROCK SLIDER PR                              |
| 15841 | SCA-1E F&R AXLE CASING HALF                | 16009 | SCA-1E DRIVE SHAFT (S)  |
| 15841 | SCA-1E F&R AXLE CASING HALF                | 16276 | SCA-1E 17T 5POLE BRUSHED MOTOR (545)                              |
| 15842 | SCA-1E REAR AXLE LOCKOUT                   | 16284 | SCA-1E COYOTE 2.1 PAINTED BODY SET                                |
| 15843 | SCA-1E 4-LINK UPPER MOUNT                  | 16285 | CA-1E COYOTE 2.1 WHEEL & TIRE SET 2PCS                            |
| 15844 | SCA-1E FRONT STEERING C HUB                | 16286 | SCA-1E MOTOR PINION GEAR 14T(48P)                                 |
| 15845 | SCA-1E FRONT STEERING KNUCKLE              | 16287 | SCA-1E 2.1 ATT TRANS HOUSING SET                                  |
| 15847 | SCA-1E F&R BUMPER HOLDER + F&R SHOCKS HOOP | 16289 | SCA-1E 2.1 ATT TRANS IDLER 13T                                    |
| 15848 | SCA-1E F&R SHOCKS & CHASSIS BRACE          | 16290 | SCA-1E 2.1 ATT TRANS CONVERSION SET                               |
| 15849 | SCA-1E F&R BUMPERS SET                     |       |   |
| 15850 | SCA-1E 4 SHACKLES AND BUMPER RISER         |       |   |
| 15851 | SCA-1E BODY POST & MOTOR GUARD             |       |   |
| 15852 | SCA-1E STEERING LINK                       |       |   |
| 15857 | SCA-1E BEARING & BUSHING SET               |       |   |
| 15860 | SCA-1E CENTER DIFFERENTIAL HOUSING SET     |       |   |
| 15861 | SCA-1E FRONT CVD SHAFT                     |       |   |
| 15862 | SCA-1E FRONT CVD DRIVE CUP                 |       |   |
| 15863 | SCA-1E FRONT CVD JOINT                     |       |   |
| 15864 | SCA-1E CENTER TOP SHAFT                    |       |   |
| 15865 | SCA-1E TOP SPUR GEAR 13T                   |       |   |

