

## Trail Start



Welcome to the world of Carisma SCA-1E Adventure. This is just the starting point on a journey that for many will undoubtedly last a lifetime. Where it eventually leads you to is your own choice. The first step was simply opening the box, the next will be entirely up to you.

Find that perfect location, drive from point A to point B, soaking in the scenery along the way and truly becoming one with your environment. The World is so diverse, it's terrain varied and challenging, but the SCA-1E offers the perfect Travelling Companion to embracing it all, head on...

The rig offers tried and trusted Off Road features like a Solid Axle, 4WD Driveline, a centrally located Transmission and Motor, True 4-Link Suspension, Adjustable Coil Over, Oil Filled Shocks, and Soft Compound, Thickly Treaded Scale Tyres. The electrics Splash proof, the Steering Servo High Torque and 2.4GHz Radio System, safe and Interference Free.

The bodyshell can be left completely stock or personalised to your own level of additional detail. You can alter the weight bias and how the rig physically drives by adjusting the main packs location, or adding Wheel Weights. Improve its extreme abilities by adding a Remote Winch to the front bumper and to aid Night Running, optional LED lights. The Electronic Speed Control is set into Crawler Mode as standard, offering instant reverse and an always on Drag Brakes. This improves the rigs ability to descend steep inclines under compete Electronic Descent Control.

Look at the SCA-1E as a blank sheet of paper. You decide its future feature set and abilities, and in turn it will help shape your own personal destiny. Thank you for becoming another member of the fast-growing Global Scale Community, and Carisma RC Family. We hope that you enjoy every aspect of the journey.

Life is short, so truly live it, one #CarismaScaleAdventure at a time!



### SAFETY PRECAUTIONS

Thank you for your purchase of the Carisma SCA-1E Rig. With proper use and regular, basic maintenance, this rig will provide you and all those who drive it hours of reliable RC fun! Please read this manual to fully understand its features, capabilities, and the best operation of the product. Should you have a technical question or need replacement parts, please contact your local Carisma RC dealer, original place of purchase or our dedicated web Shop: <http://www.carisma-shop.com>. You may also contact us direct via e-mail at: [webmaster@carisma-shop.com](mailto:webmaster@carisma-shop.com)

### WARNING

Read the **ENTIRE** instruction manual to become familiar with the features of this product before operating. This is a sophisticated hobby grade product. It must be operated with caution and common sense. It will require some basic mechanical ability. Failure to operate this product in a safe and responsible manner could result in injury or damage to the product, persons, or other property. This product is not intended for use by children without direct adult supervision. Do not use with incompatible components or alter this product in any way outside of the instructions provided by Carisma RC. This manual contains instructions for safe operation and maintenance. It is essential to read and follow all the instructions and warnings in the manual, prior to assembly, setup, or use. If you are not prepared to accept these condition, please return this product immediately to place of purchase.

### CAUTION:

This product is intended for ages 14+ Users under 18 years of age require parental supervision.  
 Do not expose any battery or component to open flame or other source of high temperature.  
 You must read the enclosed instruction manual completely prior to using this product.  
 Do not use any charger except the one included to charge the battery.  
 Never leave a battery unattended during charging.  
 Do not expose any components to moisture.  
 Always avoid water exposure to all equipment that's not specifically designed and protected for this purpose.  
 As the end user of this product, you are solely responsible for operating in a manner that does not endanger yourself and others, or result in damage to the product, or property of others.

Always carefully follow the directions and warnings for this, and any optional equipment (chargers, etc.).  
 This model is controlled by a radio signal subject to interference from many sources outside your control.  
 Never place any portion of the vehicle in your mouth as it could cause serious injury or even death.  
 Always operate your vehicle in open space away from full-size vehicles, traffic, people, and animals.  
 Always keep a safe distance in all directions around your model to avoid collisions or injury.  
 Always keep all chemicals, small parts, and anything electrical out of the reach of children.  
 Always keep transmitter powered on while your vehicle is power on.  
 Always remove batteries after use or before disassembly.  
 Never operate your vehicle with low transmitter batteries.  
 Always keep your vehicle in sight and under control.  
 Never operate your vehicle with damaged wiring.  
 Always let parts cool after use before touching.  
 Always keep moving parts clean and dry.  
 Always use fully charged batteries.



### WHAT'S IN THE BOX



SCA-1E Rig

Transmitter

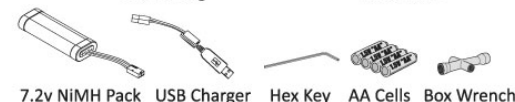

7.2v NiMH Pack

USB Charger

Hex Key

AA Cells

Box Wrench

### TOOLS RECOMMENDED (NOT INCLUDED)

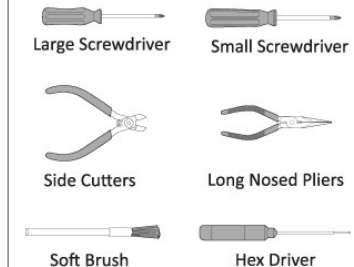

Large Screwdriver

Small Screwdriver

Side Cutters

Long Nosed Pliers

Soft Brush

Hex Driver

## ABOUT THE RADIO SYSTEM

### CTX-8000 2.4GHZ FHSS TECHNOLOGY SYSTEM

The following is an overview of the various functions and adjustments found on CTX-8000 radio system. It is important to read and understand these functions and adjustments before driving your Crawler.

#### TRANSMITTER FUNCTIONS:

**Steering Wheel:** Controls the turning direction of the Crawler (left/right).

**Throttle Trigger:** Controls the speed and direction of movement (forward/brake/reverse) of the Crawler.

**On/Off Switch:** Powers the transmitter on and off.

**FTN Key:** Used to synchronize the connection between the transmitter and receiver. May also serve as an additional function on different models.

**LED Indicator:** Glows green or red to indicate low battery power, synchronizing in progress, setting endpoints, and normal operation.

**ATV:** Adjust the maximum steering throw in both directions when turning the Crawler left of right.

**ST. Trim:** Adjusts the neutral (centered) position of the steering servo.

**TH. Trim:** Adjusts throttle neutral position.

**Steering Reverse:** Reverses the L/R direction when operating the steering wheel.

**Throttle Reverse:** Reverses the forward/reverse direction when operating throttle.

Usually, drivers will experience understeer when making a wide turn at high speed or oversteer when attempting sharp turns at high speed (easy to spin out). Drivers should practice a smooth application of both steering and throttle for various cornering speeds and road surfaces.

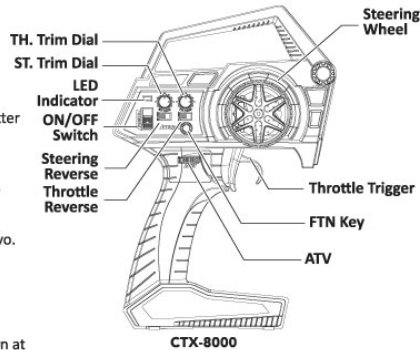

#### BATTERY INSTALLATION

1. Remove the battery compartment cover as shown.
2. Install the batteries observing the correct polarity as marked on the battery compartment.
3. Reinstall the battery compartment cover as pictured.

#### Warning:

Never disassemble alkaline batteries or place batteries in fire or near chemical agents, as personal injury or property damage can occur.

#### Battery Disposal:

- Observe local environmental regulations regarding disposal of expired batteries.
1. After use, dispose old batteries in designated areas far away from any water supply, household areas and plants.
  2. Submit the used batteries to specified battery recycling stations. Visit [www.call2recycle.org](http://www.call2recycle.org) for directions to battery recycling centers near you.

#### BATTERY LED INDICATOR

The Green LED indicator located on the front left side of the transmitter provides a visual status of battery condition. The green LED will illuminate solid, indicating that the batteries have sufficient power. When batteries voltage drops below 4 volts, LED will flash red, indicating the batteries are low and should be replaced.

- Solid GREEN :**  
Sufficient Power supply
- Flashing RED :**  
Time to replace batteries

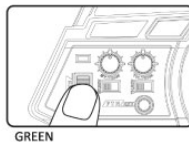

GREEN

#### ATV

ATV (adjustable travel volume) allows the driver to adjust the maximum steering angle in both directions. Experiment to find the ideal setting for your vehicle based on the running surface and personal preference.

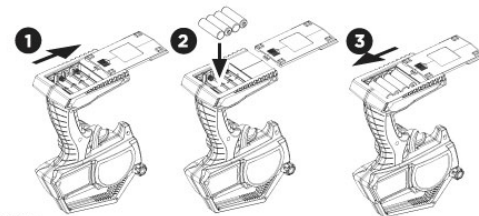

#### BEFORE DRIVING YOUR CRAWLER

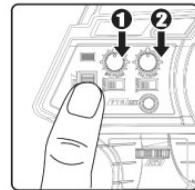

1. Steering: Adjust the steering trim so that the Crawler goes in a straight line without needing to touch the steering wheel.
2. Throttle: Adjust the throttle trim so that the vehicle remains at rest (not moving) when the throttle trigger is in the neutral position.

#### SERVO REVERSING

Use this feature to change the direction of steering wheel and throttle trigger.

**Steering Reverse:** Reverses the response direction when operating steering wheel. Right becomes left and vice versa.

**Throttle Reverse:** Reverses the response direction when operating throttle trigger. Pulling the throttle trigger becomes reverse and pushing the trigger is now forward.

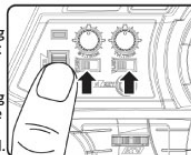

## SCA-1E Electrics

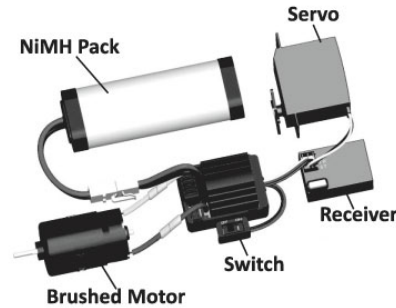

#### ESC/Transmitter Settings

The included RTR Tx and ESC will be set from the factory, but if you choose to change the radio please follow these instructions:

For LCD screen Tx's ensure that "D/R", "EPA" & "ALT" are set to 100%, and "TRIM" is set to 0 on Throttle Channel. For non-LCD screen Tx's, ensure that the throttle "TRIM" knob is set to neutral.

For Futaba and some OEM Tx's set the direction of the throttle channels reversing switch to "REV", while other radio systems should be set to "NOR"

Using the failsafe function of your chosen radio system is strongly advised to ensure the motor stops if signal is lost or Tx battery runs low.

**Warning: An incorrect Input Voltage Polarity will damage the ESC immediately.**

#### Throttle Calibration

In order to make the ESC match the throttle range of different transmitters, it needs to be calibrated. This is a simple three step procedure. First turn on the Tx. Then with the Tx's trigger in a neutral position the ESC. Wait for 3 seconds so the ESC can perform an Automatic Throttle Calibration. When this has finished and the ESC is ready to run, a long beep is emitted from the motor.

The Meaning of Beep Sound	LED Status
<ul style="list-style-type: none"> <li>• 1 short Beep: The battery is NiMH/NiCd</li> <li>• 2 short Beeps: The battery is 2S LIPO</li> <li>• 3 short Beeps: The battery is 3S LIPO</li> <li>• 1 long Beep: Self-test and throttle calibration is OK, the ESC is ready to run</li> </ul>	<ul style="list-style-type: none"> <li>• When the throttle stick is in neutral range, red LED is off</li> <li>• Forward, brake or reverse at partial throttle, red LED blinks</li> <li>• Forward, brake or reverse at full throttle, red LED is solid</li> </ul>

#### Throttle Trigger Position:

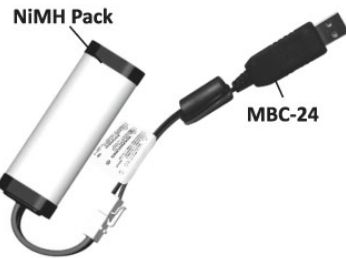
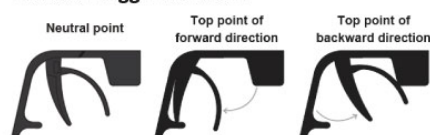

#### MBC-24 USB Charging

The SCA-1E comes supplied with a USB Trickle Charger. The MBC-24 is designed to charge a 7.2V NiMH battery ONLY. Note: DO NOT CHARGE ANY OTHER TYPE OF BATTERY. It is NOT intended for LiPo or Li-ion packs.

When connected to a standard USB power source, a red LED will light up indicating that the power is ON. The trickle output current is 100mA, and has a safe charging time for a fully drained battery to fully charged of about 14 hours. After charging, disconnect the USB charger, the battery should feel slightly warm. Part charged packs will peak much faster, so if the battery becomes warm early on in charge cycle, please disconnect the USB Charger and run until fully discharged. It is always best to fully discharge and cycle NiMH packs. It may take a few cycles for your pack to reach its full potential.

**Note: Always charge the battery under supervision and do not leave the charging battery unattended. The red LED will NOT turn off, it only indicates power is present to charge.**

#### WP-1040 Brushed Crawler ESC

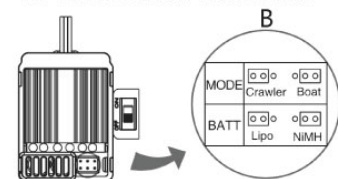

The ESC will come set as standard from the factory in "Crawler Mode" and for the "NiMH" battery type. It is programmed by the use of jumpers, so tweezers are recommended to plug and unplug each one to change parameters.

Remember to change to LIPO mode when using this type of pack, as the ESC has a built in Low Voltage detection circuit to safeguard the LiPo from over-discharging and possible permanent damage.



### FCC Information

This equipment has been tested and found to comply with the limits for a Class B digital device, pursuant to part 15 of the FCC Rules. These limits are designed to provide residential protection against harmful interference in a residential installation. This equipment generates, uses, and can radiate radio frequency energy and, if not installed and used in accordance with the instructions, may cause harmful interference to radio communications. However, there is no guarantee that interference will not occur in a particular installation. If this equipment does cause harmful interference to radio or television reception, which can be determined by turning the equipment on and off, the user is encouraged to correct the interference by one or more of the following measures: Reorient or relocate the receiving antenna. Increase the separation between the equipment and the receiver. Connect the equipment into an outlet on a circuit different from that to which the receiver is connected.

### FCC Warning:

The equipment may generate or use radio frequency energy. Changes or modifications to this equipment may cause harmful interference unless the modifications are expressly approved in the instruction manual. Modifications not authorized by the manufacturer may void the user's authority to operate this device. This device complies with part 15 of the FCC Rules. Operation is subject to the following two conditions (1) This device may not cause harmful interference, and (2) this device must accept any interference received, including interference that may cause undesired operation.

### Limited Warranty

**Warranty Period:** Carisma R/C warrants that the **SC-1E** ("Product") will be free from original factory defects in materials and workmanship upon purchase ("Warranty Period"). **What is Not Covered** - This warranty is not transferable and does not cover (a) cosmetic damage, (b) damage due to acts of God, accident, misuse, abuse, negligence, commercial use, or due to improper use, installation, operation or maintenance, (c) modification to any part of the Product, (d) attempted service by anyone other than a Carisma R/C authorized service center, or (e) Product not purchased from an authorized Carisma RC dealer.

**OTHER THAN THE EXPRESS WARRANTY ABOVE, CARISMA RC MAKES NO OTHER WARRANTY OR REPRESENTATION, AND THEREFORE DISCLAIMS ANY AND ALL IMPLIED WARRANTIES, INCLUDING, WITHOUT LIMITATION, THE IMPLIED WARRANTIES OF NON-INFRINGEMENT, MERCHANTABILITY AND SUITABILITY FOR A PARTICULAR PURPOSE. THE PURCHASER ACKNOWLEDGES THAT THEY ALONE HAVE DETERMINED THAT THE PRODUCT WILL MEET THE REQUIREMENTS OF THEIR INTENDED USE.**

**Purchaser's Remedy** - Carisma RC's sole obligation and purchaser's sole and exclusive remedy shall be that Carisma RC will, at its option, either (a) service, or (b) replace, any Product determined by Carisma RC to be defective. Carisma RC reserves the right to inspect any and all Product(s) involved in a warranty claim. Service or replacement decisions are at the sole discretion of Carisma RC. Proof of purchase is required for all warranty claims. **SERVICE OR REPLACEMENT AS PROVIDED UNDER THIS WARRANTY IS THE PURCHASER'S SOLE AND EXCLUSIVE REMEDY.**

### Limitation of Liability

**CARISMA RC SHALL NOT BE LIABLE FOR SPECIAL, INDIRECT, INCIDENTAL OR CONSEQUENTIAL DAMAGES, LOSS OF PROFITS OR PRODUCTION OR COMMERCIAL LOSS IN ANY WAY, REGARDLESS OF WHETHER SUCH CLAIM IS BASED IN CONTRACT, WARRANTY, TORT, NEGLIGENCE, STRICT LIABILITY OR ANY OTHER THEORY OF LIABILITY, EVEN IF CARISMA RC HAS BEEN ADVISED OF THE POSSIBILITY OF SUCH DAMAGES.**

Further, in no event shall the liability of Carisma RC exceed the individual price of the Product on which liability is asserted. As Carisma RC has no control over use, setup, final assembly, modification or misuse, no liability shall be assumed nor accepted for any resulting damage or injury. By the act of use, setup or assembly, the user accepts all resulting liability. If you see the purchaser or user are not prepared to accept the liability associated with the use of the Product, purchaser is advised to return the Product immediately in new and unused condition to the place of purchase. This warranty gives you specific legal rights, and you may also have other rights which vary from country to country, or state to state. Carisma RC reserves the right to change or modify this warranty at any time without notice.

Carisma LTD  
21/ Floor, Kingsway Industrial Building,  
Phase 2, 173 - 175 Wo Yi Hop Road,  
Kwai Chung, N.T., Hong Kong.

**Note:** For official Carisma RC spare parts, see your local hobby shop or place of purchase first. If unavailable, parts can be ordered direct at: <http://www.carisma-shop.com>

## SCA-1E Setup Notes



**Shocks, Oil Weight & Springs:**

**Weight Bias:**

**Motor Pinion & Spur Gear:**

**Slipper Clutch & Motor Wind:**

**Other Setup Options Used:**

**"Owning a Coyote is just the start, where it takes you is the real adventure..."**

Ivan Carisma



**Rear Axle In Stock RTR Format**

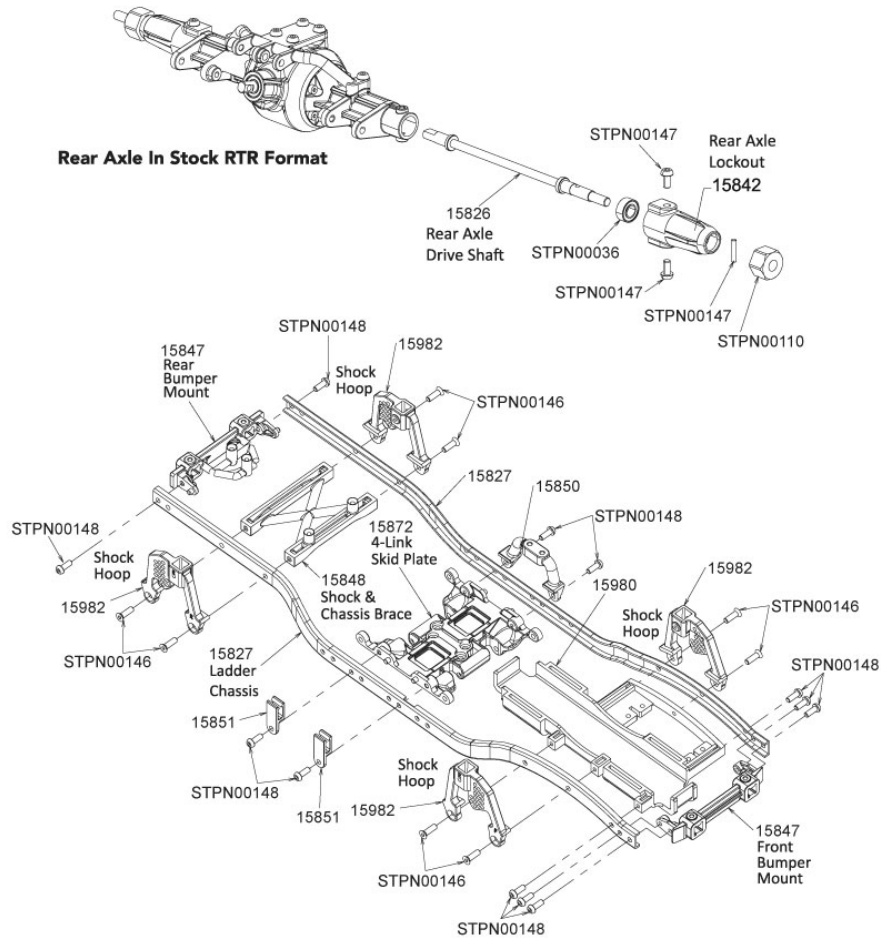

**PART DESCRIPTION**

- 15826 Rear Axle Drive Shaft
- 15827 SCA-1E Ladder Chassis
- 15841 F & R Axle Casing Half
- 15842 Rear Axle Lockout
- 15847 F & R Bumper Mount + F&R Shock Hoop
- 15848 F & R Shock & Chassis Brace

- 15850 Center Differential Mount
- 15851 Body Posts & Motor Guard
- 15852 Steering Link
- 15872 4-Link Skid Plate
- 15980 ????
- 15982 ????

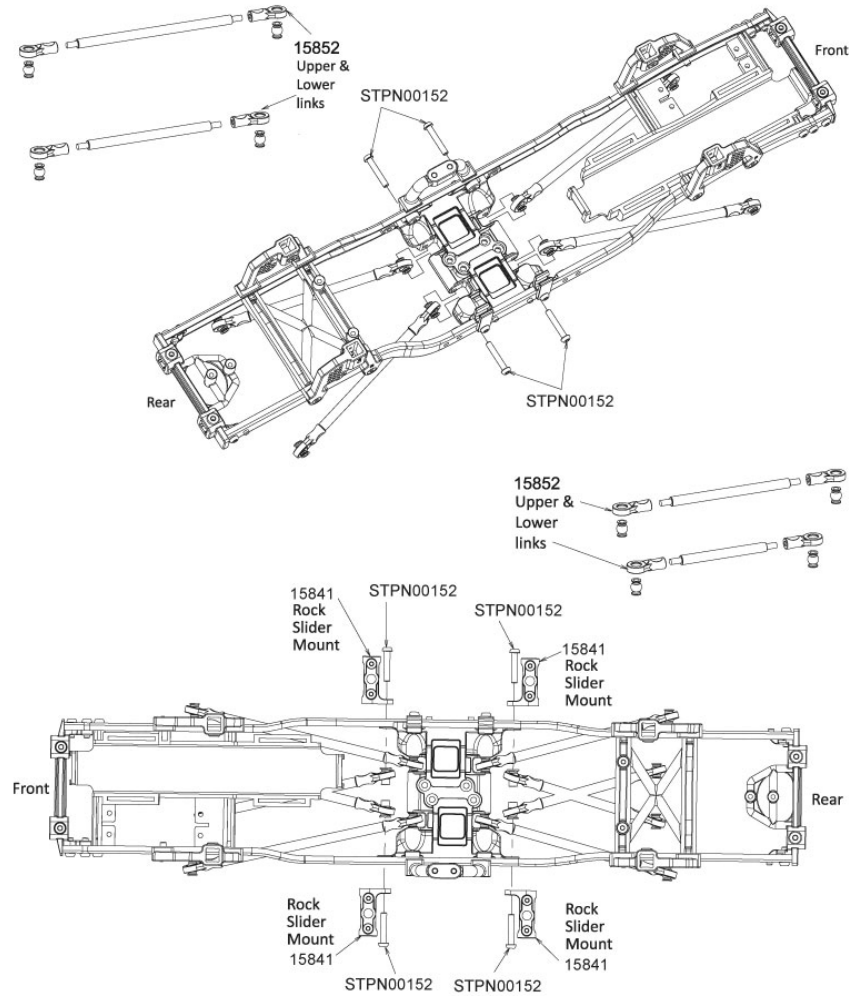

### SCA-1E Shocks

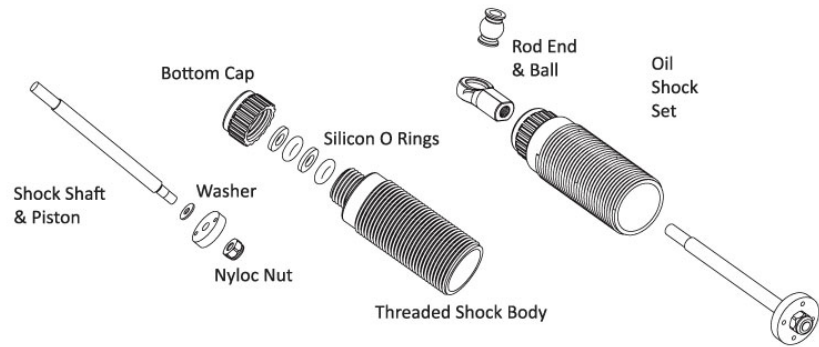

**Note:** Shock oil and spring choice affects the driving characteristics of your rig. The thicker the oil is, the slower the shock piston moves inside the shock body and the slower the rig can react to differences in your chosen running surface. Too thin and the rig can become unpredictable when crawling and suffer from excessive Torque Twist. This is a phenomenon where the torque of the driveline is transferred through the axles and shocks on one or more corners of the rig compress to compensate. All solid axle rigs suffer from this to some extent, but with the right oil, springs and pre-load applied to the shock/shocks that compress, this can be vastly improved.

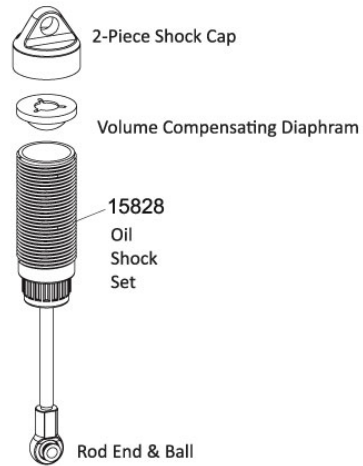

**SCA-1E Stock Shock Specs:**  
**Springs: Soft from Medium**  
**Oil: Front = 35W Rear = 35W**

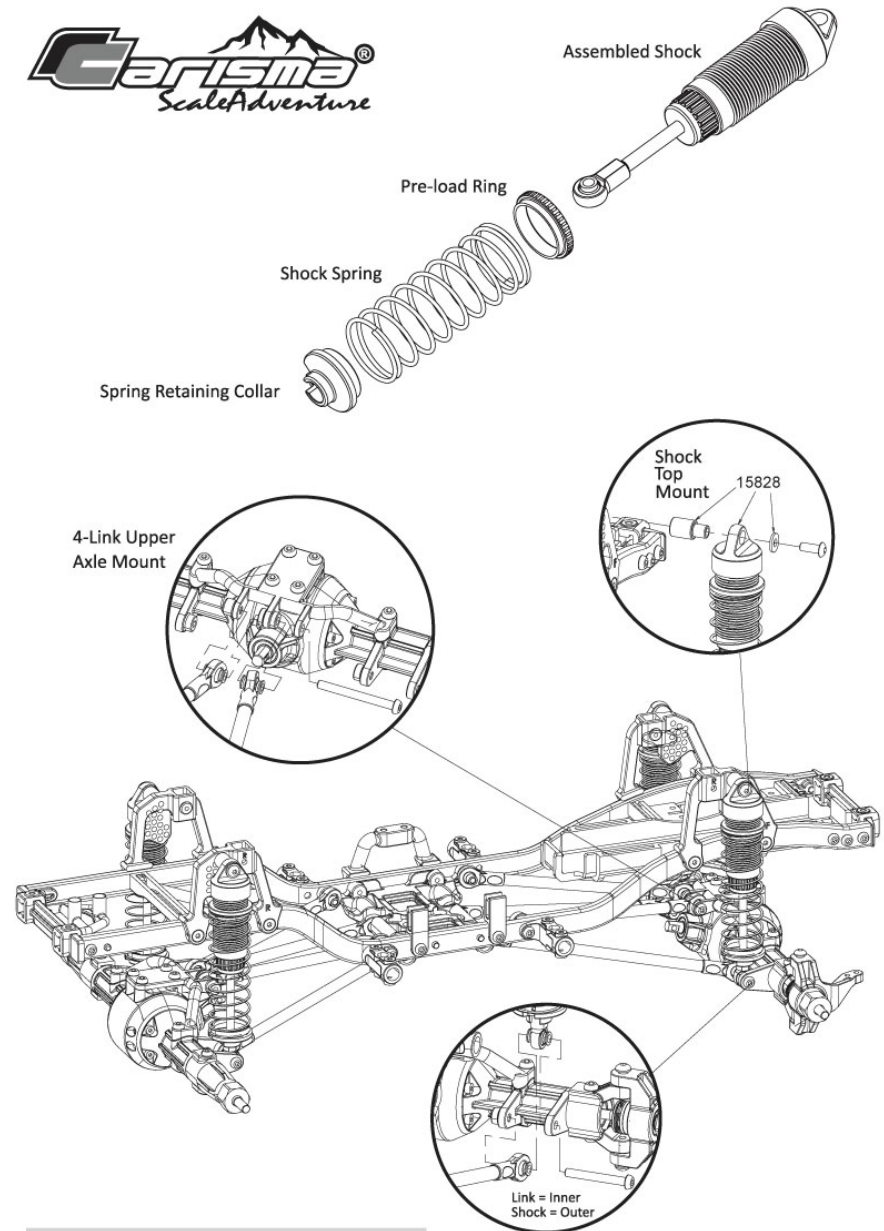

#### PART DESCRIPTION

15828 Oil Shocks Set

**Note:** Uper & lower links are “Double Triangulated” for a more stable chassis geometry & reduction in “Axle Steer”

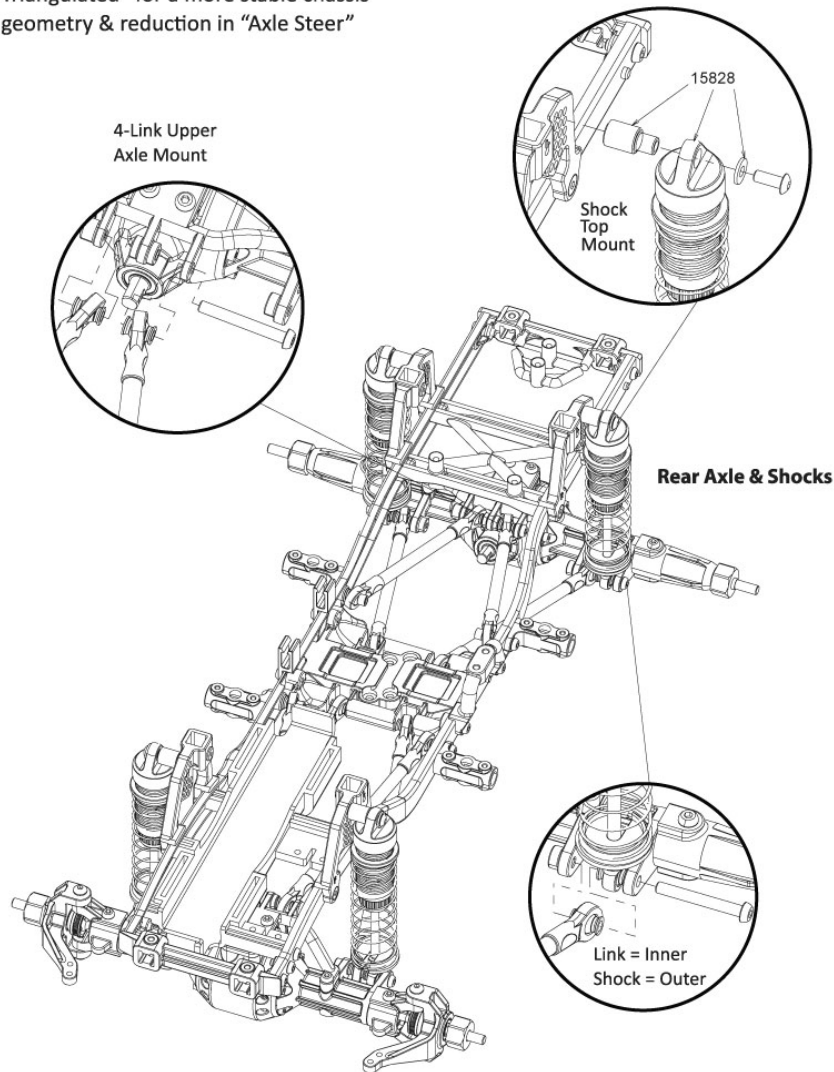

**Note:** Axle Steer is when an axle (front or rear) moves in a front to back arc as it articulates, making the rig crab. The end result being innacurate & unpredictable handling.

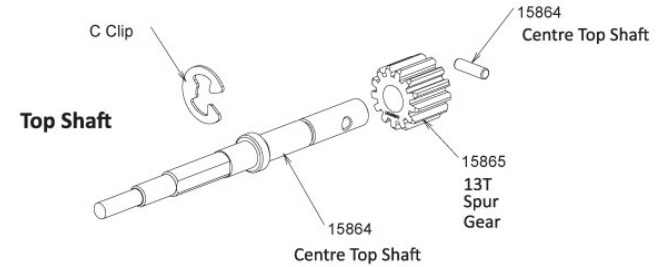

**Note:** With the stock 17T Pinion and 83T Spur gear the final drive ratio of the transmission is 15:1. This means that for every fifteen turns of the Motor, the Transmissions outdrives turn just once. This offers the locked axles (and in turn the wheels and tyres) a lower wheel speed and lots of crawling Torque.

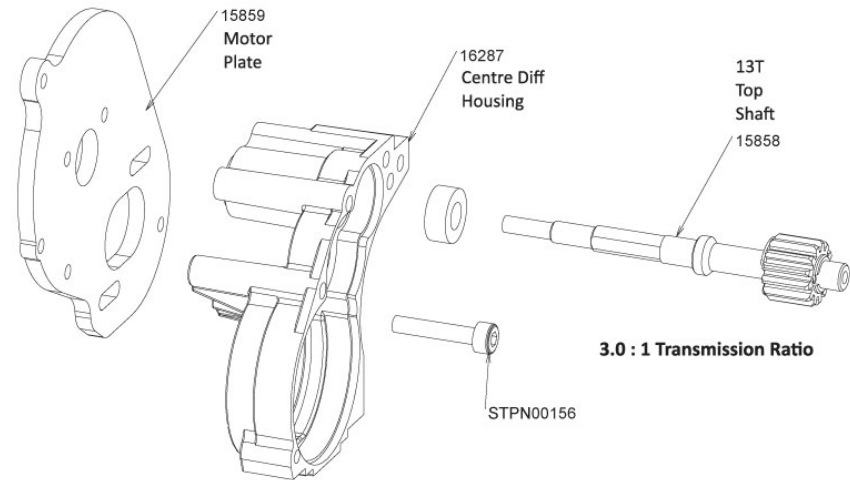

**PART DESCRIPTION**

15828 Oil Shocks Set

15858 Center Top Shaft assembly (13T)

15859 Motor Plate

15864 Center Top Shaft

15865 Top Spur Gear 13T

16287 ?????

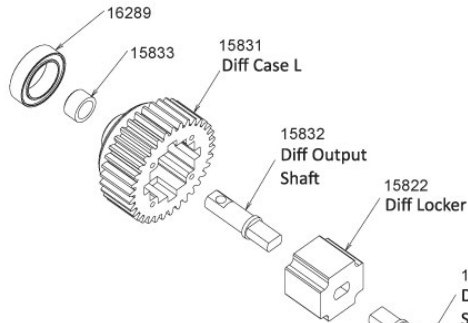

**Middle Locked Diff Assembly**

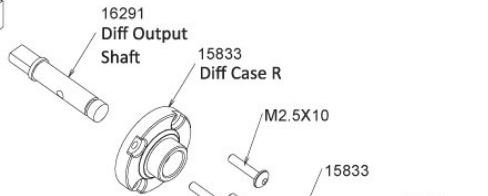

**SCA-1E Transmission**

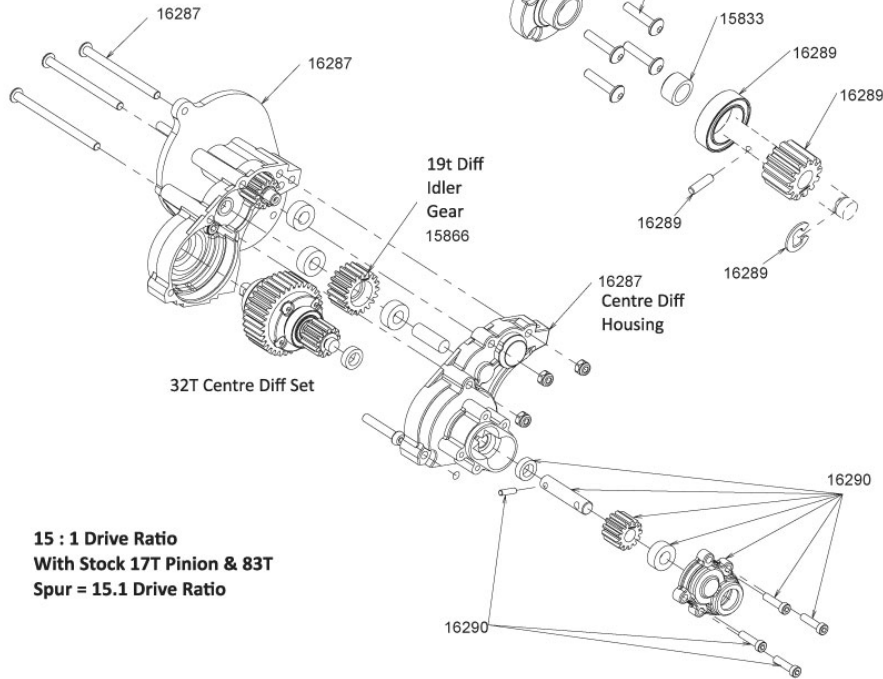

**15 : 1 Drive Ratio  
With Stock 17T Pinion & 83T  
Spur = 15.1 Drive Ratio**

**PART DESCRIPTION**

- 15831 Center Differential Case - L
- 15832 Center Differential output Shaft
- 15833 Center Differential Case - R
- 15866 Differential Idler Gear 19T
- 15867 Slipper Hardware Set

- 15868 Slipper Plate Set
- 15869 Slipper Pads
- 15870 Spur Gear 83T
- 16276 ?????
- 16286 ?????
- 16287 ?????

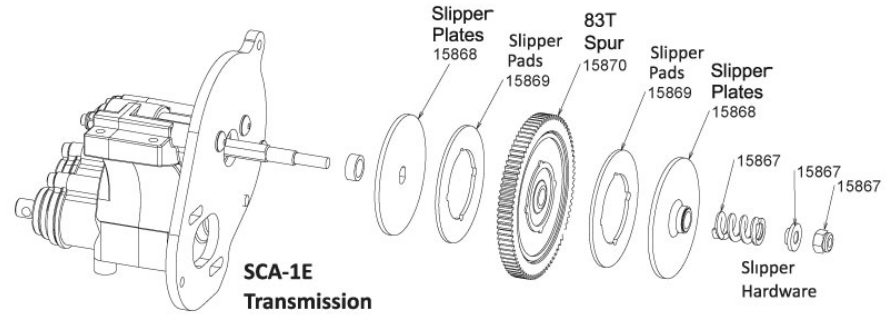

**SCA-1E  
Transmission**

**Note:** Setting the Pinion and Spur Gear Mesh, and the Slipper Clutch correctly are very important for smooth running and to protect the driveline from damage.

**Gear Mesh:** Use a thin strip of printer or note paper, and feed this between the Motors Pinion and the Spur. Press together, then tighten up motor bolts. Once paper is then pulled clear, will set the perfect gear mesh.

**Slipper Clutch:** Place the rig on a high grip surface, such as a carpet. The slippers spring should then be compressed all the way in using the M3 Nyloc nut, then backed off approximately 1.5 turns. The slipper should only slip in the event the driveline gets locked up under full load when Crawling.

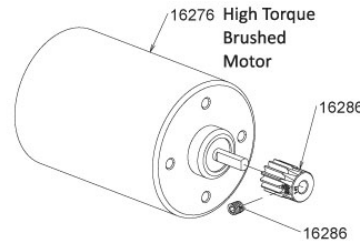

**SCA-1E Motor &  
Transmission**

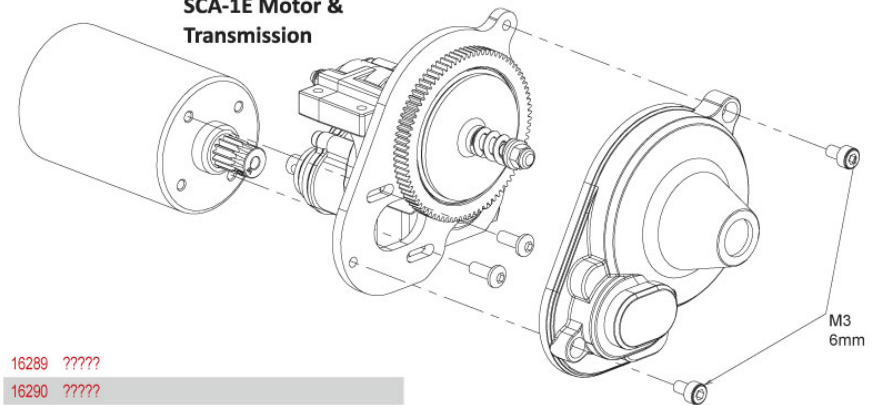

- 16289 ?????
- 16290 ?????
- 16291 ?????



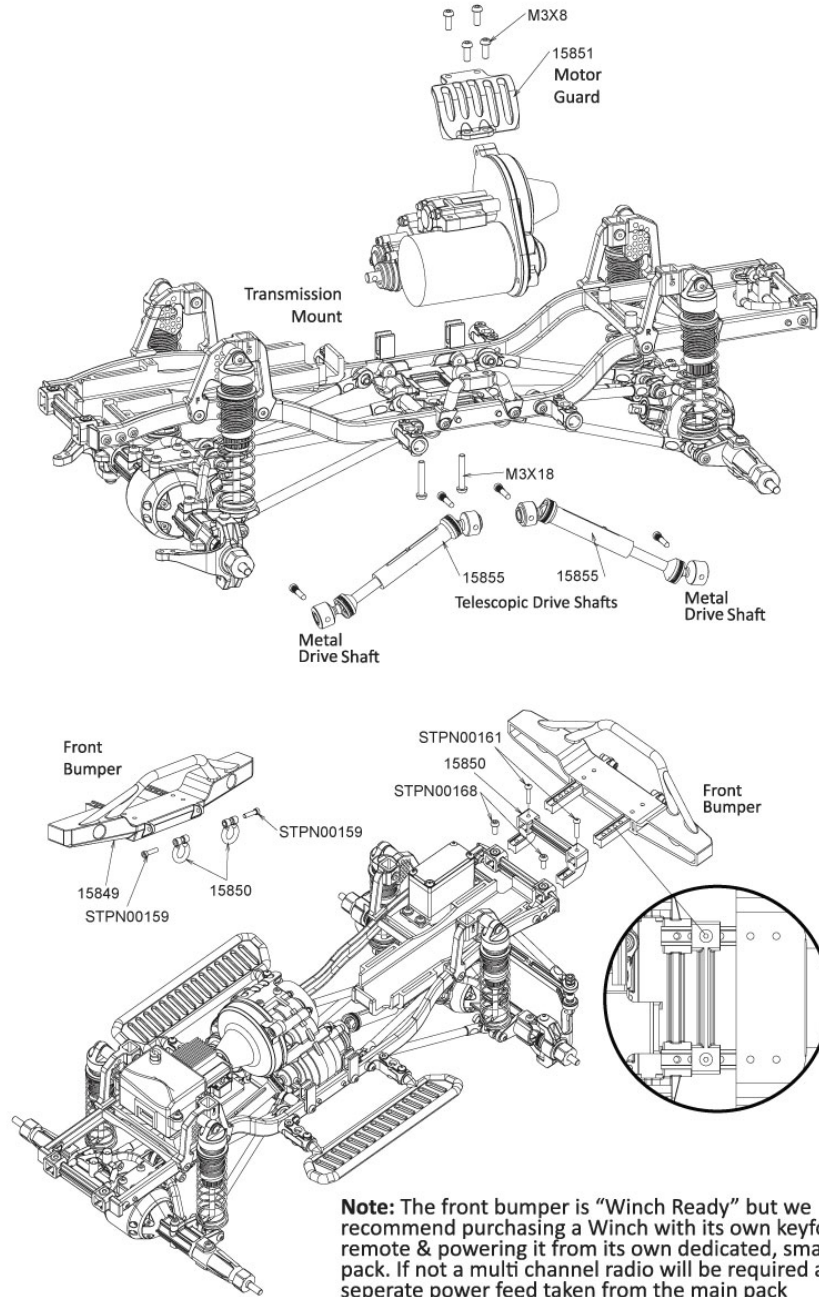

**Note:** The front bumper is "Winch Ready" but we recommend purchasing a Winch with its own keyfob remote & powering it from its own dedicated, smaller pack. If not a multi channel radio will be required and separate power feed taken from the main pack

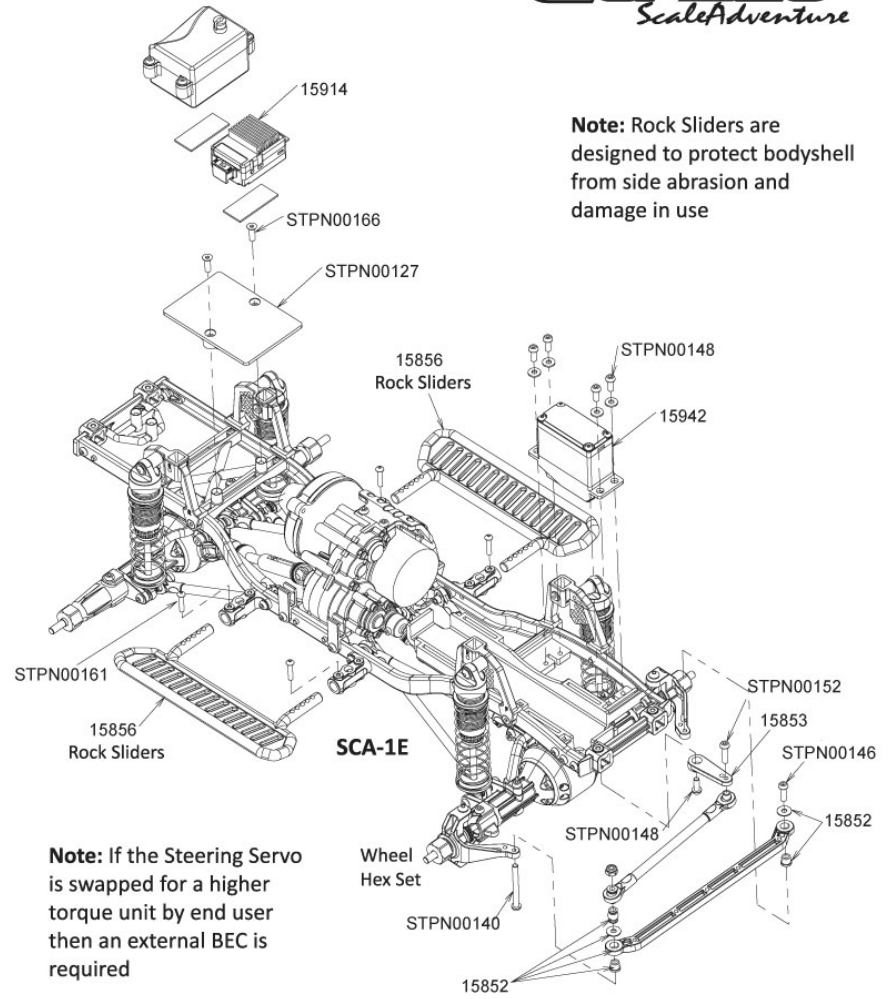

**Note:** Rock Sliders are designed to protect bodyshell from side abrasion and damage in use

**Note:** If the Steering Servo is swapped for a higher torque unit by end user then an external BEC is required

**PART DESCRIPTION**

- 15849 F & R Bumpers Set
- 15850 Center Differential Mount
- 15852 Steering Link
- 15853 Drag Link and Servo Horn

- 15854 Wheel Hex Set
- 15855 Drive Shafts
- 15856 Rock Sliders
- 15914 ?????
- 15942 ?????

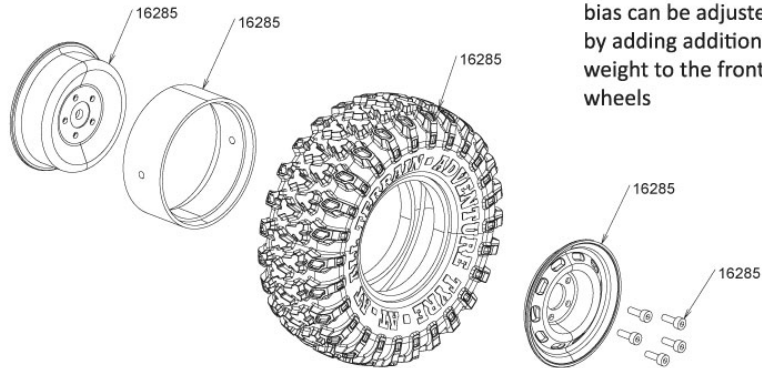
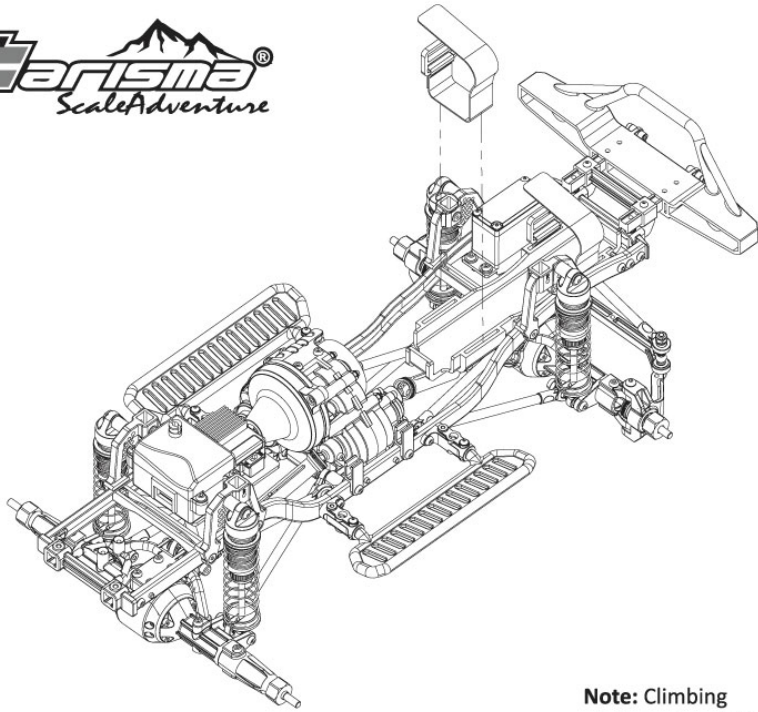

**Note:** Climbing ability and weight bias can be adjusted by adding additional weight to the front wheels

**PART DESCRIPTION**

15851 Body Posts & Motor Guard

15854 Wheel Hex Set

16285 ??????

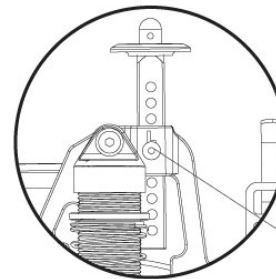
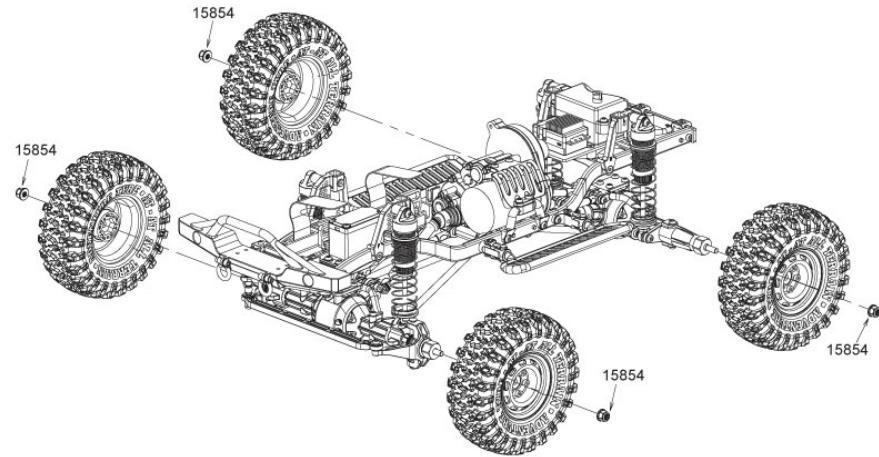

**15851 Body Posts & Motor Guard**

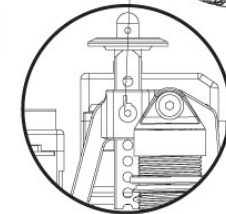
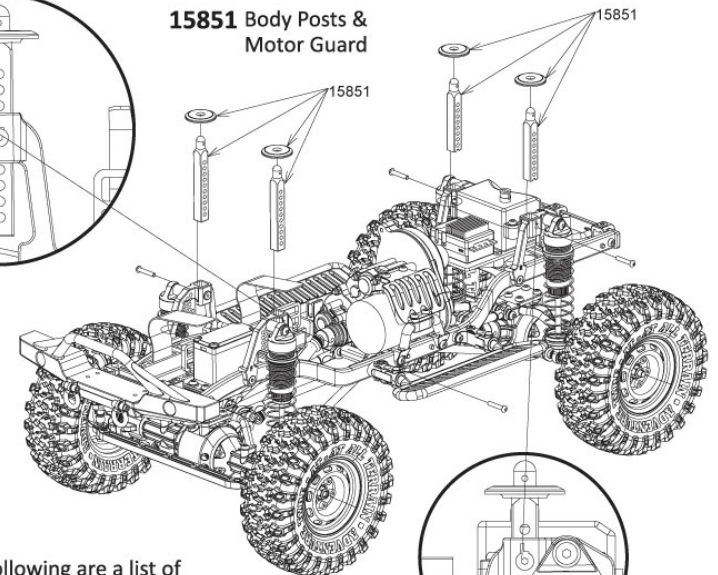

**Note:** The following are a list of official SCA-1E Option Parts designed to add additional strength and durability to different key areas of the rig

